

Radial loading: Spring in tension (Ft)

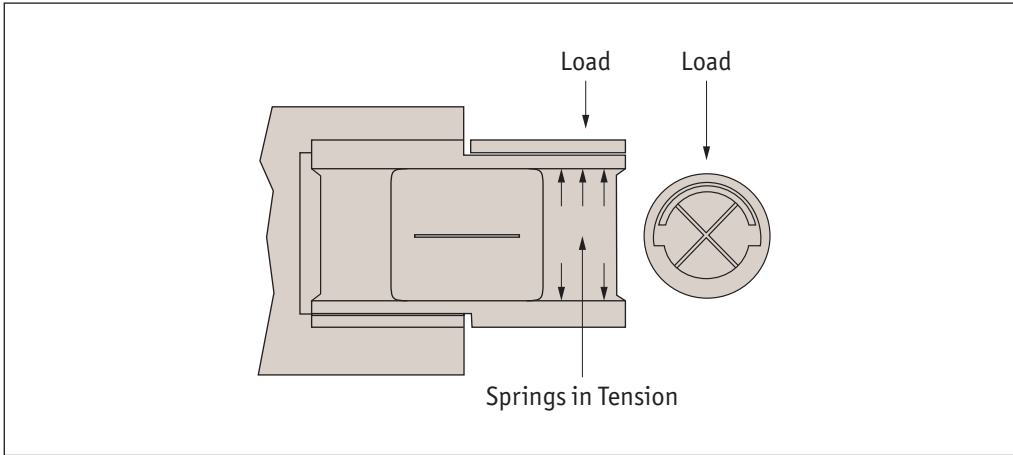

Radial loading: Spring in compression (Fc)

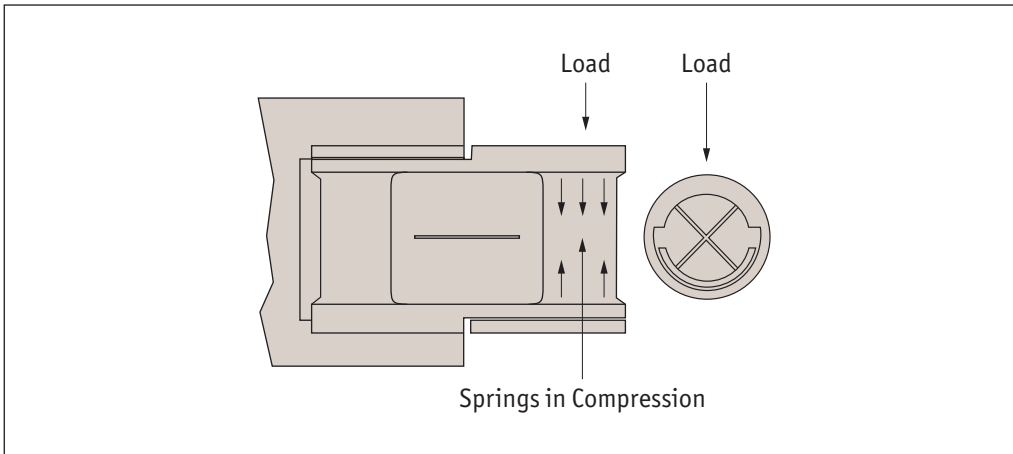

Axial loading: Springs in shear

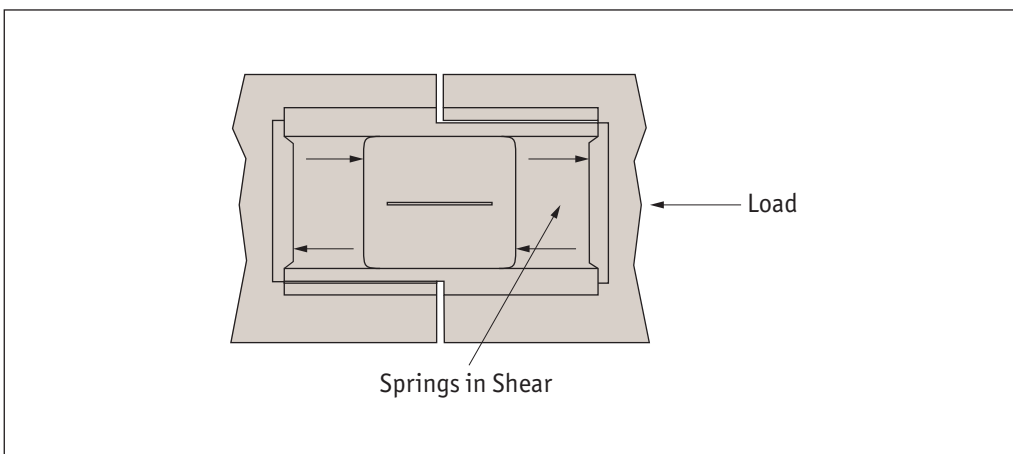



R4000

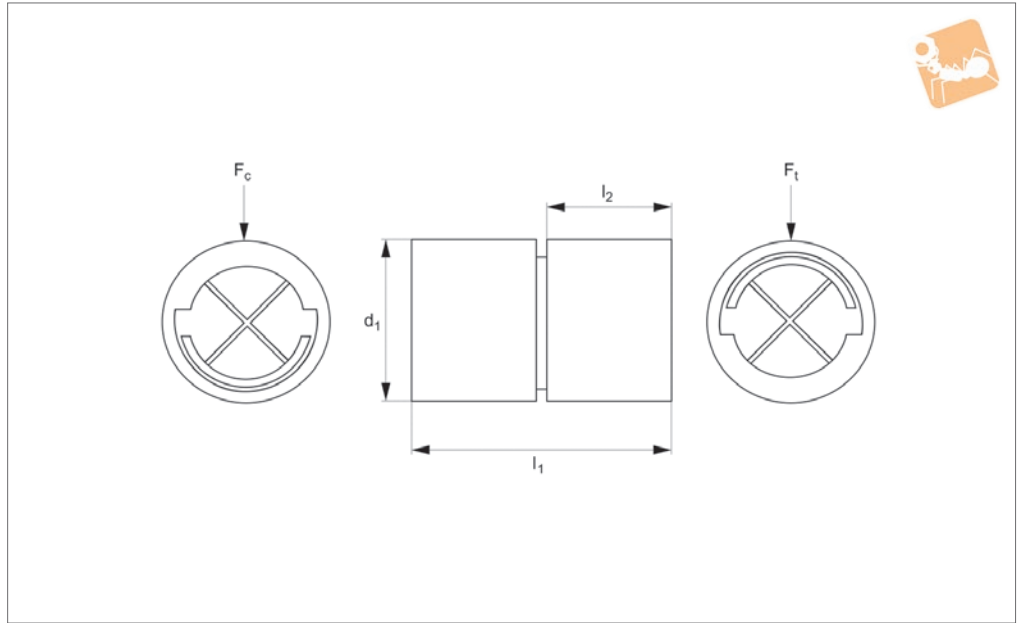

Material

Body stainless steel (416), spring and core: 410 and 420 stainless steel (46-56

HRC), braze alloy AMS 4765.

-35°C to + 190°C.

Technical Notes

Operating temperature

Order No.	d_1 +0.00 -0.13	l_1 ±0.08	l_2 min.	Torsional spring rate Nmm/°	Load f_c compression kg max.	Load f_t tension kg max.	Angular movement max.
R4000.A-10	3,175 (1/8")	5.08	2.24	0.034	0.43	1.72	±15°
R4000.A-20	3,175 (1/8")	5.08	2.24	0.20	4.03	5.76	±7,5°
R4000.A-30	3,175 (1/8")	5.08	2.24	1.67	11.47	11.47	±3,7°
R4000.B-10	3,969 (5/32")	6.35	2.90	0.045	0.64	2.54	±15°
R4000.B-20	3,969 (5/32")	6.35	2.90	0.42	6.21	8.89	±7,5°
R4000.B-30	3,969 (5/32")	6.35	2.90	3.35	17.82	17.82	±3,7°
R4000.C-10	4,763 (3/16")	7.62	3.45	0.08	0.90	3.53	±15°
R4000.C-20	4,763 (3/16")	7.62	3.45	0.68	8.84	12.65	±7,5°
R4000.C-30	4,763 (3/16")	7.62	3.45	5.45	25.31	25.31	±3,7°
R4000.D-10	6,350 (1/4")	10.16	4.67	0.20	1.63	6.44	±15°
R4000.D-20	6,350 (1/4")	10.16	4.67	1.67	15.87	22.68	±7,5°
R4000.D-30	6,350 (1/4")	10.16	4.67	13.39	45.36	45.36	±3,7°
R4000.E-10	7,938 (5/16")	12.70	5.89	0.42	2.58	10.34	±15°
R4000.E-20	7,938 (5/16")	12.70	5.89	3.35	24.95	35.65	±7,5°
R4000.E-30	7,938 (3/10")	12.70	5.89	26.75	71.26	71.26	±3,7°
R4000.F-10	9,525 (3/8")	15.24	7.09	0.73	3.81	15.24	±15°
R4000.F-20	9,525 (3/8")	15.24	7.09	5.45	35.88	51.25	±7,5°
R4000.F-30	9,525 (3/8")	15.24	7.09	45.22	102.51	102.51	±3,7°
R4000.G-10	12,700 (1/2")	20.32	9.50	1.67	6.53	26.03	±15°
R4000.G-20	12,700 (1/2")	20.32	9.50	13.39	63.50	90.72	±7,5°
R4000.G-30	12,700 (1/2")	20.32	9.50	107.19	181.44	181.44	±3,7°
R4000.H-10	15,875 (5/8")	25.40	11.91	3.33	10.43	41.73	±15°
R4000.H-20	15,875 (5/8")	25.40	11.91	26.75	100.29	143.25	±7,5°
R4000.H-30	15,875 (5/8")	25.40	11.91	214.02	286.45	286.45	±3,7°
R4000.I-10	19,050 (3/4")	30.48	14.32	5.45	14.69	58.69	±15°
R4000.I-20	19,050 (3/4")	30.48	14.32	45.22	143.88	205.52	±7,5°
R4000.I-30	19,050 (3/4")	30.48	14.32	368.49	411.00	411.00	±3,7°
R4000.J-10	25,400 (1")	40.64	19.40	13.39	26.85	107.32	±15°
R4000.J-20	25,400 (1")	40.64	19.40	107.19	256.87	366.92	±7,5°
R4000.J-30	25,400 (1")	40.64	19.40	881.66	733.00	733.00	±3,7°



Flexure Pivot Bearings

double-ended

Flexure Pivot Bearings



R4002

FLEXURE PIVOT BEARINGS

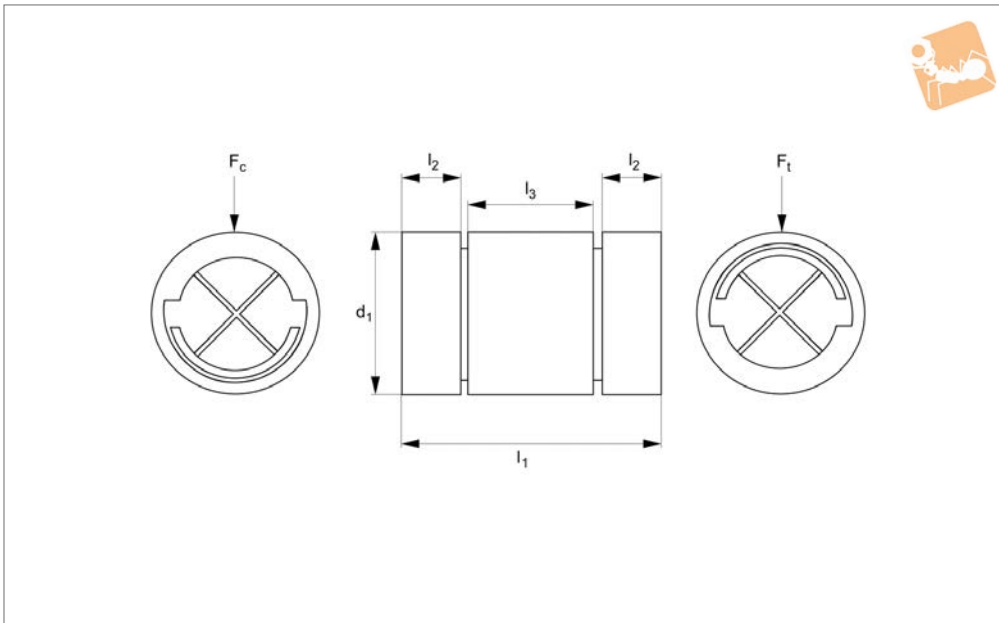

Material

Body stainless steel (416), spring and core: 410 and 420 stainless steel (46-56

HRC), braze alloy AMS 4765.

-35°C to + 190°C.

Technical Notes

Operating temperature

Order No.	d ₁ +0 -0.013	l ₁ ±0.08	l ₂ min.	l ₃ min.	Torsional spring rate Nmm/°	Load f _c compression kg max.	Load f _t tension kg max.	Angular movement max.
R4002.AD-10	3,175 (1/8")	5.08	0.97	1.78	0.034	0.43	1.72	±15°
R4002.AD-20	3,175 (1/8")	5.08	0.97	1.78	0.20	4.03	5.76	±7,5°
R4002.AD-30	3,175 (1/8")	5.08	0.97	1.78	1.67	11.47	11.47	±3,7°
R4002.BD-10	3,967 (5/32")	6.35	1.27	2.54	0.045	0.64	2.54	±15°
R4002.BD-20	3,967 (5/32")	6.35	1.27	2.54	0.42	6.21	8.89	±7,5°
R4002.BD-30	3,967 (5/32")	6.35	1.27	2.54	3.35	17.82	17.82	±3,7°
R4002.CD-10	4,763 (3/16")	7.62	1.52	3.05	0.08	0.90	3.53	±15°
R4002.CD-20	4,763 (3/16")	7.62	1.52	3.05	0.67	8.84	12.65	±7,5°
R4002.CD-30	4,763 (3/16")	7.62	1.52	3.05	5.45	25.31	25.31	±3,7°
R4002.DD-10	6,350 (1/4")	10.16	2.11	4.19	0.20	1.63	6.44	±15°
R4002.DD-20	6,350 (1/4")	10.16	2.11	4.19	1.67	15.87	22.68	±7,5°
R4002.DD-30	6,350 (1/4")	10.16	2.11	4.19	13.39	45.36	45.36	±3,7°
R4002.ED-10	7,938 (5/16")	12.70	2.67	5.23	0.42	2.58	10.34	±15°
R4002.ED-20	7,938 (5/16")	12.70	2.67	5.23	3.345	24.95	35.65	±7,5°
R4002.ED-30	7,938 (5/16")	12.70	2.67	5.23	26.75	71.26	71.26	±3,7°
R4002.FD-10	9,525 (3/8")	15.24	3.25	6.48	0.73	3.81	15.24	±15°
R4002.FD-20	9,525 (3/8")	15.24	3.25	6.48	5.446	35.88	51.25	±7,5°
R4002.FD-30	9,525 (3/8")	15.24	3.25	6.48	45.22	102.51	102.51	±3,7°
R4002.GD-10	12,700 (1/2")	20.32	4.39	8.76	1.67	6.53	26.03	±15°
R4002.GD-20	12,700 (1/2")	20.32	4.39	8.76	13.39	63.50	90.72	±7,5°
R4002.GD-30	12,700 (1/2")	20.32	4.39	8.76	107.19	181.44	181.44	±3,7°
R4002.HD-10	15,875 (5/8")	25.40	5.33	10.92	3.345	10.43	41.73	±15°
R4002.HD-20	15,875 (5/8")	25.40	5.33	10.92	26.75	100.29	143.25	±7,5°
R4002.HD-30	15,875	25.40	5.33	10.92	214.0	286.45	286.45	±3,7°
R4002.ID-10	19,050 (3/4")	30.48	6.68	13.21	5.44	14.69	58.69	±15°
R4002.ID-20	19,050 (3/4")	30.48	6.68	13.21	45.22	143.88	205.52	±7,5°
R4002.ID-30	19,050 (3/4")	30.48	6.68	13.21	368.49	411.00	411.00	±3,7°
R4002.JD-10	25,400 (1")	40.64	9.22	18.29	13.39	26.85	107.32	±15°
R4002.JD-20	25,400 (1")	40.64	9.22	18.29	107.19	256.87	366.92	±7,5°
R4002.JD-30	25,400 (1")	40.64	9.22	18.29	881.65	733.00	733.00	±3,7°

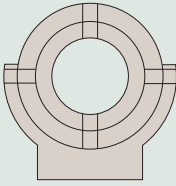
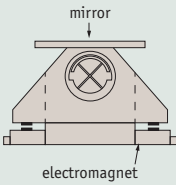
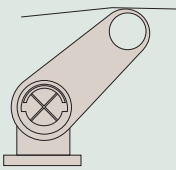
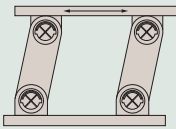
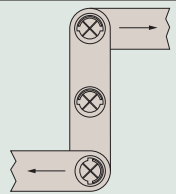
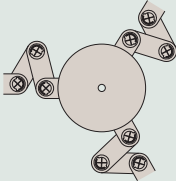
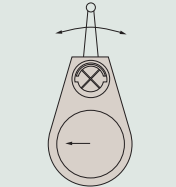
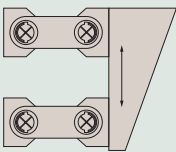
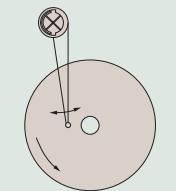

Flexure Pivot Bearings from Automation Components

	Application	Notes
	Gimbals	Free from backlash, friction and wear. Flexure bearings give the extreme accuracy needed for positioning precision optics.
	Oscillating mirrors	Optical scanners using flexure bearings provide for the ultimate in cost-effective design. They allow for easy assembly and, with indefinite life expectancies, perform with undiminished accuracy.
	Tensioners	Belt or chain tensioning can be easily achieved through the use of flexure bearings. Tolerant of hostile environments and not subject to wear, extreme long life can be expected without maintenance.
	Linear positioners	Free of errors due to backlash, friction or wear, flexure bearings mounted in suitable geometric structures can provide accurate linear movement or adjustment.
	Lever actuators	Accurate motion requirements in areas of contamination, temperature extremes, or in a vacuum, can be easily provided through linkages utilising flexure bearings. Used in dynamic conditions, the precision of load sensitive systems can be increased to a much higher level than with ball bearings.
	Restrained or damped oscillating motion	Eccentric or circular oscillating mechanisms can utilise Flexure bearings to provide centre and dampening actions for a lifetime of maintenance free performance.
	Gauges sensors	Miniature sizes which are free of error from backlash, friction or wear, make flexure bearings ideal for applications where position must be accurately measured or outside forces sensed.
	Vibrating/sorting mechanisms	A workhorse, capable of supporting heavy loads for years of continuous service without wear or deterioration, Flexure bearings are ideal for equipment such as vibrating hoppers operating in severe environments.
	Optical or magnetic disc read/write heads	With their constant predictable spring rate, Flexure bearings are immune to the problems of starting vs. moving torque requirements of conventional bearings. Also since they operate without backlash errors or wear, a lifetime of accurate performance can be expected.

The following examples are a few of the possible methods for installing standard flexure bearings. Other techniques may provide satisfactory results. Special options, such as flanged or drilled and tapped sleeves may be provided upon request. Please contact our Technical Department with any questions or for a review of mounting requirements.

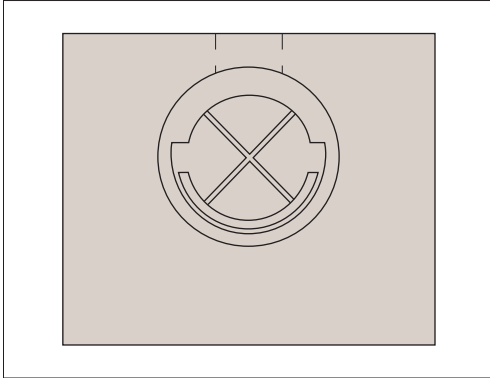

Set screw

One or more properly sized cup point set screws may be used to clamp the bearing in place. Hole size should be 0.0005" to 0.0010" larger than the bearing.

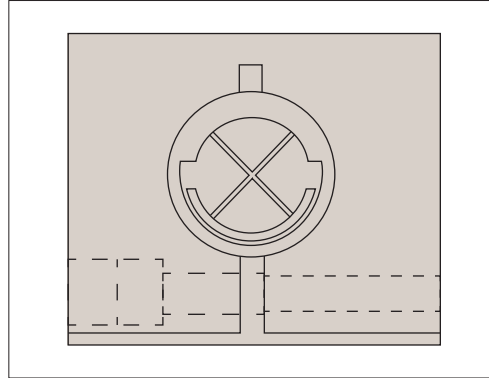

Clamp screw

A clamping screw applies suitable pressure to retain the bearing in place. Hole size should be 0.0005" to 0.0010" larger than the bearing.

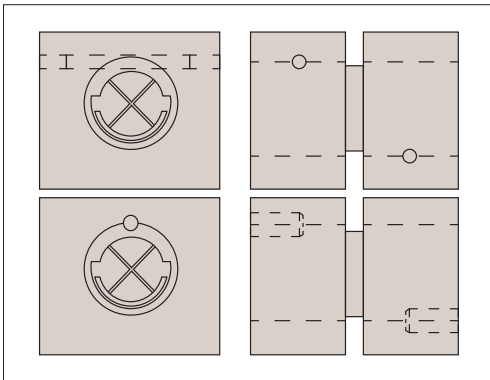

Radial or axial pins

Pins may be pressed into holes drilled through the mounting bracket and the bearing sleeve. Care must be exercised to orientate the bearing properly so the springs are not damaged. Hole size should be 0.0005" to 0.0010" larger than the bearing.

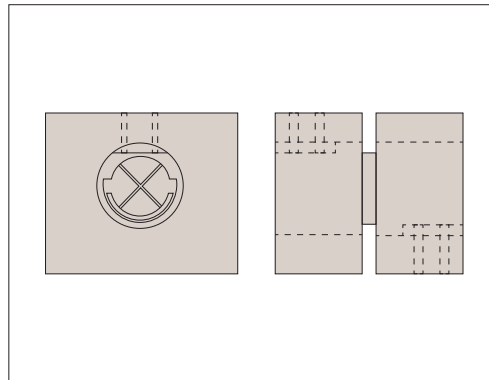

Locator flats

Locator flats with cup point set screws may be used to orientate and securely clamp the bearing in place. Hole size should be 0.0005" to 0.0010" larger than the bearing.



The linearity of the bearings (being the rotational deflection of the pivot v the torque required to induce the deflection) is relatively constant for angles of rotation up to 15°. We define hysteresis as the difference between the zero position when the bearing is deflected to a plus angle then relieved and then deflected to a negative angle then relieved. Comparing these two positions is the angle of hysteresis (see graphs below).

Series 10 - Max. $\theta \pm 15.0^\circ$

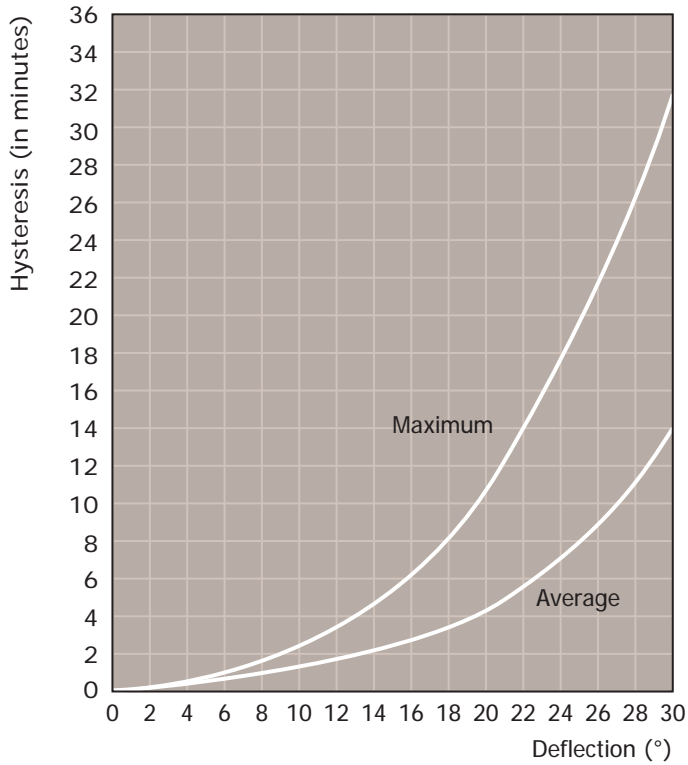

Series 20 - Max. $\theta \pm 7.5^\circ$

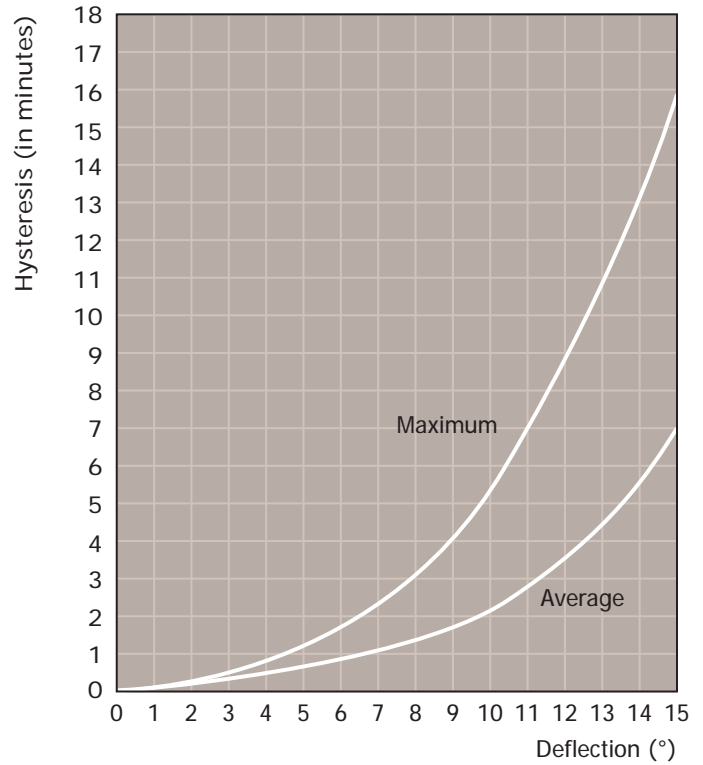

Series 30 - Max. $\theta \pm 3.7^\circ$

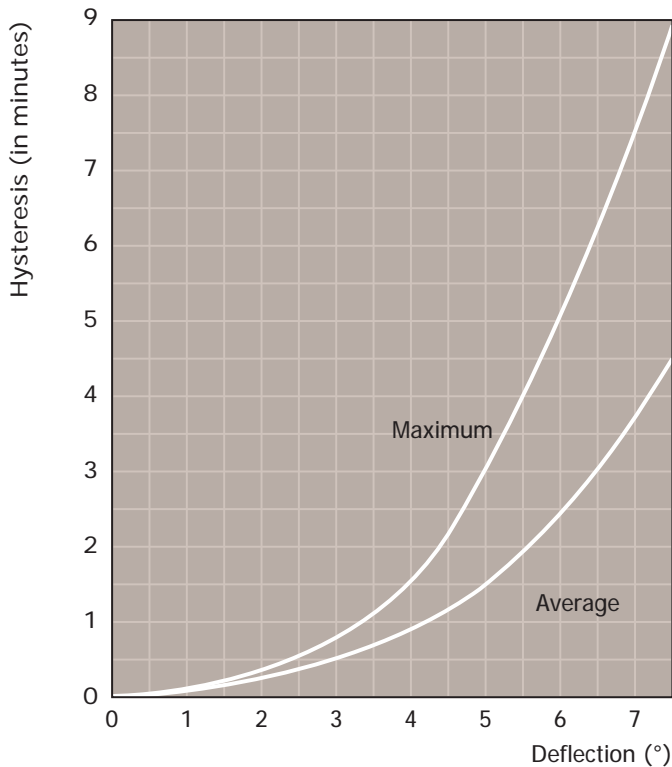

The rotation of the bearing sleeve segments is achieved by bending flat spring beams. This causes a slight radial shift in the sleeve segment. For small angle of rotations (eg 2°) the shift is minimal (around 0.2% of the bearing diameter). However this can increase up to 1% of the bearing diameter at a rotation of 15° (see graph below).

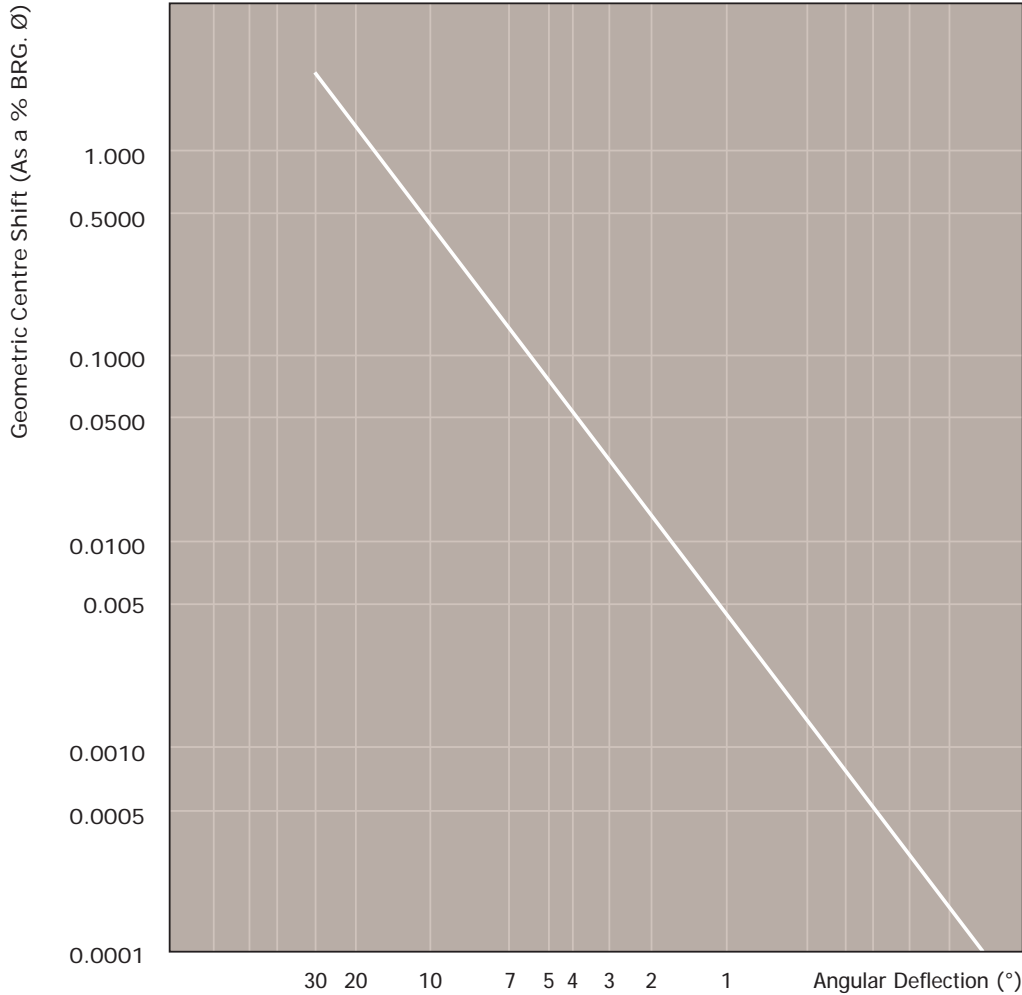

Flexure Pivot Bearings from Automation Components