

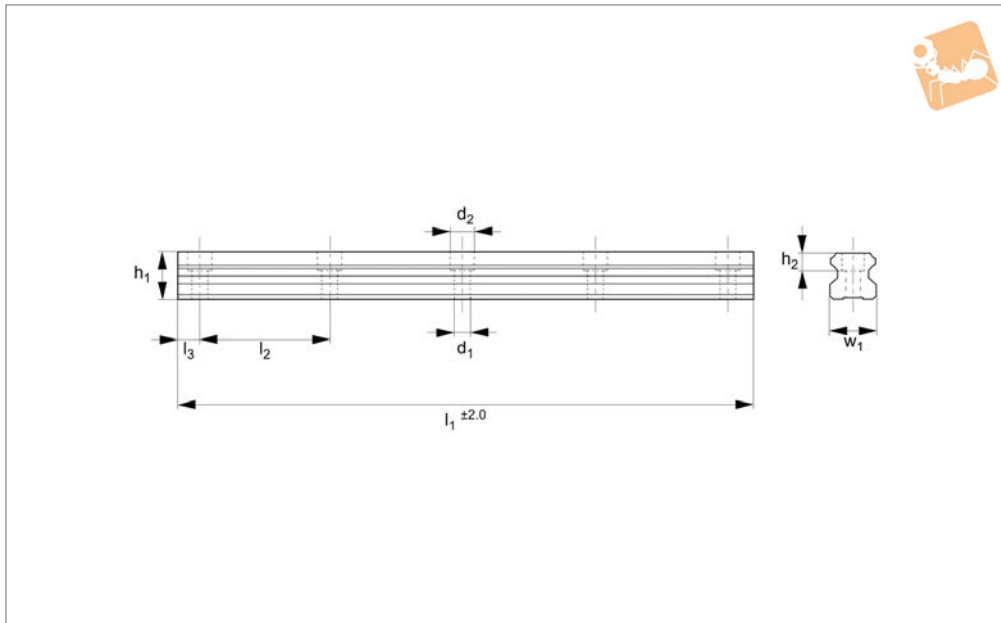

45mm Linear Guide Rail

standard

Linear Guide-ways



L1016.45

LINEAR GUIDEWAYS

Material

Hardened and ground steel (typically 60 HRC).

part nos. L1016.F (flanged) and L1016.U (unflanged).

Other rail lengths on request.
Weight: 12,3 Kg/m.

Tips

Plastic screw covers issued with the rails to protect the holes from debris.

Technical Notes

For carriages to suit the required load see

Order No.	Rail size	l_1	h_1	l_2	w_1	l_3	h_2	d_1	d_2	For screws	Weight kg
L1016.45-0255	45	255	31.1	105	45	22.5	17	14	20	M12	3.14
L1016.45-0360	45	360	31.1	105	45	22.5	17	14	20	M12	4.43
L1016.45-0465	45	465	31.1	105	45	22.5	17	14	20	M12	5.72
L1016.45-0570	45	570	31.1	105	45	22.5	17	14	20	M12	7.01
L1016.45-0675	45	675	31.1	105	45	22.5	17	14	20	M12	8.30
L1016.45-0780	45	780	31.1	105	45	22.5	17	14	20	M12	9.59
L1016.45-0885	45	885	31.1	105	45	22.5	17	14	20	M12	10.89
L1016.45-0990	45	990	31.1	105	45	22.5	17	14	20	M12	12.18
L1016.45-1095	45	1095	31.1	105	45	22.5	17	14	20	M12	13.47
L1016.45-1200	45	1200	31.1	105	45	22.5	17	14	20	M12	14.76
L1016.45-1305	45	1305	31.1	105	45	22.5	17	14	20	M12	16.05
L1016.45-1410	45	1410	31.1	105	45	22.5	17	14	20	M12	17.34
L1016.45-1515	45	1515	31.1	105	45	22.5	17	14	20	M12	18.63
L1016.45-1620	45	1620	31.1	105	45	22.5	17	14	20	M12	19.93
L1016.45-1725	45	1725	31.1	105	45	22.5	17	14	20	M12	21.22
L1016.45-1830	45	1830	31.1	105	45	22.5	17	14	20	M12	22.51
L1016.45-1935	45	1935	31.1	105	45	22.5	17	14	20	M12	23.80
L1016.45-2040	45	2040	31.1	105	45	22.5	17	14	20	M12	25.09
L1016.45-2145	45	2145	31.1	105	45	22.5	17	14	20	M12	26.38
L1016.45-2250	45	2250	31.1	105	45	22.5	17	14	20	M12	27.68
L1016.45-2355	45	2355	31.1	105	45	22.5	17	14	20	M12	28.97
L1016.45-2460	45	2460	31.1	105	45	22.5	17	14	20	M12	30.26
L1016.45-2565	45	2565	31.1	105	45	22.5	17	14	20	M12	31.55
L1016.45-2670	45	2670	31.1	105	45	22.5	17	14	20	M12	32.84
L1016.45-2775	45	2775	31.1	105	45	22.5	17	14	20	M12	34.13
L1016.45-2880	45	2880	31.1	105	45	22.5	17	14	20	M12	35.42
L1016.45-2985	45	2985	31.1	105	45	22.5	17	14	20	M12	36.72
L1016.45-3090	45	3090	31.1	105	45	22.5	17	14	20	M12	38.01
L1016.45-3195	45	3195	31.1	105	45	22.5	17	14	20	M12	39.30
L1016.45-3300	45	3300	31.1	105	45	22.5	17	14	20	M12	40.59
L1016.45-3405	45	3405	31.1	105	45	22.5	17	14	20	M12	41.88
L1016.45-3510	45	3510	31.1	105	45	22.5	17	14	20	M12	43.17



Order No.	Rail size	l_1	h_1	l_2	w_1	l_3	h_2	d_1	d_2	For screws	Weight kg
L1016.45-3615	45	3615	31.1	105	45	22.5	17	14	20	M12	44.46
L1016.45-3720	45	3720	31.1	105	45	22.5	17	14	20	M12	45.76
L1016.45-3825	45	3825	31.1	105	45	22.5	17	14	20	M12	47.05
L1016.45-3930	45	3930	31.1	105	45	22.5	17	14	20	M12	48.34
L1016.45-4000	45	4000	31.1	105	45	22.5	17	14	20	M12	49.20



L1016 Linear guideways

Linear guideways are widely used throughout industry for heavy-duty and precise applications.

Precision high load rails

The use of steel balls and the design of the carriages and guideways mean that the rails can accept very heavy loads and significant moment loads. Our rails have circular as opposed to friction coefficient, lower driving resistance, lower wear and lower energy consumption.

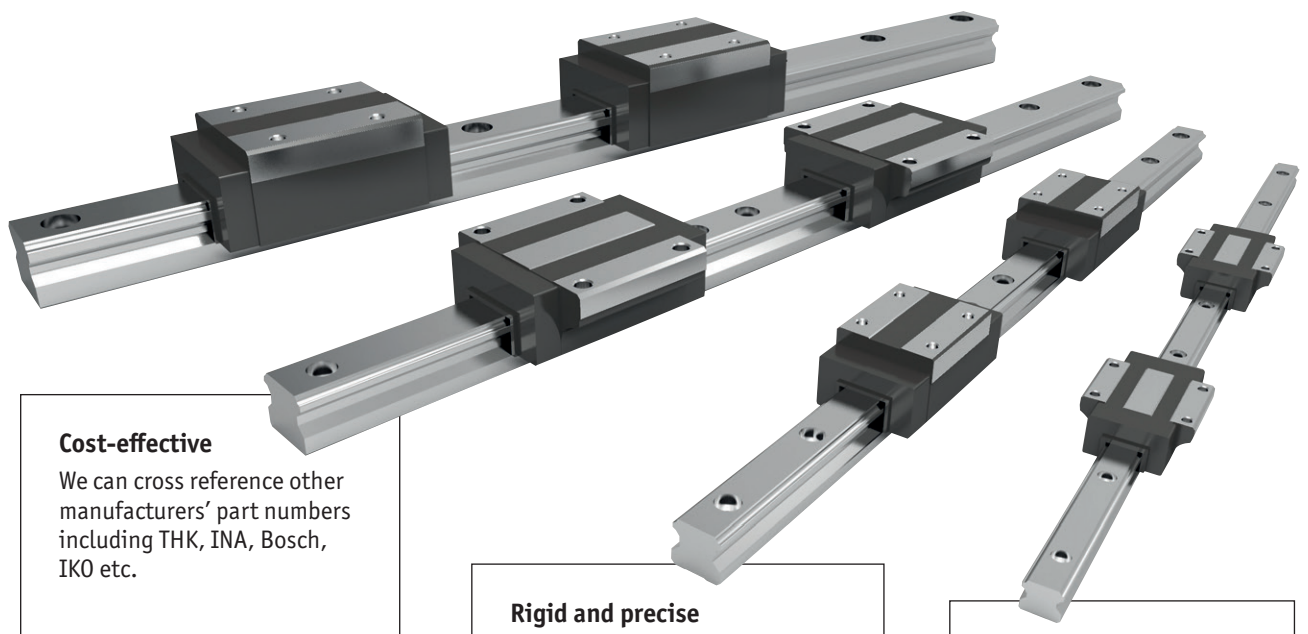

Cost-effective

We can cross reference other manufacturers' part numbers including THK, INA, Bosch, IKO etc.

Rigid and precise

- High load rating.
- High moment load capacity.

Stocked

7 rail profiles ready for same day despatch. Lengths up to 4 metres.

Rail sizes

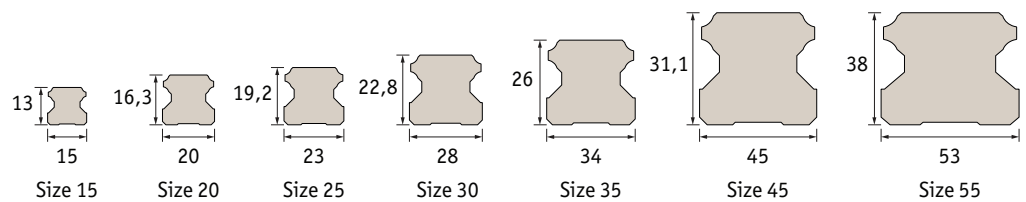



• Carriage types

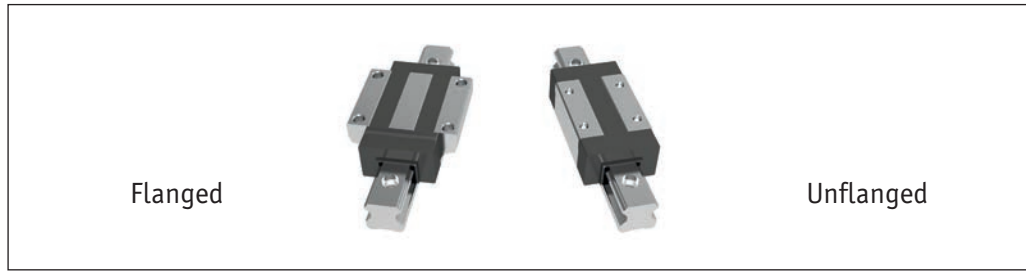

Carriage lengths

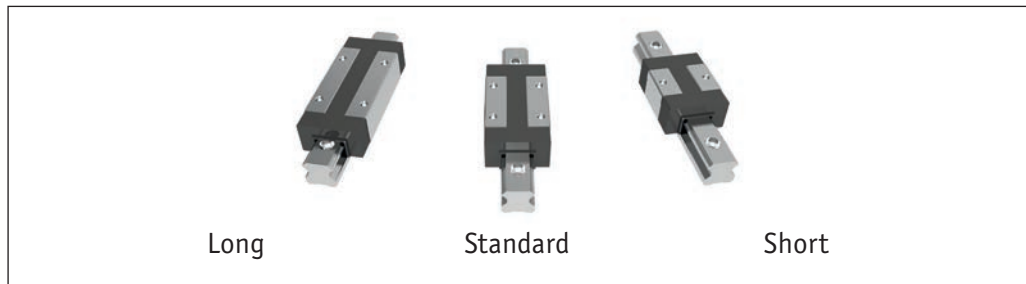

Rail types

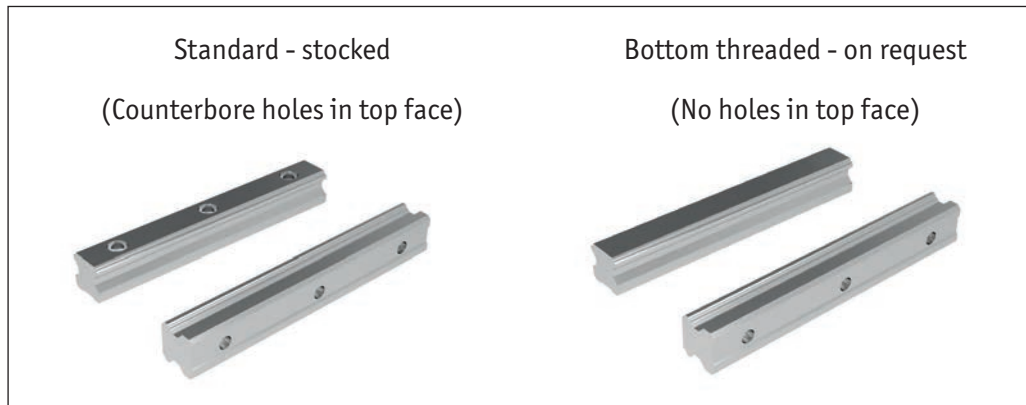

Linear Guideways from Automation Components

CAD - Download in 3 easy steps

Most of our products are available to download directly from our website. Get the CAD you need for your application in minutes, no registration required.

<p>Step 1: find the part you need</p> <p>Find the part or enter the Automation part number into the search bar.</p>	
<p>Step 2: Choose the CAD option</p> <p>Click on the CAD button below the product window to the right of the drawing.</p>	
<p>Step 3: Download your format</p> <p>Choose the the format you require, and download it to your computer.</p>	

Load capacities – explained

- A number of load figures are stated for load capacity:

Dynamic Load – this is the main figure considered for linear guideways. It is the moving load that the system can bear. It takes account of the total moving load as well as considerations such as impact, vibration and fatigue.

Static Load – this is a load that is constant for an extended time (i.e. the dead load the system can bear before any movement). It can be in tension or compression.

For these linear guideways the radial and axial load capacities are the same.

Moment loads are twisting loads generated by offset loads in either X, Y or Z planes. Moment loads can be reduced by adding further carriages or rails to reduce any twisting of the carriage due to the load offset.

Straightness of rails

- The measurements of the straightness of the system are taken from the running accuracy of the sliders over the length of the rails (given in microns) – see system precision page.
- For standard accuracy this equates to around 20 microns for a metre length, increasing to 35 microns for a 4 metre length.

What lengths can be provided?

- We have standard rail lengths. These are based on the hole pitch of the rails and end machining to provide an equidistant length to the first and last hole centre.
- However we can cut the rail (from stock) to any length required – we just need to know the distance required to the first hole.
- In general our cutting procedures allow for a ± 2 mm accuracy on the overall rail length. If greater accuracy than this is required then we have to machine the end accurately (rather than cut it) and this involves extra time and cost.
- Standard maximum length for each rail size is around 4 metres. Rails can be joined together but the preparation needs to be made in our workshop. The rails will be marked clearly with the ends to be placed adjacent to each other.

Installation

- The linear guideways are very accurate and as a result need to be installed on accurately prepared surfaces – please see installation instructions. If the two rails are installed parallel to each other, they need to be accurately aligned – see assembly precision page.
- If you are not able to prepare the surface as accurately as required you might want to consider using our Compact Rail system, as this has a master rail (T rail) and a slave rail (U rail) that allows for structural inaccuracies.

Mounting the carriages to the rails

- In general the carriages will be supplied separately to the rails. To install the carriage onto the rails, offer the carriage up to the rails and slide it onto the rail itself.

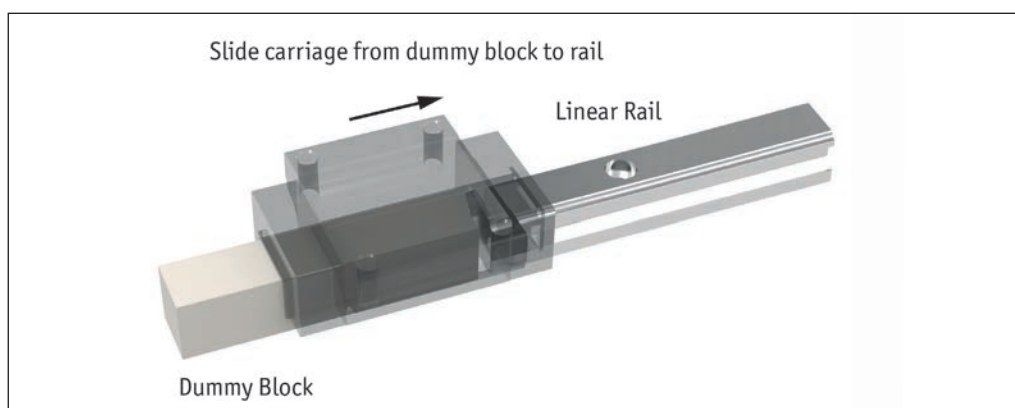



New ball chain technology

Our new and improved linear guideway systems include the latest “ball chain” technology with the following benefits:

- Higher maximum velocity.
- Lower heat generation
- Lower noise generation.
- Very smooth running.
- Optimised lubrication system
- Even load distribution
- Longer service life

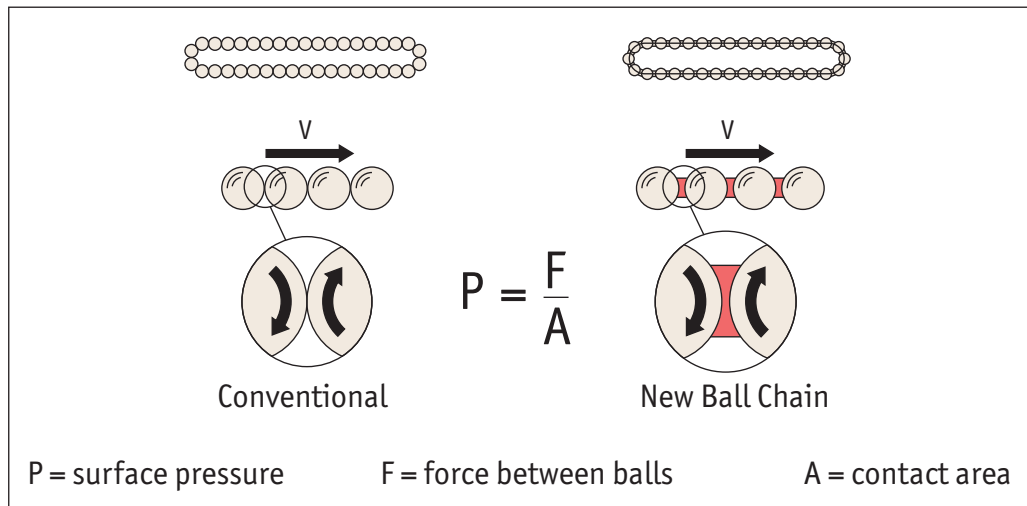

The rotating balls in conventional profile rail guides have point contact between each other. The rotation speed at the contact point is double the speed of the balls. The contact area (A) is so small that the surface pressure (P) tends towards infinity. This leads to heating and wear of the balls and the linear guide system.

The chain system in our new linear guides have a relatively large contact area (A), this significantly reduces the surface area pressure (P). The rotation speeds at the contact surfaces of ball and chain are the same. The ball chain is used to transport the lubricant and to create a lubrication film on the balls. The design of the carriage allows effective supply of lubricant from the lubricant connection to the circulation areas of the ball chains.

This design of the of the ball chain ends in connection with the spacer ball closes the circulation and makes the movement of the carriage smooth and quiet.

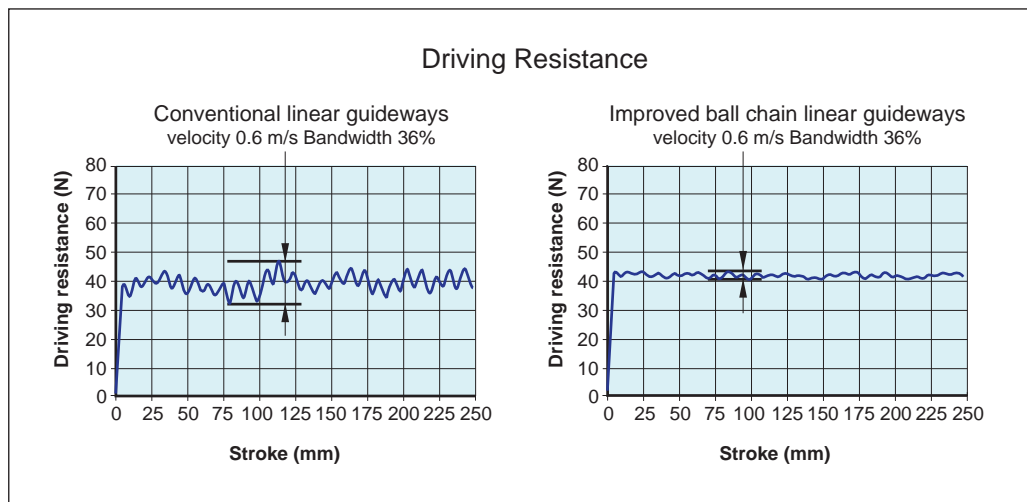

Linear Guideways from Automation Components

LINEAR GUIDEWAYS