

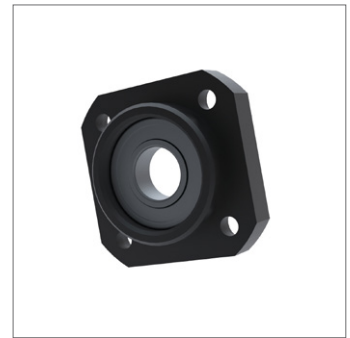

Floating Round Support Units (FF) for ball & lead screws

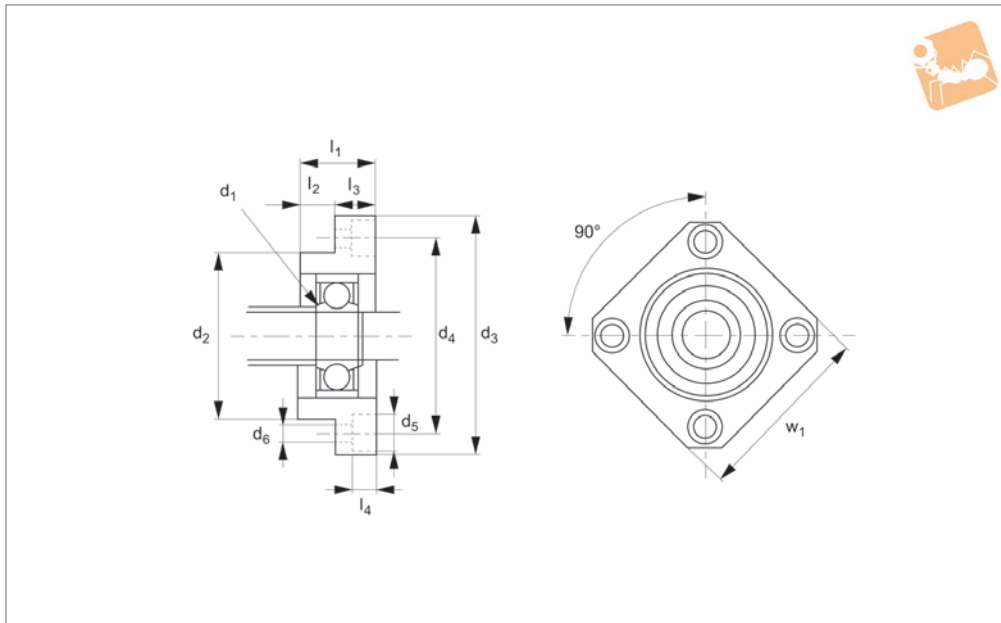

L1391

BEARING SUPPORTS

Material

Steel with black oxide finish. Bearings, sealed and lubricated for life.

Technical Notes

Standard units are suitable for ball screws

and lead screws to C5/C7 accuracy grade.

The bearings are not preloaded and have a max. axial clearance of 18µ.

For dimensions to machine the ends of the screws see technical pages.

Tips

Electroless nickel plated versions of these bearing mounts are available for clean room and other applications.

Order No.	For lead screw o.d dia.	For ball screw o.d dia.	d ₁ tol. H7	d ₂ tol. g6	d ₃	d ₄	d ₅	d ₆	l ₁
L1391.FF06	10	8	6	22	36	28	6.5	3.4	10
L1391.FF10	12	10	8	28	43	35	6.5	3.4	12
L1391.FF12	14 - 16	12	10	34	52	42	8.0	4.5	15
L1391.FF15	22 - 24	20	15	40	63	50	9.5	5.5	17
L1391.FF17	24	20 - 25	17	50	77	62	11.0	6.6	20
L1391.FF20	24	20 - 25	20	57	85	70	11.0	6.6	20
L1391.FF25	36	32 - 36	25	63	98	80	14.0	9.0	24
L1391.FF30	40	40 - 45	30	75	117	95	17.0	11.0	27

Order No.	l ₂	l ₃	l ₄	w ₁	Axial load kgf max.	rpm max.	Static load kgf max.
L1391.FF06	4	6	4.0	28	74	2	200
L1391.FF10	5	7	4.0	35	608ZZ	530	195
L1391.FF12	8	7	4.0	42	6000ZZ	610	214
L1391.FF15	8	9	5.5	52	6002ZZ	400	240
L1391.FF17	9	11	6.5	61	413	16000	1220
L1391.FF20	9	11	6.5	68	587	13000	1690
L1391.FF25	10	14	8.5	79	709	12000	2090
L1391.FF30	9	18	11.0	93	1082	7100	2760

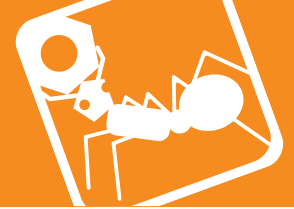
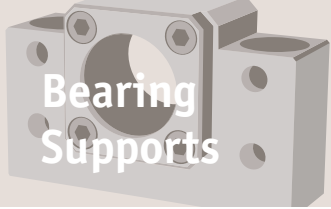

Notes

When inserting the screw shaft to the support unit, take care not to let the oil seal lip turn upward.

When securing the set piece with a hexagonal socket head set screw, apply an adhesive to the hexagonal socket head set screw before tightening it in order to prevent the screw from loosening. If planning to use the product in a harsh environment, it is also necessary to take measures to prevent other components/parts from loosening. Contact our Technical Department for details.

Installing the support unit

1. Install the fixed side support unit to the screw shaft.
2. After inserting the fixed side support unit, secure the lock nut using the fastening set piece and the hexagonal socket head set screw.
3. Attach the support side bearing to the screw shaft and secure the bearing using the snap ring, and then install the assembly to the housing on the supported side.

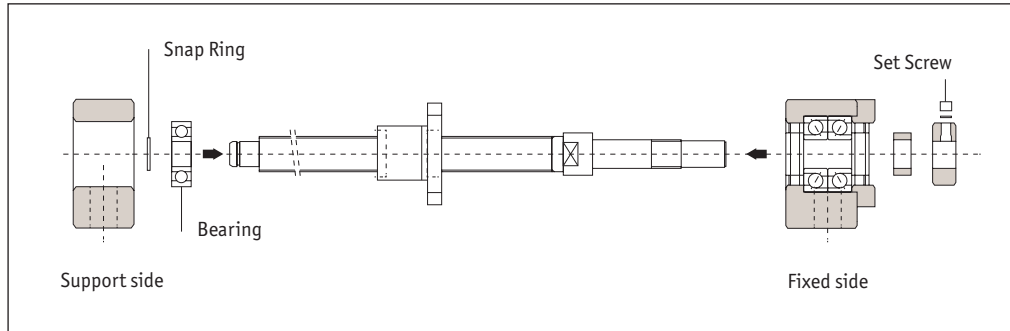

Installation onto the table and the base

1. If using a bracket when mounting the ball screw nut to the carriage, insert the nut into the bracket and temporarily fasten it.
2. Temporarily fasten the fixed side support unit to the base. In doing so, press the table toward the fixed side support unit to align the axial centre, and adjust the carriage so that it can travel freely.
3. Press the carriage toward the fixed side support unit to align the axial centre. Make the adjustment by reciprocating the table several times so that the nut travels slowly over the whole stroke, and temporarily secure the support unit to the base.

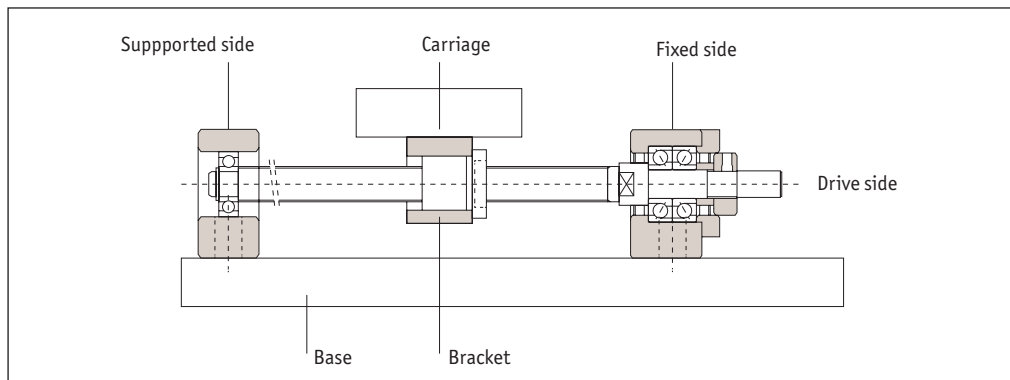

Checking the accuracy and fully fastening the support unit

1. While checking the runout of the ball screw shaft end and the axial clearance using a dial gauge, fully fasten the ball screw nut, the nut bracket, the fixed side support unit and the support side unit, in this order.

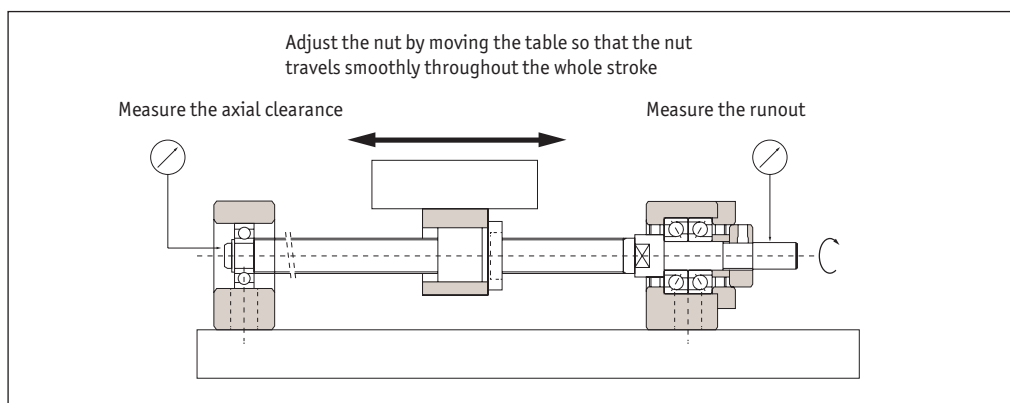

Notes

If using the fixed side support unit as the reference point, secure a clearance between the ball screw nut and the table or inside the bracket when making adjustment.

If using the table as a reference point, make the adjustment either by using the shim (for a square type support unit), or securing the clearance between the outer surface of the nut and the inner surface of the mounting section (for a round type support unit).



Connection with motor

1. Mount motor bracket to the base.
2. Connect the motor and the ball screw using a coupling (make sure the mounting accuracy is maintained).
3. Mount motor bracket to the base.

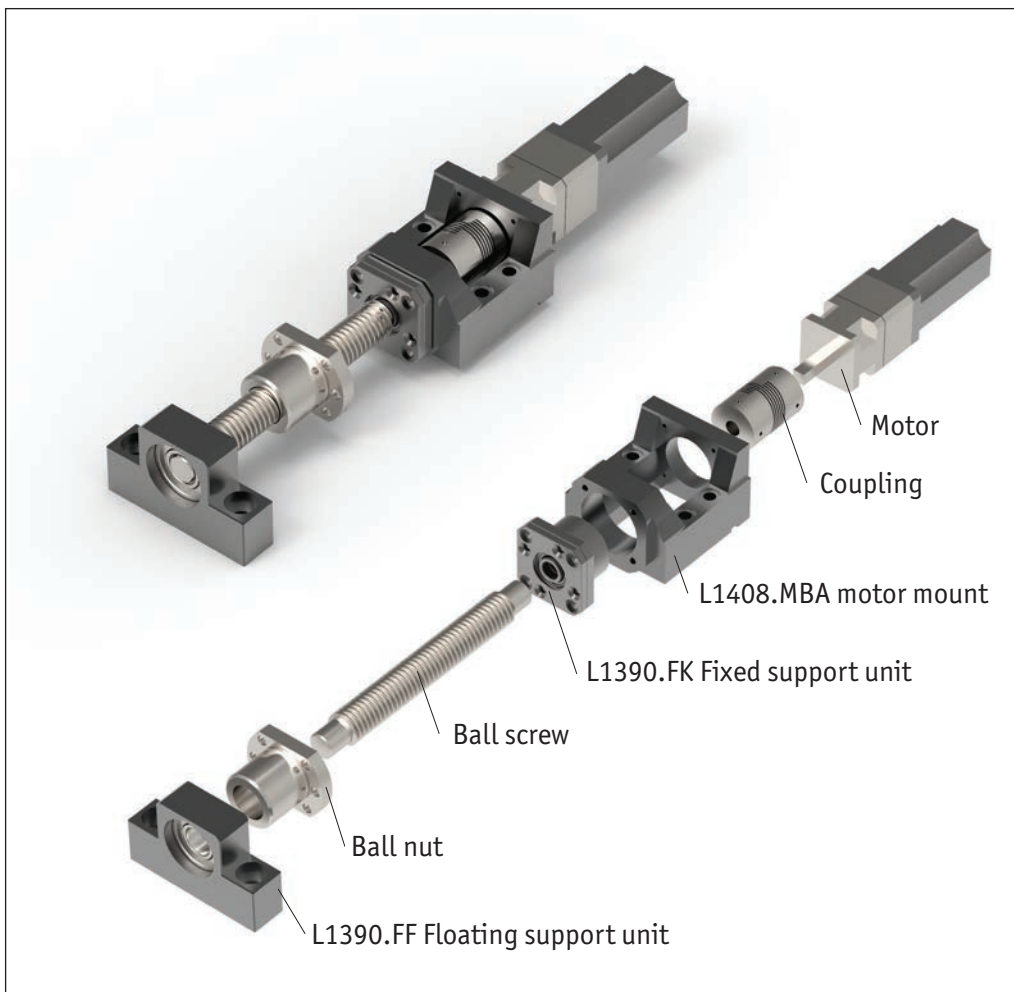
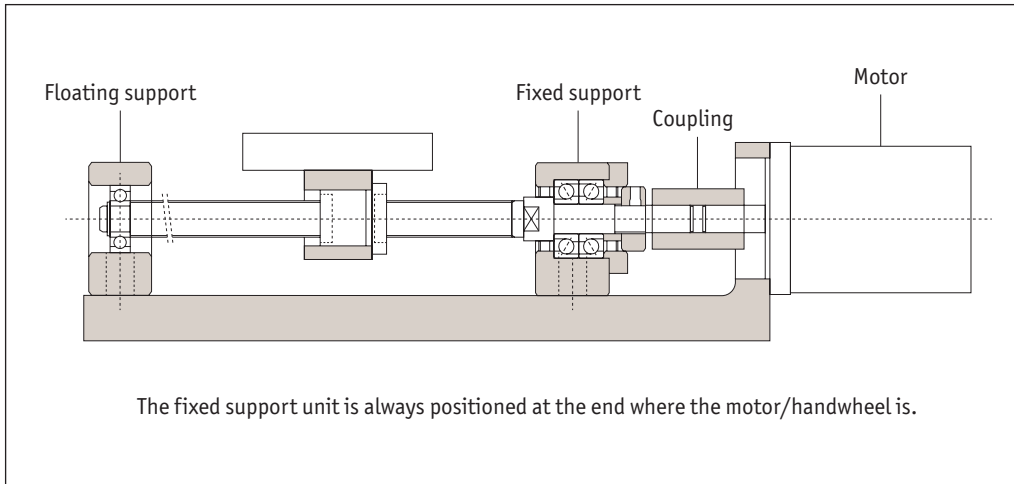

Bearing Supports from Automation Components

BEARING SUPPORTS

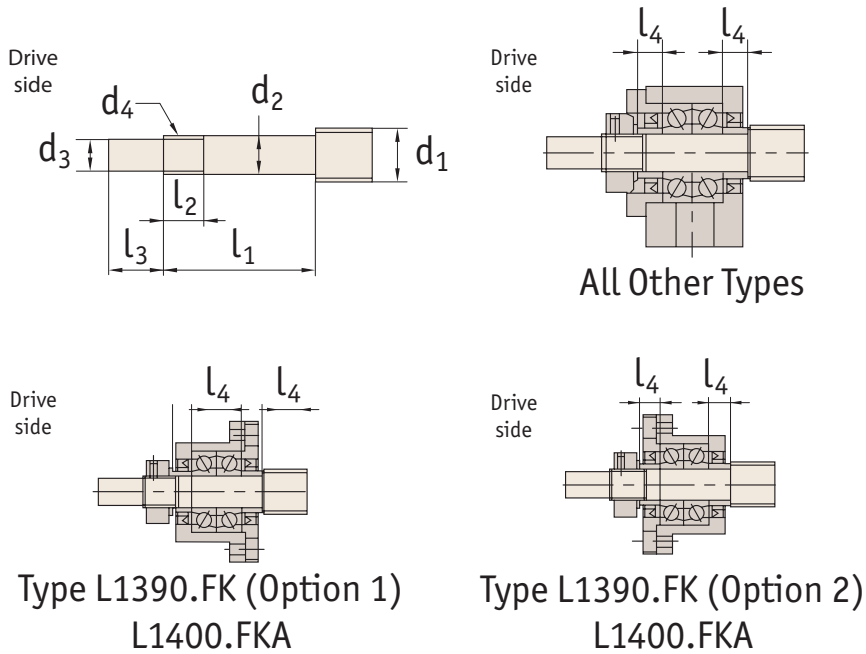

Part no.					Thread \varnothing	Shaft support \varnothing		For thread				
FK	EK	AK	FKA	LK	d_1	d_2	h_7	l_1	l_3	d_4	l_2	l_4
L1390.FK05	L1394.EK05	-	-	-	8	5 -0,008 -0,015	4	23	6	M5x0,5	7	3,5
L1390.FK06	L1394.EK06	-	-	-	8	6 -0,008 -0,015	4	28	8	M6x0,75	8	5,0
L1390.FK08	L1394.EK08	-	L1400.FKA08	L1402.LK08	10/12	8 -0,008 -0,015	6	32	9	M8x1,0	10	5,5
L1390.FK10	L1394.EK10	L1388.AK10	L1400.FKA10	L1402.LK08	12/14/15	10 -0,008 -0,015	8	35	15	M10x1,0	12	5,5
L1390.FK12	L1394.EK12	L1388.AK12	L1400.FKA12	L1402.LK08	14/15/16	12 -0,008 -0,015	10	35	15	M12x1,0	12	5,5
L1390.FK15	L1394.EK15	L1388.AK15	L1400.FKA15	L1402.LK08	18/20	15 -0,008 -0,017	12	48	20	M15x1,0	13	10,0
L1390.FK17	-	-	-	-	20/25	17 -0,008 -0,017	15	59	23	M17x1,0	17	10,0
L1390.FK20	L1394.EK20	L1388.AK20	L1400.FKA20	-	25/28/30	20 -0,008 -0,017	17	63	25	M20x1,0	15	11,0
L1390.FK25	-	-	-	-	30/32/36	25 -0,008 -0,017	20	76	30	M25x1,5	20	14,0
L1390.FK30	-	-	-	-	36/40	30 -0,008 -0,018	25	73	38	M30x1,5	25	9,0



Technical Information

Fixed side for unit type L1392.BK



Bearing
Supports

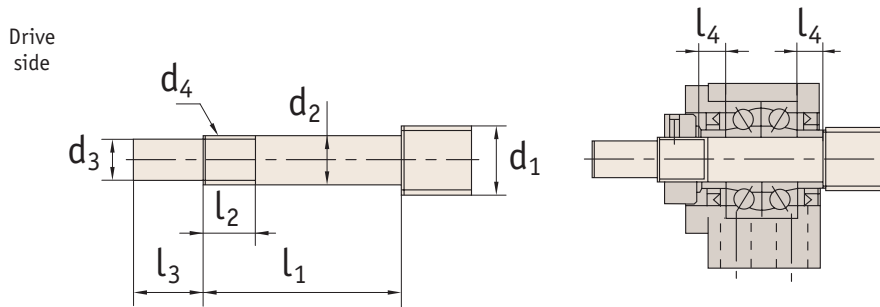

Part sno.	Thread ϕ	Shaft support ϕ					Thread		
		d_1	d_2	d_3	l_1	l_3	d_4	l_2	l_4
L1392.BK10	12/14/15	10	-0,008 -0,015	8	36	15	M10x1,0	12	5,5
L1392.BK12	14/15/16	12	-0,008 -0,015	10	36	15	M12x1,0	12	5,5
L1392.BK15	18/20	15	-0,008 -0,017	12	40	20	M15x1,0	12	6,0
L1392.BK17	20/25	17	-0,008 -0,017	15	53	23	M17x1,0	17	7,0
L1392.BK20	25/28	20	-0,008 -0,017	17	53	25	M20x1,0	15	8,0
L1392.BK25	32/36	25	-0,008 -0,017	20	66	30	M25x1,5	20	9,0
L1392.BK30	36/40	30	-0,008 -0,018	25	73	38	M30x1,5	25	9,0
L1392.BK35	45	35	-0,008 -0,018	30	82	45	M35x1,5	26	12,0
L1392.BK40	50	40	-0,008 -0,018	35	94	50	M40x1,5	30	15,0

ov-bearing-supports-fixed-side-unit-types-b-rmh-Updated-16-03-2023