

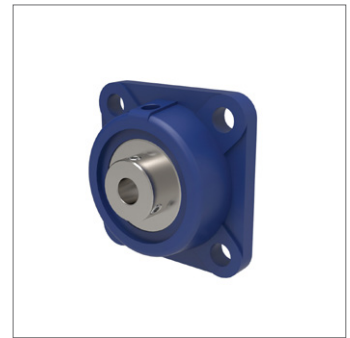

Square Flanged Bearing Units

cast iron

Bearing Mounts

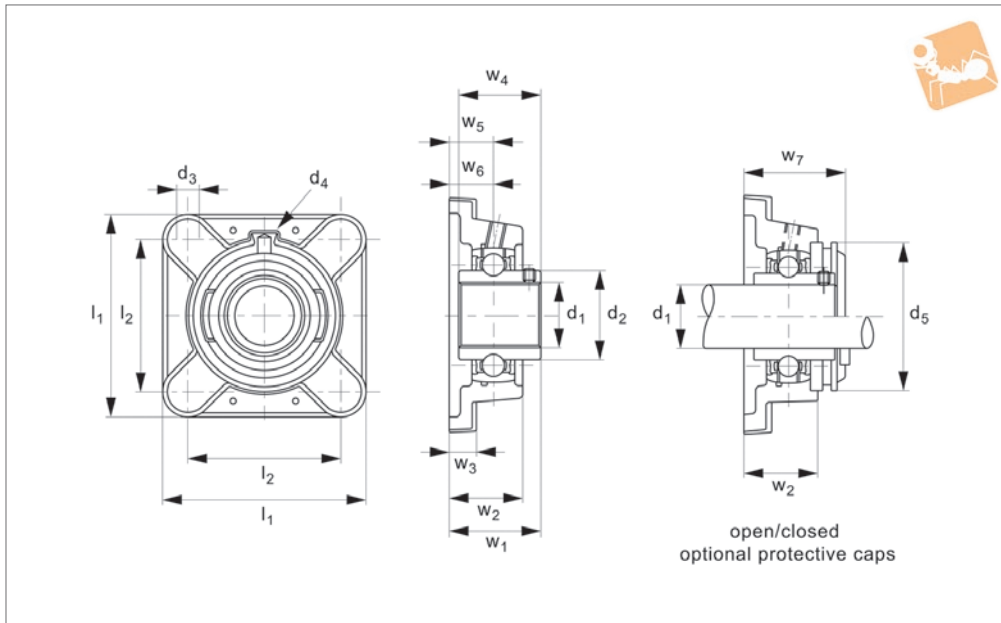

L1862

BEARING MOUNTS

Material

Cast iron (FG20 or FG25), passivated and painted blue (RAL 5010). Steel, self-aligning bearing units with double seals, lubricated for life.

Technical Notes

Self-aligning bearings, relubricatable.
Temperature range: -20°C to +120°C.
The max. axial load is 0.5 x radial static

load.

The housings are rated to take the maximum bearing loads.

For optional shaft end caps add suffixes:
-CO for one open protective cap (with seal) for through shafts
-CC for closed protective cap for shaft ends.

Tips

Shaft retention with two set screws (at

120° offset).

Used with h6 tolerance shafts (see our part no.s L1770-L1776).

Important Notes

For precise positioning of the flanged units they are provided with a rear centring bore and dowel pin location - please see technical pages for these dimensions.

Order No.	d ₁ for h6	l ₁	l ₂ ±0.7	d ₂	d ₃	d ₄	d ₅	w ₁	w ₂	Weight kg
L1862.012	12	86	63.5	29.0	11.5	R1/8"	54	37.3	29.5	0.7
L1862.015	15	86	63.5	29.0	11.5	R1/8"	54	37.3	29.5	0.7
L1862.017	17	86	63.5	29.0	11.5	R1/8"	54	37.3	29.5	0.5
L1862.020	20	86	63.5	29.0	11.5	R1/8"	54	37.3	29.5	0.7
L1862.025	25	95	70.0	34.0	11.5	R1/8"	60	38.7	30.0	0.8
L1862.030	30	108	82.5	40.3	11.5	R1/8"	70	42.2	33.5	1.2
L1862.035	35	118	92.0	48.0	14.0	R1/8"	80	46.4	36.0	1.6
L1862.040	40	130	101.5	53.0	14.0	R1/8"	88	54.2	39.5	2.1
L1862.045	45	137	105.0	57.2	14.0	R1/8"	95	54.2	40.0	2.2
L1862.050	50	143	111.0	61.8	18.0	R1/8"	100	60.6	44.0	2.6
L1862.055	55	162	130.0	69.0	18.0	R1/8"	110	64.4	48.5	3.7
L1862.060	60	175	143.0	74.9	18.0	R1/8"	120	73.7	53.5	4.9
L1862.065	65	188	150.0	82.0	18.0	R1/8"	132	77.7	56.0	6.0
L1862.070	70	188	150.0	86.5	18.0	R1/8"	-	82.4	56.0	6.2
L1862.075	75	197	153.0	91.5	23.0	R1/8"	-	85.8	59.0	6.3
L1862.080	80	197	153.0	98.0	23.0	R1/8"	-	90.6	61.0	7.1
L1862.090	90	235	187.0	111.0	23.0	R1/8"	-	80.1	45.0	10.4

Order No.	w ₃	w ₄	w ₅ ±0.5	w ₆	w ₇	Dyn. radial load C kN max.	Static radial load C ₀ kN max.	Speed rpm max.
L1862.012	10.0	31.0	19.0	12.7	42.8	12.80	6.65	6500
L1862.015	10.0	31.0	19.0	12.7	42.8	12.80	6.65	6500
L1862.017	10.0	31.0	19.0	12.7	42.8	12.80	6.65	6500
L1862.020	10.0	31.0	19.0	12.7	42.8	12.80	6.65	6500
L1862.025	11.0	32.0	19.0	14.3	42.9	14.00	7.88	6500
L1862.030	12.0	38.1	20.0	15.9	46.9	19.50	11.20	4500



Order No.	w ₃	w ₄	w ₅ ±0.5	w ₆	w ₇	Dyn. radial load C kN max.	Static radial load C ₀ kN max.	Speed rpm max.
L1862.035	12.5	42.9	21.0	17.5	50.2	25.70	15.20	4500
L1862.040	13.0	49.2	24.0	19.0	57.9	29.60	18.20	3500
L1862.045	13.0	49.2	24.0	19.0	58.4	31.85	20.80	3500
L1862.050	13.0	51.6	28.0	19.0	65.8	35.10	23.20	3000
L1862.055	15.0	55.6	31.0	22.2	69.1	43.55	29.20	3000
L1862.060	16.0	65.1	34.0	25.4	78.4	52.50	32.80	2500
L1862.065	18.0	95.1	38.0	25.4	77.4	57.20	40.00	2500
L1862.070	18.0	74.6	38.0	30.2	-	62.00	45.00	2500
L1862.075	20.0	77.8	41.3	33.3	-	66.00	49.50	2500
L1862.080	20.0	82.6	41.3	33.3	-	72.50	54.20	2500
L1862.090	22.0	96.0	23.8	39.7	-	96.00	71.50	2500



Bearing Supports from Automation Components

Housing material options



Cast iron housing

Standard version, passivated and painted $\varnothing 12-120\text{mm}$.

Stainless steel housing

Stainless AISI 304, $\varnothing 12-60\text{mm}$.

Thermoplastic housing

Food grade applications, smooth PBT resin material, $\varnothing 20-40\text{mm}$.

Pillow Bearings

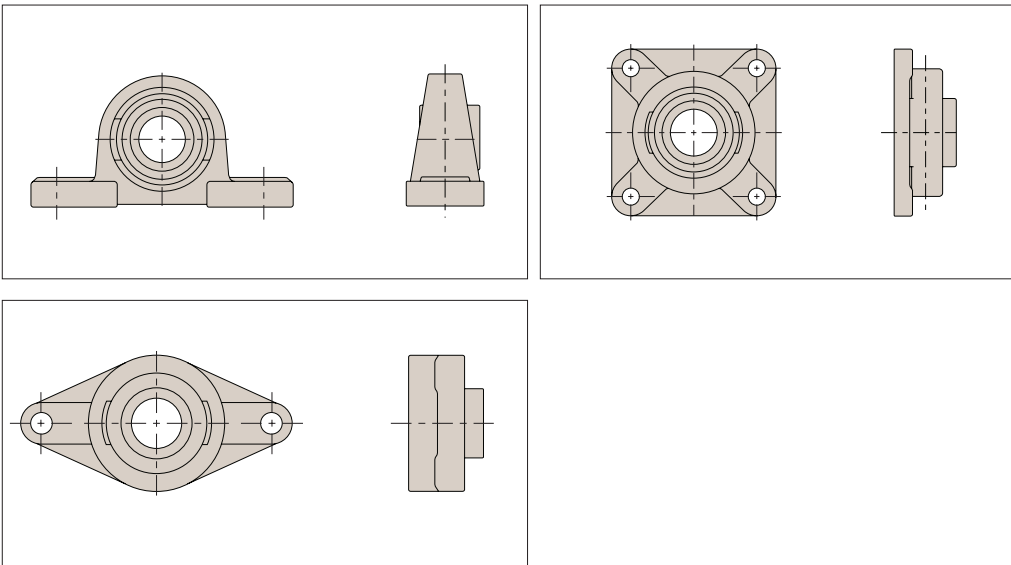

Use with Automation linear shafts L1770-L1774

Options

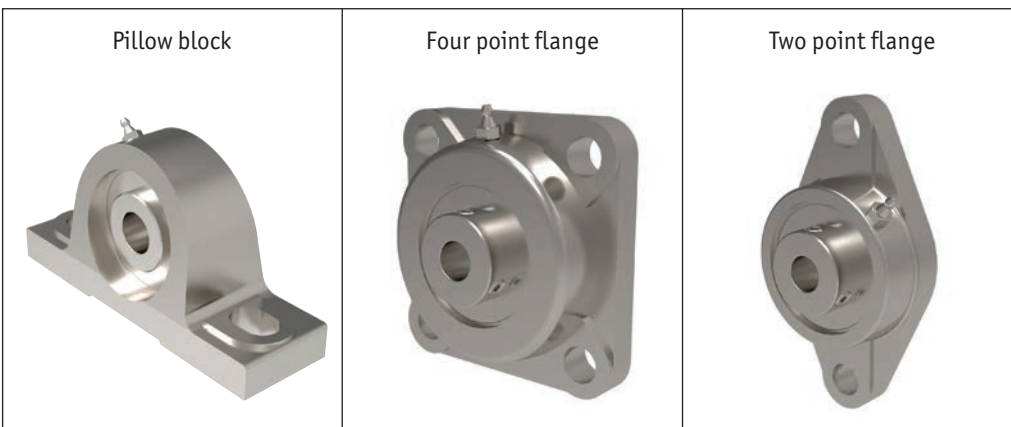



For cast iron housings

- Single row radial contact self-aligning bearings (steel 100Cr6).
- Re-lubricatable.
- Fixing to shaft via set screw.
- Operating temperature range -20° to $+100^{\circ}$.

For stainless & thermoplastic housings

- Single row radial contact self-aligning bearings (stainless steel AISI 440C), stainless steel cage.
- Lubricated with food grade grease.
- Fixing to shaft via set screw.

Shaft fixing set screw

2 set screws at 120° with hexagon socket and knurled cup point, recommended shaft tolerance h6/h7.

Set screw	Max. tightening torque (Nm)	Hexagon socket A/F
M5 x 0,8	3,5	2,5
M6 x 1	5,5	3,0
M8 x 1	11,5	4,0
M10 x 1,25	22,0	5,0
M12 x 1,25	33,0	6,0
M14 x 1,5	42,0	7,0
M16 x 1,5	64,0	8,0
M18 x 1,5	75,0	9,0
M20 x 1,5	120,0	10,0

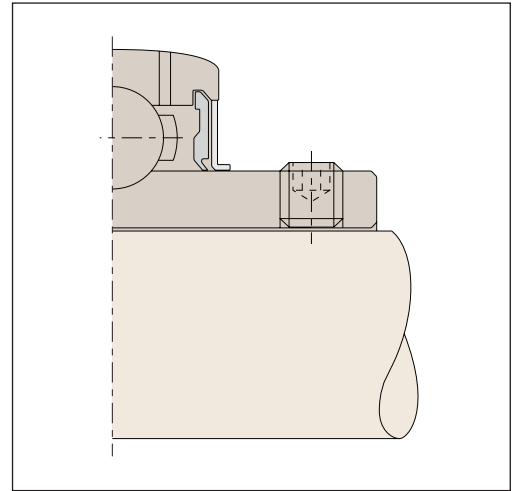

Lubrication

Our units are lubricated for life. If re-lubrication is necessary (because of severe operating conditions), use a lithium soap base with a viscosity of $100\text{mm}^2/\text{s}$ at 40°C .

Installation

Shaft misalignment is compensated to a certain degree by the shaft-aligning bearings.

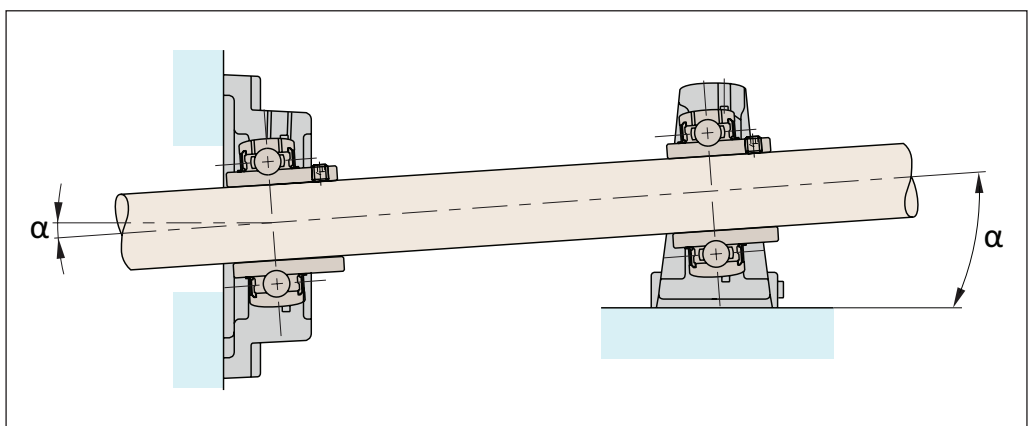

If re-lubrication required

$$\alpha = \pm 2^{\circ}$$

If no re-lubrication

$$\alpha = \pm 5^{\circ}$$

When using protective end caps

$$\alpha = \pm 5^{\circ}$$



Cast Iron Bearing Units

Equivalent load ratings

Bearing Support Units



The radial loads of the cast iron bearing supports are limited by the bearings themselves – the housings can withstand the maximum loads.

Please see the part numbers for dynamic and static radial loads. The maximum axial loads are 50% of the maximum static radial loads. The standard bearing have a C3 clearance.

Bore nominal size (mm)		Radial bearing clearance (μ) C3	
Above	Up to	Min.	Max.
10	18	11	25
18	24	13	28
24	30	13	28
30	40	15	33
40	50	18	36
50	65	23	43
65	80	25	51
80	100	30	58
100	120	36	66
120	140	41	81

When choosing a suitable bearing size – this depends on the load and speed required.

If the load acts mainly whilst the bearing rotates, then it is a dynamic load, if it acts mainly during no movement or low speeds, then it is a static load.

The maximum for both of these, for each bearing, is shown in the part tables.

Dynamic equivalent loads:

For some situations the bearing will have to withstand both radial and axial loads and we then need to calculate an equivalent dynamic load using the following equation:

$$L = X \cdot F_r + Y \cdot F_a \text{ (kN)}$$

- P = Dynamic equivalent load (kN)
- F_r = Actual radial load (kN)
- F_a = Actual axial load (kN)
- X = Radial factor
- Y = Axial factor

Load ratio table 1:

$\frac{F_a}{C_{or}}$	e	$\frac{F_a}{F_r} \leq e$		$\frac{F_a}{F_r} > e$	
		X	Y	X	Y
0,014	0,19				2,30
0,028	0,22				1,99
0,056	0,26				1,71
0,084	0,28				1,55
0,110	0,30	1	0	0,56	1,45
0,170	0,34				1,31
0,280	0,38				1,15
0,420	0,42				1,04
0,560	0,44				1,00

e = Limiting value

C_{or} = Radial static load rating (see dimension tables for ball bearing units)

Bearing Supports from Automotion Components



Static equivalent loads

For situations where there are radial and axial loads on the static or slow moving bearings:

$$P_0 = X_0 \cdot F_r + Y_0 \cdot F_a \text{ (kN)}$$

$$P_0 = F_r \quad \text{if} \quad \frac{F_a}{F_r} \leq 0.8$$

P_0 = Static equivalent load (kN) For all bearing inserts the following applies:
 X_0 = Static radial factor $X_0 = 0.6$
 Y_0 = Static axial factor $Y_0 = 0.5$

Using the ratio **fs**, it can be checked if sufficient static dimensioning for the insert has been ensured:

$$fs = \frac{C_{0r}}{P_0}$$

Some standard values are:

- fs** = 0.7 Minimal demands for running smoothness and rotating movement
- fs** = 1.0 occasional rotating bearing, normal demands for running
- fs** = 2.0 smoothness, high demands for running smoothness

It should be noted that this ratio does not provide any assurance against a break or similar, but instead it is assurance against excessive local deformation in the rolling contact (ball/raceway).

Calculating bearing life

When calculating bearing life for bearing units, the following applies:

$$L_{10} = \left(\frac{C_r}{p} \right)^3 \quad \text{(10}^6 \text{ revolutions)}$$

If the bearing life should be specified in hours, the following applies:

$$L_{10h} = \left(\frac{C_r}{p} \right)^3 \cdot \frac{10^6}{60n} \quad \text{(h)}$$

n = speed (min⁻¹)