



Thermoplastic End Caps

open & closed



Bearing Mounts

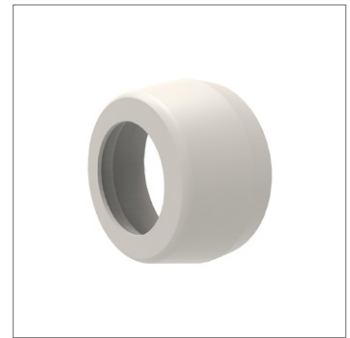
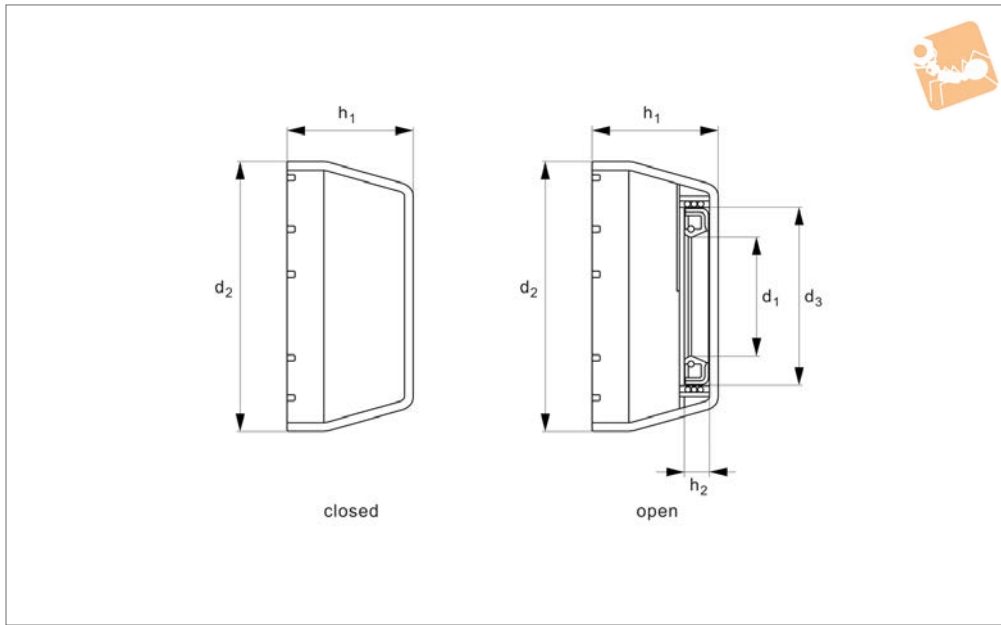

L1879

BEARING MOUNTS

Material

White SR50 polypropene, with smooth surfaces.

Technical Notes

Temperature range: -15°C to +110°C.
Resistant to a wide range of chemicals.

Provide good protection against bacterial contamination.

Order No.	Type	d ₁	d ₂	d ₃	h ₁	h ₂
L1879.200-CC	Closed	20	50.1	-	23	7
L1879.250-CC	Closed	25	55.0	-	25	7
L1879.300-CC	Closed	30	64.0	-	30	7
L1879.350-CC	Closed	35	74.5	-	32	7
L1879.400-CC	Closed	40	84.0	-	37	7
L1879.200-CO	Open	20	50.1	32	23	7
L1879.250-CO	Open	25	55.0	37	25	7
L1879.300-CO	Open	30	64.0	42	30	7
L1879.350-CO	Open	35	74.5	47	32	7
L1879.400-CO	Open	40	84.0	52	37	7



Housing material options

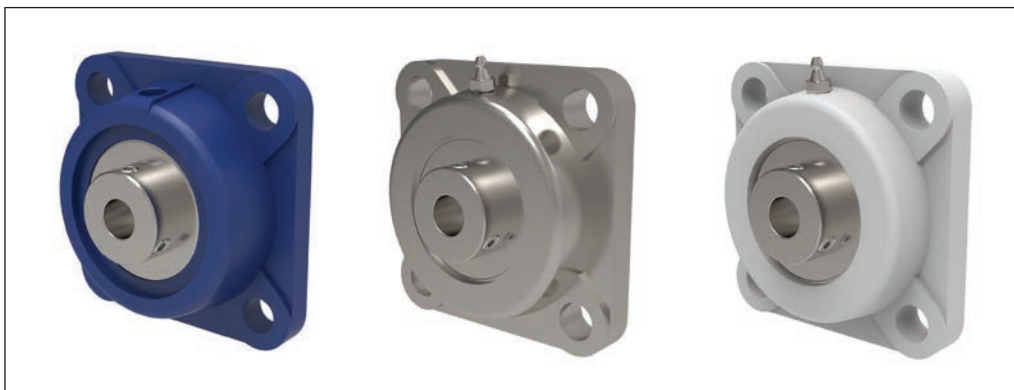

Cast iron housing
Standard version, passivated and painted $\varnothing 12-120\text{mm}$.

Stainless steel housing
Stainless AISI 304, $\varnothing 12-60\text{mm}$.

Thermoplastic housing
Food grade applications, smooth PBT resin material, $\varnothing 20-40\text{mm}$.

Pillow Bearings

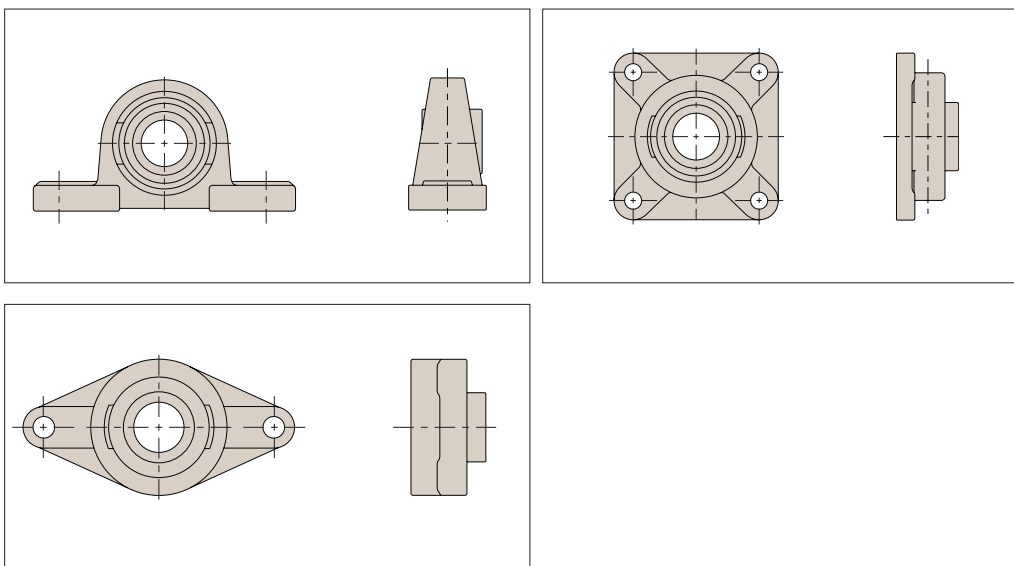

Use with Automation linear shafts L1770-L1774

Options

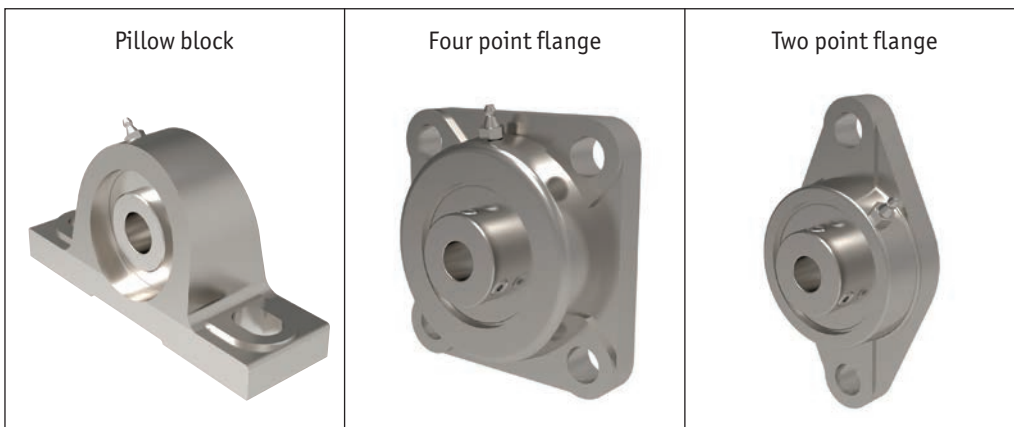

Bearing Supports from Automation Components

BEARING MOUNTS



For cast iron housings

- Single row radial contact self-aligning bearings (steel 100Cr6).
- Re-lubricatable.
- Fixing to shaft via set screw.
- Operating temperature range -20° to +100°.

For stainless & thermoplastic housings

- Single row radial contact self-aligning bearings (stainless steel AISI 440C), stainless steel cage.
- Lubricated with food grade grease.
- Fixing to shaft via set screw.

Shaft fixing set screw

2 set screws at 120° with hexagon socket and knurled cup point, recommended shaft tolerance h6/h7.

Set screw	Max. tightening torque (Nm)	Hexagon socket A/F
M5 x 0,8	3,5	2,5
M6 x 1	5,5	3,0
M8 x 1	11,5	4,0
M10 x 1,25	22,0	5,0
M12 x 1,25	33,0	6,0
M14 x 1,5	42,0	7,0
M16 x 1,5	64,0	8,0
M18 x 1,5	75,0	9,0
M20 x 1,5	120,0	10,0

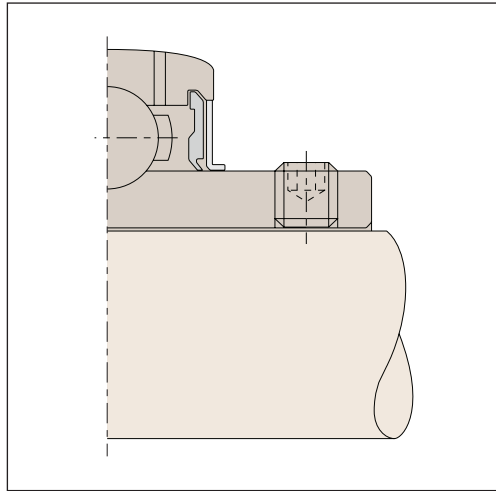

Lubrication

Our units are lubricated for life. If re-lubrication is necessary (because of severe operating conditions), use a lithium soap base with a viscosity of 100mm²/s at 40°C.

Installation

Shaft misalignment is compensated to a certain degree by the shaft-aligning bearings.

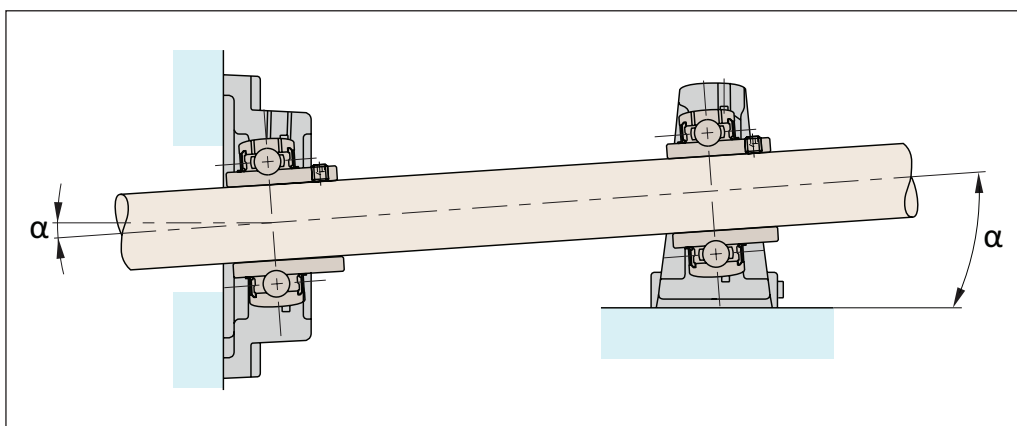

If re-lubrication required

$$\alpha = \pm 2^\circ$$

If no re-lubrication

$$\alpha = \pm 5^\circ$$

When using protective end caps

$$\alpha = \pm 5^\circ$$

Bearing Supports from Automation Components

BEARING MOUNTS



The radial loads of the cast iron bearing supports are limited by the bearings themselves – the housings can withstand the maximum loads.

Please see the part numbers for dynamic and static radial loads. The maximum axial loads are 50% of the maximum static radial loads. The standard bearing have a C3 clearance.

Bore nominal size (mm)		Radial bearing clearance (μ) C3	
Above	Up to	Min.	Max.
10	18	11	25
18	24	13	28
24	30	13	28
30	40	15	33
40	50	18	36
50	65	23	43
65	80	25	51
80	100	30	58
100	120	36	66
120	140	41	81

When choosing a suitable bearing size – this depends on the load and speed required.

If the load acts mainly whilst the bearing rotates, then it is a dynamic load, if it acts mainly during no movement or low speeds, then it is a static load.

The maximum for both of these, for each bearing, is shown in the part tables.

Bearing Supports from Automation Components

Dynamic equivalent loads:

For some situations the bearing will have to withstand both radial and axial loads and we then need to calculate an equivalent dynamic load using the following equation:

$$L = X \cdot F_r + Y \cdot F_a \text{ (kN)}$$

- P = Dynamic equivalent load (kN)
- F_r = Actual radial load (kN)
- F_a = Actual axial load (kN)
- X = Radial factor
- Y = Axial factor

Load ratio table 1:

F _a C _{0r}	e	F _a /F _r ≤ e		F _a /F _r > e	
		X	Y	X	Y
0,014	0,19				2,30
0,028	0,22				1,99
0,056	0,26				1,71
0,084	0,28				1,55
0,110	0,30	1	0	0,56	1,45
0,170	0,34				1,31
0,280	0,38				1,15
0,420	0,42				1,04
0,560	0,44				1,00

e = Limiting value

C_{0r} = Radial static load rating (see dimension tables for ball bearing units)



Static equivalent loads

For situations where there are radial and axial loads on the static or slow moving bearings:

$$P_0 = X_0 \cdot F_r + Y_0 \cdot F_a \text{ (kN)}$$

$$P_0 = F_r \quad \text{if} \quad \frac{F_a}{F_r} \leq 0.8$$

P_0 = Static equivalent load (kN)	For all bearing inserts the following applies:
X_0 = Static radial factor	$X_0 = 0.6$
Y_0 = Static axial factor	$Y_0 = 0.5$

Using the ratio **fs**, it can be checked if sufficient static dimensioning for the insert has been ensured:

$$fs = \frac{C_{0r}}{P_0}$$

Some standard values are:

- fs** = 0.7 Minimal demands for running smoothness and rotating movement
- fs** = 1.0 occasional rotating bearing, normal demands for running
- fs** = 2.0 smoothness, high demands for running smoothness

It should be noted that this ratio does not provide any assurance against a break or similar, but instead it is assurance against excessive local deformation in the rolling contact (ball/raceway).

Calculating bearing life

When calculating bearing life for bearing units, the following applies:

$$L_{10} = \left(\frac{C_r}{p} \right)^3 \quad \text{(10}^6 \text{ revolutions)}$$

If the bearing life should be specified in hours, the following applies:

$$L_{10h} = \left(\frac{C_r}{p} \right)^3 \cdot \frac{10^6}{60n} \quad \text{(h)}$$

n = speed (min⁻¹)