

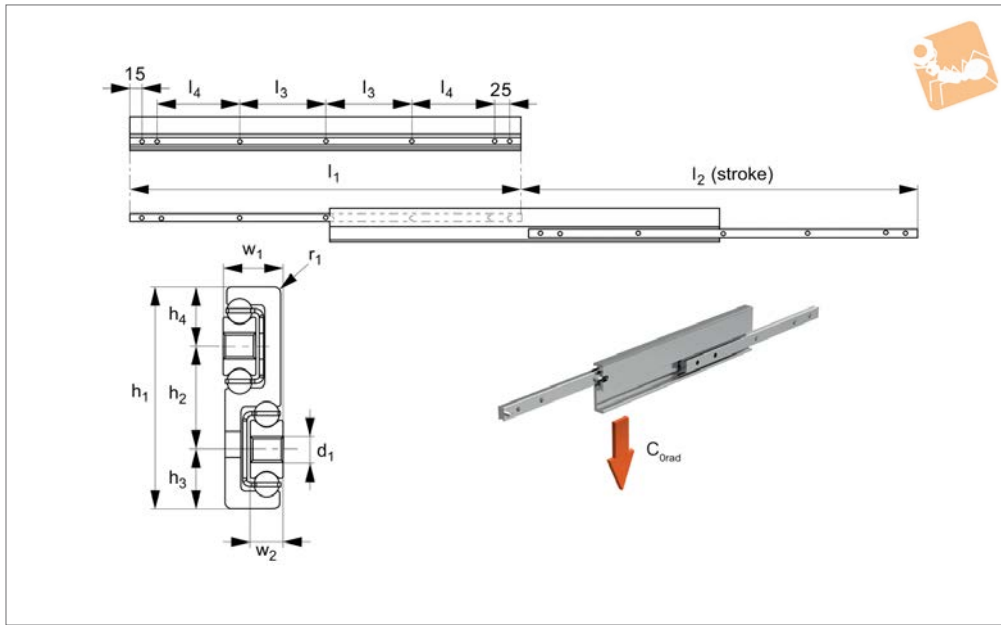

Fully Telescopic Slides LTF

Telescopic Slides

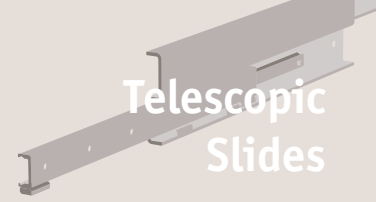

L1992

TELESCOPIC SLIDES

Material

Cold drawn bearing steel, raceways are not hardened. Balls - hardened steel. Zinc coating to ISO2081 (excluding raceways). Corrosion resistant coatings on request.

Technical Notes

This is a lower cost slide with non-hardened raceways but still providing high

load capacity.

Temperature range: -30°C to +170°C.

More suited for less frequent opening applications.

Only to be used for horizontal movements.

C_{Orad} is the load rating for a single telescopic slide.

Tips

The fixed top member must be mounted to

the fixed structure and the moving member to the mobile structure - using all of the threaded holes.

The slides have end stops, but these are not designed to stop a moving, loaded slide. External end stops should be used for this.

Order No.	h_1	h_2	h_3	h_4	l_1	l_2 stroke	l_3	l_4	w_1	w_2	r_1	For screws d_1	No. of holes	Load (per rail) C_0 rad N max.	Weight kg
L1992.44-0200	43	20	11,5	11,5	200	210		60	12	6,5	1,5	M5	5	114	0,54
L1992.44-0225	43	20	11,5	11,5	225	235		72,5	12	6,5	1,5	M5	5	130	0,59
L1992.44-0250	43	20	11,5	11,5	250	260		85	12	6,5	1,5	M5	5	144	0,67
L1992.44-0275	43	20	11,5	11,5	275	285		97,5	12	6,5	1,5	M5	5	162	0,74
L1992.44-0300	43	20	11,5	11,5	300	310		110	12	6,5	1,5	M5	5	180	0,81
L1992.44-0325	43	20	11,5	11,5	325	335		122,5	12	6,5	1,5	M5	5	196	0,87
L1992.44-0350	43	20	11,5	11,5	350	360		135	12	6,5	1,5	M5	5	210	0,94
L1992.44-0375	43	20	11,5	11,5	375	385		147,5	12	6,5	1,5	M5	5	226	1,01
L1992.44-0400	43	20	11,5	11,5	400	410		160	12	6,5	1,5	M5	5	246	1,08
L1992.44-0425	43	20	11,5	11,5	425	435		172,5	12	6,5	1,5	M5	5	262	1,14
L1992.44-0450	43	20	11,5	11,5	450	460		185	12	6,5	1,5	M5	7	276	1,21
L1992.44-0500	43	20	11,5	11,5	500	510	110	100	12	6,5	1,5	M5	7	312	1,35
L1992.44-0550	43	20	11,5	11,5	550	560	135	100	12	6,5	1,5	M5	7	342	1,48
L1992.44-0600	43	20	11,5	11,5	600	610	160	100	12	6,5	1,5	M5	7	384	1,62
L1992.44-0650	43	20	11,5	11,5	650	660	185	100	12	6,5	1,5	M5	7	408	1,75
L1992.44-0700	43	20	11,5	11,5	700	710	160	150	12	6,5	1,5	M5	7	444	1,89
L1992.44-0750	43	20	11,5	11,5	750	760	185	150	12	6,5	1,5	M5	7	474	2,02
L1992.44-0800	43	20	11,5	11,5	800	810	210	150	12	6,5	1,5	M5	7	510	2,16
L1992.44-0850	43	20	11,5	11,5	850	860	235	150	12	6,5	1,5	M5	7	540	2,29
L1992.44-0900	43	20	11,5	11,5	900	910	260	150	12	6,5	1,5	M5	7	576	2,43
L1992.44-0950	43	20	11,5	11,5	950	960	285	150	12	6,5	1,5	M5	7	612	2,56
L1992.44-1000	43	20	11,5	11,5	1000	1010	310	150	12	6,5	1,5	M5	7	648	2,70



If you are looking for heavy duty, quality telescopic rails for industrial or commercial applications then these are the rails for you!

The best heavy duty telescopic slides on the market

These are unique rails that are not made from pressed steel but from cold-drawn steel section. The rails can take high loads, with very long strokes, with repeated use, low deflection and minimal play.

TELESCOPIC SLIDES

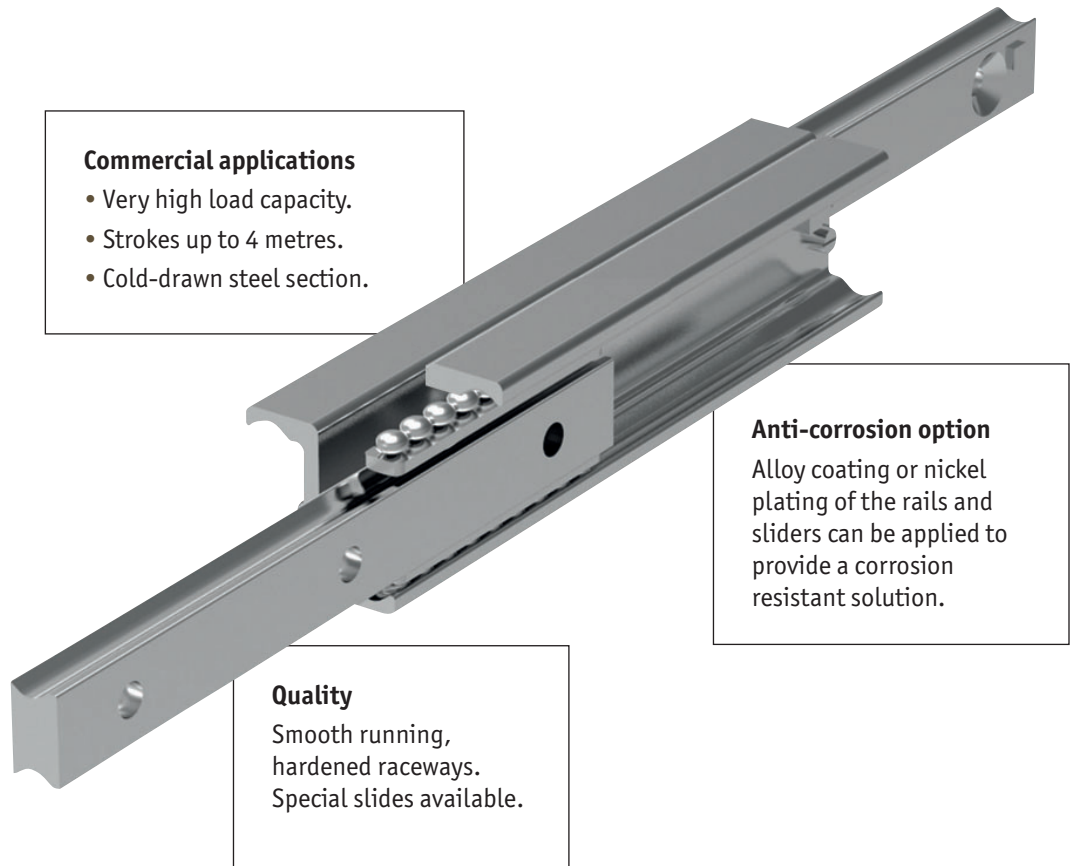

Commercial applications

- Very high load capacity.
- Strokes up to 4 metres.
- Cold-drawn steel section.

Anti-corrosion option

Alloy coating or nickel plating of the rails and sliders can be applied to provide a corrosion resistant solution.

Quality

Smooth running, hardened raceways. Special slides available.

Rail types

Our range of telescopic rails covers partial, full stroke and over-extension.

For more information refer to our product specifications pages or call our technical department.



Partial Stroke (~60%)

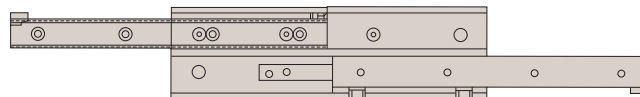

Full Stroke (~100%)

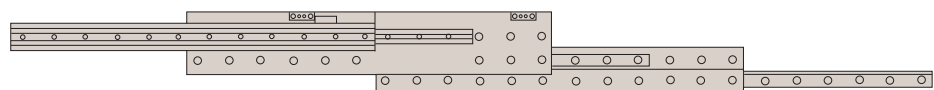

Over-extension (150%)



Telescopic Rail

Specifications and applications

Telescopic Rail

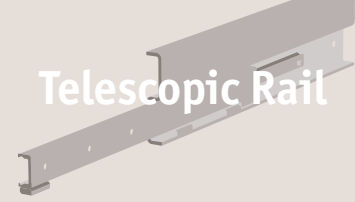

Specifications

- Generally all our telescopic rails have induction hardened raceways.
- Cold drawn roller bearing steel.
- Maximum operating speed 0,8 m/s.
- Temperature range (mainly -30°C to +170°C).
- Electrolytic galvanised to ISO 2081, other anti-corrosion finishes on request.
- High load ratings with low deflection characteristics.
- Minimum play (even at maximum load ratings).
- Smooth, free running movement.
- Long strokes and heavy load ratings.
- Can be used in horizontal applications only (due to the use of a ball cage), with the exception of part number L1985 which uses roller bearings.
- Light duty “cage stops” are included on the telescopic rails to prevent damage to the ball cage. External end stops must be designed into your application (to protect the rails from high forces and possible damage on opening and closing).
- For telescopic rails with an “upper” and “lower” rail, the moving rail should be the lower one. Using the upper rail as the moving element effects the smooth running and the load capacity of the telescopic sliders.
- All load capacity figures are given for a single rail, and based on continuous use.
- Fix to structures using screws of strength class 10,9.
- Anti-corrosion option. We have a highly effective anti-corrosive coating option, and we utilise stainless steel ball bearings in this version.

Applications



Special purpose & packaging machines

Precision positioning systems
handling units
robotic systems • cutting machines



Seating

Sliding seats
disability ramps
seat extensions



Safety guarding

Extending protective systems
sliding gates
automatic pick & place



Logistics solutions

Container extensions
heavy duty extending systems
sliding doors



Disability vehicles

Sliding seats
extension ramps



Transport (naval)

Sliding hatches
pull-out storage



Transport (rail)

Seat adjustment
sliding doors
battery removal units



Transport (automotive)

Ambulance sliding systems
fire fighting vehicles
sliding panels



Transport (military)

Sliding seats
protective hatches
stretcher extensions



L1989 - these are full extension slides made from 316L stainless steel. For use in applications where corrosion may be a problem.



Standard extension	100%
Special extension range	No
Single & double direction?	No
Number of rail sizes	1
Maximum extension (at 100%)	1120 mm
Maximum load (per rail)	35 Kg

Extended stroke telescopic rails

L1997 - these are extended stroke (150%), heavy duty telescopic rails, with high load capacity and stiffness.

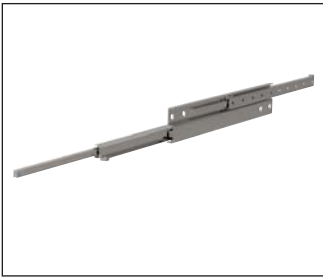

Standard extension	150%
Special extension range	On request
Single & double direction?	No
Number of rail sizes	1
Maximum extension (at 150%)	3030 mm
Maximum load (per rail)	240 Kg

L1998 - these are extended stroke (150%), heavy duty telescopic rails. They have a solid steel intermediate element. They are our heaviest duty extended stroke units.

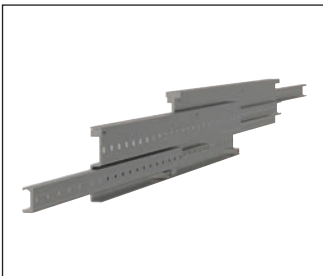

Standard extension	150%
Special extension range	On request
Single & double direction?	No
Number of rail sizes	1
Maximum extension (at 150%)	3020 mm
Maximum load (per rail)	480 Kg

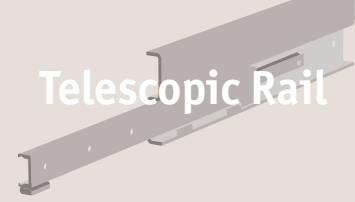

Service life

The service life is defined as the time span between commissioning and the first fatigue or wear indications on the raceway. The service life of a telescopic rail is dependent on several factors, such as the effective load, the installation precision, occurring shocks and vibrations, the operating temperature, the ambient conditions and the lubrication.

Calculation of the service life is based exclusively on the loaded rows of balls.

In practice, the decommissioning of the bearing, due to its destruction or extreme wear of a component, represents the end of service life.

This is taken into account by an application coefficient (f_i), so the service life consists of:

$$L_{Km} = 100 \cdot \left(\frac{\delta}{W} \cdot \frac{1}{f_i} \right)^3$$

L = calculated service life in Km

δ = load capacity factor in N (see tables on following pages)

W = equivalent load in N

f_i = application coefficient

Application coefficient f_i

Operating conditions	Safety factor (f_i)
Neither shocks or vibrations, smooth and low-frequency direction change, clean environment	1,3 - 1,8
Light vibrations and average direction change	1,8 - 2,3
Shocks and vibrations, high-frequency direction change, very dirty environment	2,3 - 3,5

If the external load, P, is the same as the dynamic load capacity, C_{0rad} (which of course must never be exceeded), the service life at ideal operating conditions ($f_i = 1$) is 100Km.

For a single load P, the following applies: $W = P$.

If several external loads occur simultaneously, the equivalent load is calculated as follows:

$$W = P_{rad} + \left(\frac{P_{ax}}{C_{0ax}} + \frac{M_1}{M_x} + \frac{M_2}{M_y} + \frac{M_3}{M_z} \right) \cdot C_{0rad}$$