

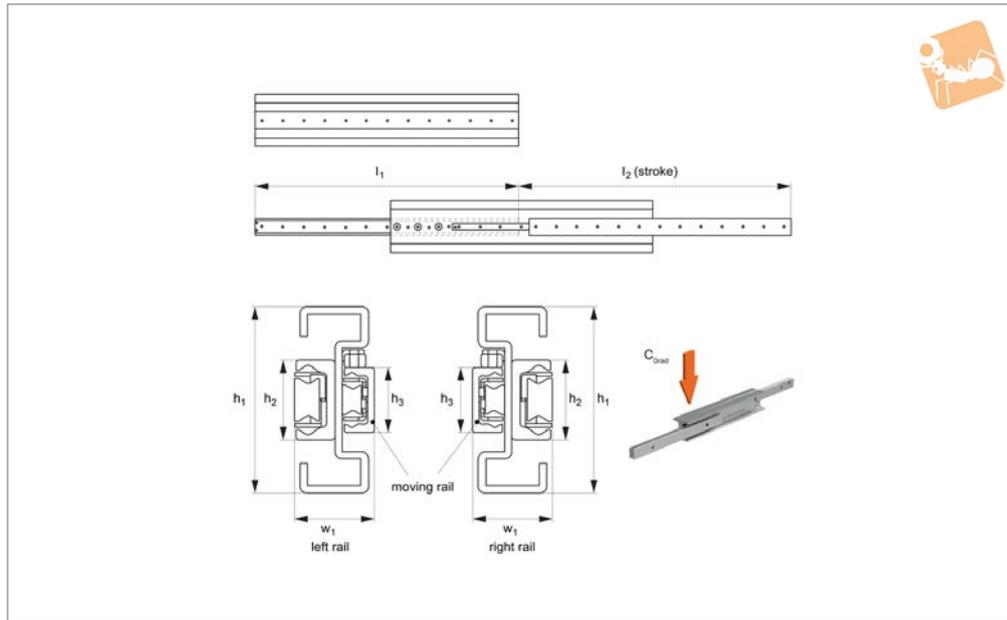

# Fully Telescopic Slides

ultra heavy-duty



**L1995**

TELESCOPIC SLIDES

### Material

Cold drawn bearing steel, raceways hardened to 60 HRC. Balls - hardened steel.

Zinc coating to ISO 2081 (excluding raceways). Corrosion resistant coatings available on request.

### Technical Notes

These are ultra heavy load capacity. They

can support heavy loads with continuous movements 24 hours per day, 7 days a week - even with vibration and high stroke frequency.

Optimal balance between high performance and light-weight.

$C_{0rad}$  is the load rating for a single telescopic slide.

Moving rail must be lower rail (unless tech-

nical department consulted).

### Tips

Moving element smaller than the fixed one.

These are handed rails - ie left and right hands to be specified.

Order No.	Type	$l_1$	$l_2$ stroke	$h_1$	$h_2$	$h_3$	$w_1$	Load (per rail) $C_{0rad}$ N max.
L1995.43-0530R	Right	530	552	100	43	35	43	2389
L1995.43-0610R	Right	610	620	100	43	35	43	2960
L1995.43-0690R	Right	690	726	100	43	35	43	3091
L1995.43-0770R	Right	770	793	100	43	35	43	3662
L1995.43-0850R	Right	850	860	100	43	35	43	4242
L1995.43-0930R	Right	930	966	100	43	35	43	4365
L1995.43-1010R	Right	1010	1033	100	43	35	43	4942
L1995.43-1090R	Right	1090	1100	100	43	35	43	5524
L1995.43-1170R	Right	1170	1206	100	43	35	43	5144
L1995.43-1250R	Right	1250	1273	100	43	35	43	4930
L1995.43-1330R	Right	1330	1379	100	43	35	43	4474
L1995.43-1440R	Right	1446	1446	100	43	35	43	4311
L1995.43-1490R	Right	1490	1513	100	43	35	43	4159
L1995.43-1570R	Right	1570	1607	100	43	35	43	4886
L1995.43-1650R	Right	1650	1686	100	43	35	43	3710
L1995.43-1730R	Right	1730	1753	100	43	35	43	3597
L1995.43-1810R	Right	1810	1847	100	43	35	43	3391
L1995.43-1890R	Right	1890	1926	100	43	35	43	3256
L1995.43-1970R	Right	1790	2020	100	43	35	43	3086
L1995.43-0530L	Left	530	552	100	43	35	43	2389
L1995.43-0610L	Left	610	620	100	43	35	43	2960
L1995.43-0690L	Left	690	726	100	43	35	43	3091
L1995.43-0770L	Left	770	793	100	43	35	43	3662
L1995.43-0850L	Left	850	860	100	43	35	43	4242
L1995.43-0930L	Left	930	966	100	43	35	43	4365
L1995.43-1010L	Left	1010	1033	100	43	35	43	4942
L1995.43-1090L	Left	1090	1100	100	43	35	43	5524



Order No.	Type	$l_1$	$l_2$ stroke	$h_1$	$h_2$	$h_3$	$w_1$	Load (per rail) $C_{0 \text{ rad}}$ N max.
<b>L1995.43-1170L</b>	Left	1170	1206	100	43	35	43	5144
<b>L1995.43-1250L</b>	Left	1250	1273	100	43	35	43	4930
<b>L1995.43-1330L</b>	Left	1330	1379	100	43	35	43	4474
<b>L1995.43-1440L</b>	Left	1446	1446	100	43	35	43	4311
<b>L1995.43-1490L</b>	Left	1490	1513	100	43	35	43	4159
<b>L1995.43-1570L</b>	Left	1570	1607	100	43	35	43	4886
<b>L1995.43-1650L</b>	Left	1650	1686	100	43	35	43	3710
<b>L1995.43-1730L</b>	Left	1730	1753	100	43	35	43	3597
<b>L1995.43-1810L</b>	Left	1810	1847	100	43	35	43	3391
<b>L1995.43-1890L</b>	Left	1890	1926	100	43	35	43	3256
<b>L1995.43-1970L</b>	Left	1790	2020	100	43	35	43	3086

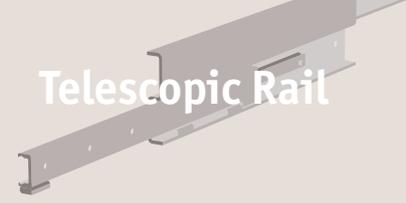

If you are looking for heavy duty, quality telescopic rails for industrial or commercial applications then these are the rails for you!

### The best heavy duty telescopic slides on the market

These are unique rails that are not made from pressed steel but from cold-drawn steel section. The rails can take high loads, with very long strokes, with repeated use, low deflection and minimal play.

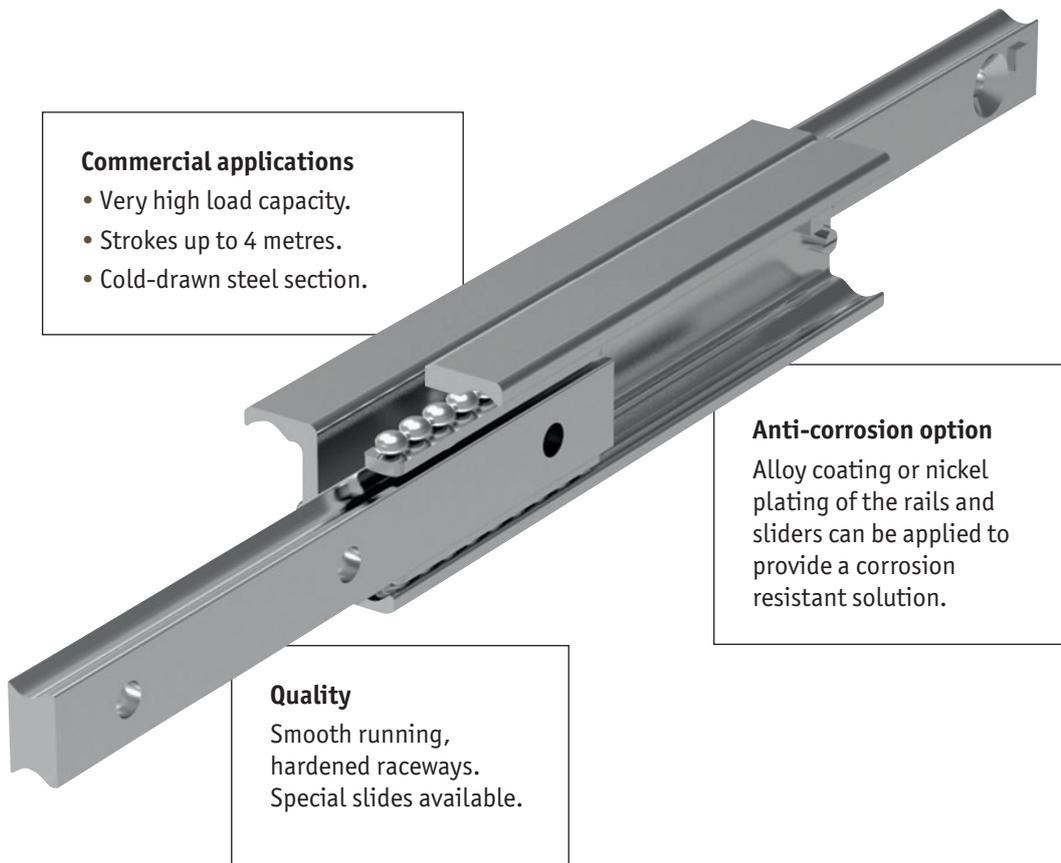

**Commercial applications**

- Very high load capacity.
- Strokes up to 4 metres.
- Cold-drawn steel section.

**Anti-corrosion option**  
Alloy coating or nickel plating of the rails and sliders can be applied to provide a corrosion resistant solution.

**Quality**  
Smooth running, hardened raceways. Special slides available.



Partial Stroke (~60%)

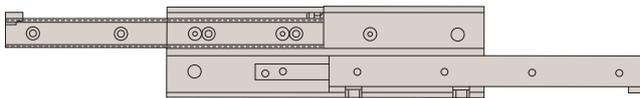

Full Stroke (~100%)

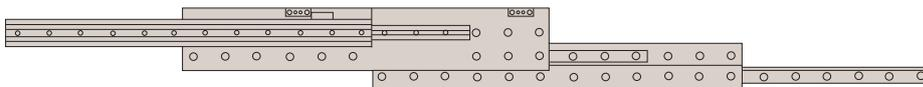

Over-extension (150%)

### Rail types

Our range of telescopic rails covers partial, full stroke and over-extension.

For more information refer to our product specifications pages or call our technical department.



### Specifications

- Generally all our telescopic rails have induction hardened raceways.
- Cold drawn roller bearing steel.
- Maximum operating speed 0,8 m/s.
- Temperature range (mainly -30°C to +170°C).
- Electrolytic galvanised to ISO 2081, other anti-corrosion finishes on request.
- High load ratings with low deflection characteristics.
- Minimum play (even at maximum load ratings).
- Smooth, free running movement.
- Long strokes and heavy load ratings.
- Can be used in horizontal applications only (due to the use of a ball cage), with the exception of part number L1985 which uses roller bearings.
- Light duty “cage stops” are included on the telescopic rails to prevent damage to the ball cage. External end stops must be designed into your application (to protect the rails from high forces and possible damage on opening and closing).
- For telescopic rails with an “upper” and “lower” rail, the moving rail should be the lower one. Using the upper rail as the moving element effects the smooth running and the load capacity of the telescopic sliders.
- All load capacity figures are given for a single rail, and based on continuous use.
- Fix to structures using screws of strength class 10,9.
- Anti-corrosion option. We have a highly effective anti-corrosive coating option, and we utilise stainless steel ball bearings in this version.

### Applications



#### Special purpose & packaging machines

Precision positioning systems  
handling units  
robotic systems • cutting machines



#### Seating

Sliding seats  
disability ramps  
seat extensions



#### Safety guarding

Extending protective systems  
sliding gates  
automatic pick & place



#### Logistics solutions

Container extensions  
heavy duty extending systems  
sliding doors



#### Disability vehicles

Sliding seats  
extension ramps



#### Transport (naval)

Sliding hatches  
pull-out storage



#### Transport (rail)

Seat adjustment  
sliding doors  
battery removal units



#### Transport (automotive)

Ambulance sliding systems  
fire fighting vehicles  
sliding panels



#### Transport (military)

Sliding seats  
protective hatches  
stretcher extensions

**L1989** - these are full extension slides made from 316L stainless steel. For use in applications where corrosion may be a problem.

Standard extension	100%
Special extension range	No
Single & double direction?	No
Number of rail sizes	1
Maximum extension (at 100%)	1120 mm
Maximum load (per rail)	35 Kg



### Extended stroke telescopic rails

**L1997** - these are extended stroke (150%), heavy duty telescopic rails, with high load capacity and stiffness.

Standard extension	150%
Special extension range	On request
Single & double direction?	No
Number of rail sizes	1
Maximum extension (at 150%)	3030 mm
Maximum load (per rail)	240 Kg



**L1998** - these are extended stroke (150%), heavy duty telescopic rails. They have a solid steel intermediate element. They are our heaviest duty extended stroke units.

Standard extension	150%
Special extension range	On request
Single & double direction?	No
Number of rail sizes	1
Maximum extension (at 150%)	3020 mm
Maximum load (per rail)	480 Kg

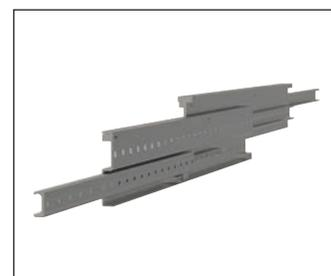



### Service life

The service life is defined as the time span between commissioning and the first fatigue or wear indications on the raceway. The service life of a telescopic rail is dependent on several factors, such as the effective load, the installation precision, occurring shocks and vibrations, the operating temperature, the ambient conditions and the lubrication.

Calculation of the service life is based exclusively on the loaded rows of balls.

In practice, the decommissioning of the bearing, due to its destruction or extreme wear of a component, represents the end of service life.

This is taken into account by an application coefficient ( $f_i$ ), so the service life consists of:

$$L_{Km} = 100 \cdot \left( \frac{\delta}{W} \cdot \frac{1}{f_i} \right)^3$$

$L$  = calculated service life in Km

$\delta$  = load capacity factor in N (see tables on following pages)

$W$  = equivalent load in N

$f_i$  = application coefficient

### Application coefficient $f_i$

Operating conditions	Safety factor ( $f_i$ )
Neither shocks or vibrations, smooth and low-frequency direction change, clean environment	1,3 - 1,8
Light vibrations and average direction change	1,8 - 2,3
Shocks and vibrations, high-frequency direction change, very dirty environment	2,3 - 3,5

If the external load,  $P$ , is the same as the dynamic load capacity,  $C_{0rad}$  (which of course must never be exceeded), the service life at ideal operating conditions ( $f_i = 1$ ) is 100Km.

For a single load  $P$ , the following applies:  $W = P$ .

If several external loads occur simultaneously, the equivalent load is calculated as follows:

$$W = P_{rad} + \left( \frac{P_{ax}}{C_{0ax}} + \frac{M_1}{M_x} + \frac{M_2}{M_y} + \frac{M_3}{M_z} \right) \cdot C_{0rad}$$