

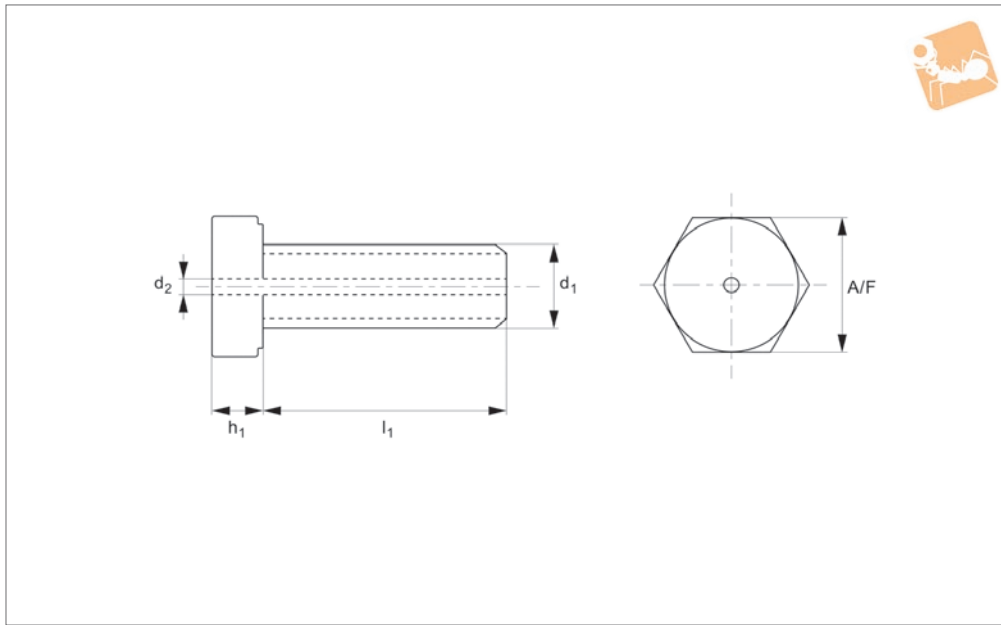

Vented Screws - Hex. Head

304 stainless

Vented Screws



P0091.A2

VENTED SCREWS

Material

Stainless steel (AISI 304, 1.4301), strength class 60.
Ultrasonically cleaned.

Technical Notes

To DIN 933 (with central vent). Other sizes

available on request.

Tips

These products help eliminate virtual leaks from high vacuum (HV and UHV) systems, thereby improving pump-down times. Trapped gases at the bottom of a tapped

hole are able to escape via the central vent down the middle of the screw.

Order No.	l_1	d_1	d_2	h_1	A/F
P0091.030-005-A2	5	M 3	1.0	2.0	6
P0091.030-006-A2	6	M 3	1.0	2.0	6
P0091.030-008-A2	8	M 3	1.0	2.0	6
P0091.030-010-A2	10	M 3	1.0	2.0	6
P0091.030-012-A2	12	M 3	1.0	2.0	6
P0091.030-016-A2	16	M 3	1.0	2.0	6
P0091.040-005-A2	5	M 4	1.0	2.8	7
P0091.040-006-A2	6	M 4	1.0	2.8	7
P0091.040-008-A2	8	M 4	1.0	2.8	7
P0091.040-010-A2	10	M 4	1.0	2.8	7
P0091.040-012-A2	12	M 4	1.0	2.8	7
P0091.040-016-A2	16	M 4	1.0	2.8	7
P0091.040-020-A2	20	M 4	1.0	2.8	7
P0091.040-025-A2	25	M 4	1.0	2.8	7
P0091.040-030-A2	30	M 4	1.0	2.8	7
P0091.040-035-A2	35	M 4	1.0	2.8	7
P0091.050-006-A2	6	M 5	1.3	3.5	8
P0091.050-008-A2	8	M 5	1.3	3.5	8
P0091.050-010-A2	10	M 5	1.3	3.5	8
P0091.050-012-A2	12	M 5	1.3	3.5	8
P0091.050-016-A2	16	M 5	1.3	3.5	8
P0091.050-020-A2	20	M 5	1.3	3.5	8
P0091.050-025-A2	25	M 5	1.3	3.5	8
P0091.050-030-A2	30	M 5	1.3	3.5	8
P0091.050-035-A2	35	M 5	1.3	3.5	8
P0091.050-040-A2	40	M 5	1.3	3.5	8
P0091.060-008-A2	8	M 6	1.6	4.0	10
P0091.060-010-A2	10	M 6	1.6	4.0	10
P0091.060-012-A2	12	M 6	1.6	4.0	10
P0091.060-016-A2	16	M 6	1.6	4.0	10
P0091.060-020-A2	20	M 6	1.6	4.0	10
P0091.060-025-A2	25	M 6	1.6	4.0	10



VENTED SCREWS

Order No.	l ₁	d ₁	d ₂	h ₁	A/F
P0091.060-030-A2	30	M 6	1.6	4.0	10
P0091.060-035-A2	35	M 6	1.6	4.0	10
P0091.060-040-A2	40	M 6	1.6	4.0	10
P0091.060-045-A2	45	M 6	1.6	4.0	10
P0091.060-050-A2	50	M 6	1.6	4.0	10
P0091.080-012-A2	12	M 8	1.8	5.3	13
P0091.080-016-A2	16	M 8	1.8	5.3	13
P0091.080-020-A2	20	M 8	1.8	5.3	13
P0091.080-025-A2	25	M 8	1.8	5.3	13
P0091.080-030-A2	30	M 8	1.8	5.3	13
P0091.080-035-A2	35	M 8	1.8	5.3	13
P0091.080-040-A2	40	M 8	1.8	5.3	13
P0091.080-045-A2	45	M 8	1.8	5.3	13
P0091.080-050-A2	50	M 8	1.8	5.3	13
P0091.080-055-A2	55	M 8	1.8	5.3	13
P0091.100-016-A2	16	M10	1.8	6.4	17
P0091.100-020-A2	20	M10	1.8	6.4	17
P0091.100-025-A2	25	M10	1.8	6.4	17
P0091.100-030-A2	30	M10	1.8	6.4	17
P0091.100-035-A2	35	M10	1.8	6.4	17
P0091.100-040-A2	40	M10	1.8	6.4	17
P0091.100-045-A2	45	M10	1.8	6.4	17
P0091.100-050-A2	50	M10	1.8	6.4	17
P0091.100-055-A2	55	M10	1.8	6.4	17
P0091.100-060-A2	60	M10	1.8	6.4	17
P0091.120-020-A2	20	M12	1.8	7.5	19
P0091.120-025-A2	25	M12	1.8	7.5	19
P0091.120-030-A2	30	M12	1.8	7.5	19
P0091.120-035-A2	35	M12	1.8	7.5	19
P0091.120-040-A2	40	M12	1.8	7.5	19
P0091.120-045-A2	45	M12	1.8	7.5	19
P0091.120-050-A2	50	M12	1.8	7.5	19
P0091.120-060-A2	60	M12	1.8	7.5	19
P0091.160-025-A2	25	M16	1.8	10.0	24
P0091.160-030-A2	30	M16	1.8	10.0	24
P0091.160-035-A2	35	M16	1.8	10.0	24
P0091.160-040-A2	40	M16	1.8	10.0	24
P0091.160-045-A2	45	M16	1.8	10.0	24
P0091.160-050-A2	50	M16	1.8	10.0	24
P0091.160-060-A2	60	M16	1.8	10.0	24



VENTED SCREWS



Vented screws are used to remove trapped gases (at the bottom of blind threads) in HV (high vacuum) and UHV (ultra-high vacuum) systems. They are precision cleaned.

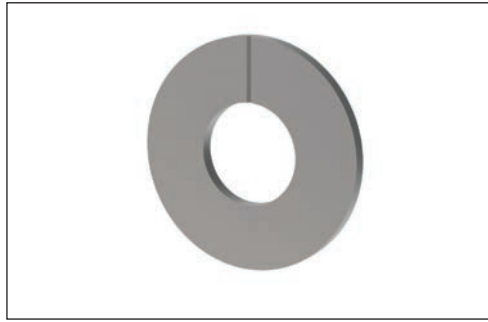

They are at their most effective when used with vented washers.

Finishing Options



Silver plating



Gold plating



Nickel plating



Molybdenum coating



Tungsten coating

Typical Applications

- Semi-conductor industry (wafers & microelectronics in UHV)
- Clean rooms (ultra clean assembly processes)
- Energy/Solar energy (photovoltaic panel production)
- Vacuum applications (helping to seal vacuums effectively)
- R&D

Virtual Leaks

A blind tapped hole inside a vacuum system leaves residual air space at the bottom that cannot be fully evacuated in the vacuum cycle when a bolt, screw, or other fastener is threaded into the hole. The screw itself is a helix with a large surface area also containing voids of trapped air. This produces virtual leaks. Vented screws and fasteners ensure direct ventilation of these voids, allowing the trapped volumes of air within the threads and at the bottoms of the holes to be fully evacuated. This speeds pump-down and helps improve system performance.

Galling

In High Vacuum and Ultra High Vacuum systems, like materials can become cold-fused together (called galling) due to thermal expansion and the lack of moisture created by the vacuum. Screws threaded into blind tapped holes are commonly affected in this way, and components made of stainless steel are particularly susceptible. Finishes, coatings, and platings are uniquely formulated to prevent galling, making parts maintenance and replacement faster and easier. Without the hassle of galled, stuck fasteners, downtime is minimized.

Vacuum Contamination

Our vented and coated fasteners are inspected, cleaned, and packaged in a Class 100 cleanroom environment therefore particulate and organic surface contamination is significantly reduced or eliminated altogether.

