

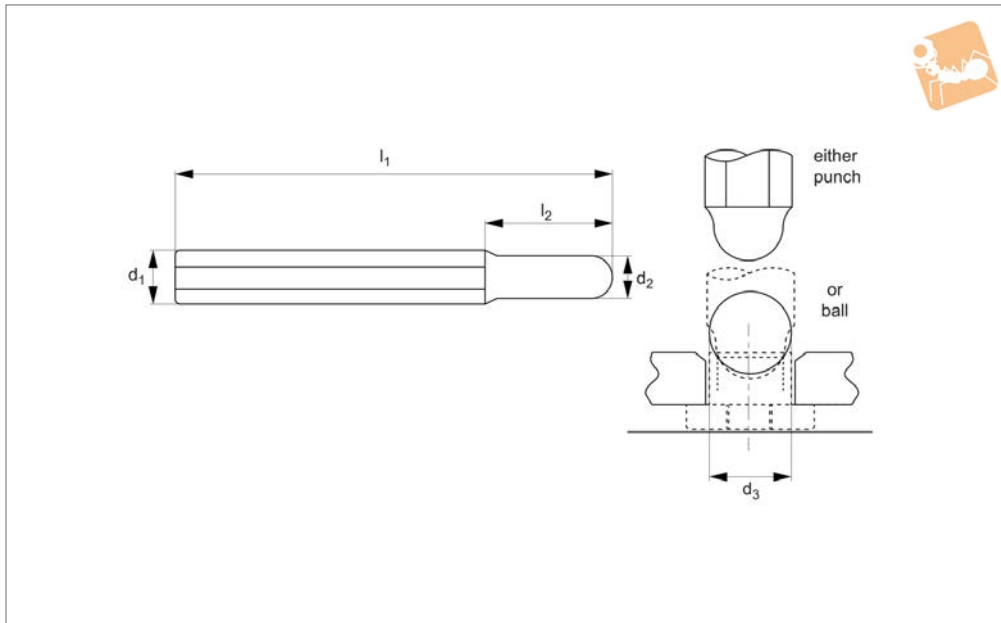

# Installation Tools for retainer flanges

## Captive Screws



**P0169.TL**

CAPTIVE SCREWS

### Material

Ball bearings and punches from steel.  
For small quantity installation we suggest you install the flanges using the ball bearings,  
for large quantities it is easier to purchase the retaining flange punch.

### Technical Notes

Select the retainer flange to suit thread of the captive screw and the thickness of the panel to be retained.  
Drill and countersink hole in the panel and use the ball bearing supplied to spread the flange into the countersunk hole.

The captive screw is then screwed into the flange and the screw is retained to the panel.

### Tips

Mounting hole diameter to H9 clearance.

Order No.	Type	For flange size	d <sub>1</sub>	d <sub>2</sub>	l <sub>1</sub>	d <sub>3</sub>	l <sub>2</sub>
P0169.030-BL	Ball bearing	P0169.030	-	-	-	5	-
P0169.040-BL	Ball bearing	P0169.040	-	-	-	7	-
P0169.050-BL	Ball bearing	P0169.050	-	-	-	8	-
P0169.060-BL	Ball bearing	P0169.060	-	-	-	10	-
P0169.080-BL	Ball bearing	P0169.080	-	-	-	13	-
P0169.030-PN	Punch	P0169.030	10.0	5	100	-	30
P0169.040-PN	Punch	P0169.040	11.5	7	100	-	30
P0169.050-PN	Punch	P0169.050	13.0	8	100	-	30
P0169.060-PN	Punch	P0169.060	16.0	10	100	-	30
P0169.080-PN	Punch	P0169.080	19.0	13	100	-	30



Automotion produce a wide range of fasteners designed for application where it is important that fasteners are not separated from equipment (e.g. cover panels etc). This is now important to ensure that equipment complies with Machinery Directive 200642/EC - requiring that fasteners remain attached to fixed guards or equipment when guards are removed.





Our captive panel screws are manufactured mainly from stainless steel (A2, AISI 303 grade), but they can also be produced in stainless steel (A4, AISI 316), aluminium, brass or zinc-plated steel.

Many finishes can be applied - black-oxide finish, anodizing etc.

The main options are as follows:

Finish	Notes
<b>Black Chrome (MIL-C-1458B)</b>	Black chrome is a hard, non-reflective coating which is resistant to abrasion, heat and corrosion. The black chrome surface is a dull, dark grey and may be waxed or oiled to darken surface.
<b>Black Oxide Coating (MIL-C-13924B)</b>	Black oxide is a uniform black coating for ferrous metals. Generally it is considered a decorative coating and provides only very limited corrosion protection under mild corrosion conditions.
<b>Cadmium</b>	Cadmium is a bright, silvery white plating. Supplementary treatments for Type II can be golden, iridescent, amber, black or olive drab.
<b>Passivate (QQ-P-35/MIL S-5005C)</b>	Passivation is a process designed to remove foreign metals from the surface of stainless and corrosion resistant steels.
<b>Phosphate Coating Light (TT-C-00490B)</b>	Phosphate coating is a light coating for use as a base paint.
<b>Gold (MIL-G-45204B)</b>	Yellow to orange colour depending on proprietary process used. Will range from matt to bright finish depending on base metal. Good corrosion resistance and high tarnish resistance.
<b>Nickel (QQ-N-290A)</b>	Nickel is a corrosion protective plating for steel, zinc and zinc alloys as well as copper and copper alloys.
<b>Zinc (QQ-Z-325C)</b>	The primary use of chromate finishes on zinc is to retard or prevent formation of white corrosion products on zinc surfaces.

The available head sockets include:

Schematic	Drive Types	Uses
	Hexagonal Recess	Ideal for precision assembly. Most recommended where less surface area is available.
	Crosshead (Phillips®)	Provides good control in driving. Always use a driver bit of the proper size which is in good condition.
	Star Head (Torx®)	Positive-engaging, fast-locating method which transmits drive torque with less required downward pressure. Good fastening appearance.
	Slotted	Accepts standard blade screwdriver. Requires less downward pressure to drive parts than those with recessed openings. Use a proper fitting blade to minimize slippage.
	Security	These screws are impossible to remove without the special matching screw driver.



Automation provides a wide range of captive screws to aid customers to comply with the Machinery Directive 2006/42/EC.

In general there is a requirement that fixings for fixed guards shall remain attached to the guard or machinery when the guard is removed. This was implemented mainly to ensure that as far as possible fasteners are not lost when the guard is removed and the guard is therefore re-installed with all required fixings.

A wide range of captive screws and thumb screws are provided...



**P0151**  
Button Head - Hex  
Security and Torx Options



**P0154**  
Socket Head - Cap Screw  
Security and Torx Options



**P0158**  
Hexagon Head Bolt



**P0159**  
Captive Panel Screw



**P0160**  
Thin Head Thumb Screws



**P0161**  
Thumb Screws

### Installation

To work effectively the captive screw when installed needs to have a space or counterbore between the thread and cover at least equal to the length of the thread.

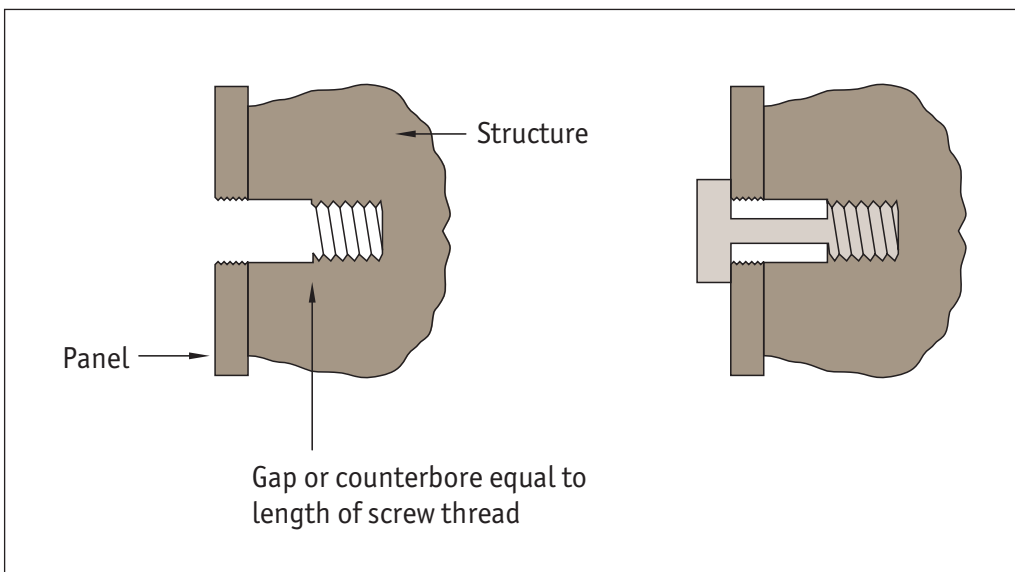

Captive Screws from Automation Components

CAPTIVE SCREWS



Other options to retain screws to panels are either our retaining washers or our retaining flanges.

#### Retaining washers

These are simple but effective when used with our captive screws. The captive screws have a normal thread then a reduced diameter for the rest of the screw length.

The washer has a small length of thread on the internal diameter and once screwed on to the captive screw is effectively captive.

#### Example

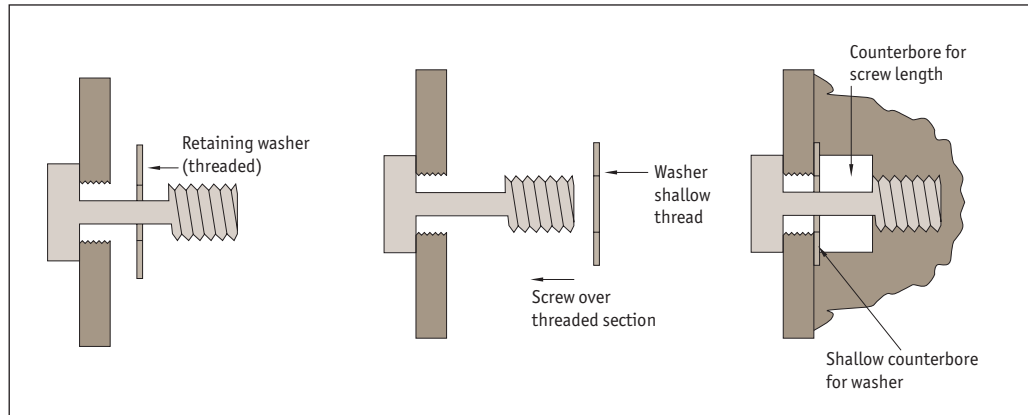

Screw the thin retaining washer onto the captive screw and the screw is therefore retained to the panel.

