

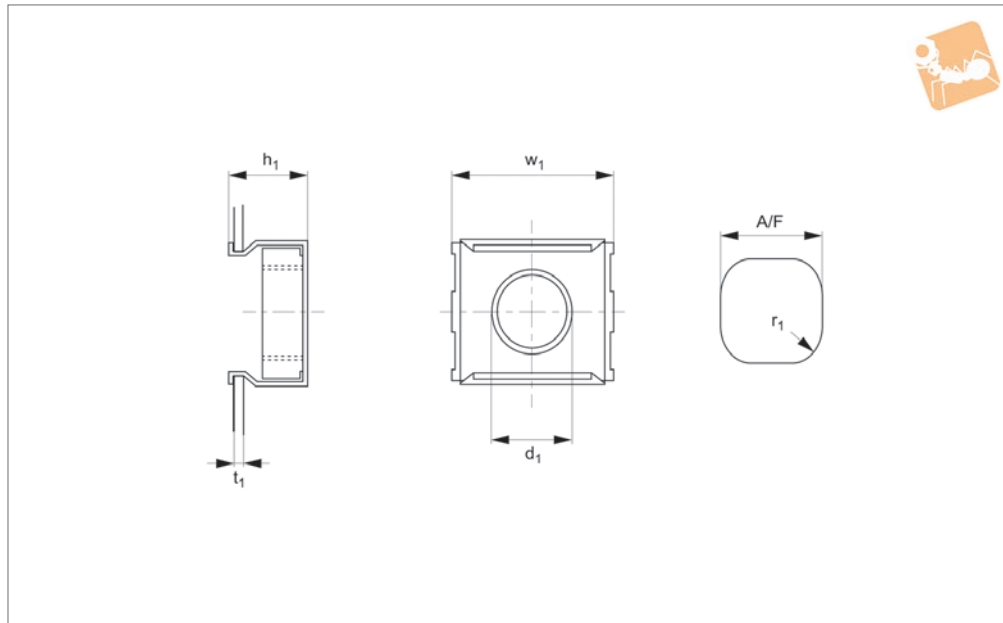

Cage Nuts

Cage nuts - A2 stainless



P0325.A2

NUTS

Material

Stainless steel (A2, AISI 303).

$r = 0,5$. Select the part number according to the thread required and the thickness of the preferred material.

Technical Notes

A/F is hole size across flats.

Order No.	For panel t_1	d_1	w_1 $\pm 0,5$	A/F	h_1 $\pm 0,3$
P0325.040-016-A2	0,7-1,6	M 4	13,2	9,5	8,5
P0325.040-026-A2	1,7-2,6	M 4	13,2	9,5	9,5
P0325.040-035-A2	2,7-3,5	M 4	13,2	9,5	10,5
P0325.050-016-A2	0,7-1,6	M 5	13,2	9,5	8,5
P0325.050-026-A2	1,7-2,6	M 5	13,2	9,5	9,5
P0325.050-035-A2	2,7-3,5	M 5	13,2	9,5	10,5
P0325.060-016-A2	0,7-1,6	M 6	13,2	9,5	8,5
P0325.060-026-A2	1,7-2,6	M 6	13,2	9,5	9,5
P0325.060-035-A2	2,7-3,5	M 6	13,2	9,5	10,5
P0325.080-017-A2	0,7-1,7	M 8	16,5	12,8	10,5
P0325.080-031-A2	1,8-3,1	M 8	16,5	12,8	12,0
P0325.080-043-A2	3,2-4,3	M 8	16,5	12,8	13,5
P0325.100-017-A2	0,7-1,7	M10	16,5	12,8	10,5
P0325.100-031-A2	1,8-3,1	M10	16,5	12,8	12,0
P0325.100-043-A2	3,2-4,3	M10	16,5	12,8	13,5