

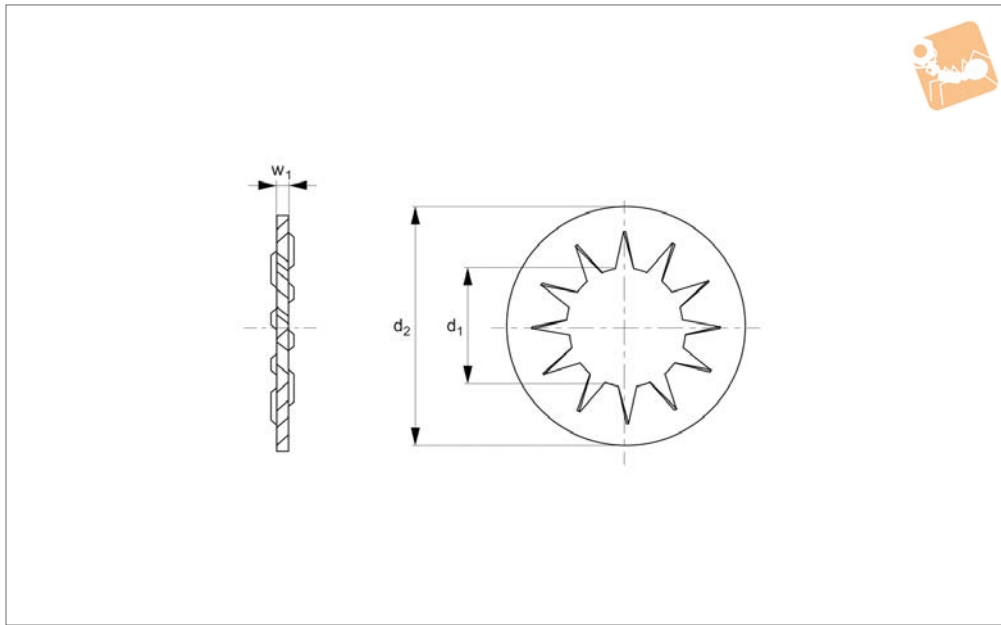

Internal Serrated Lock Washers

Steel, zinc-plated



P0373.ZP

FLAT WASHERS

Material
Spring steel, zinc-plated.

Technical Notes
To DIN 6798 B.

Order No.	d ₁ for thread	d ₂	w ₁	Material
P0373.020-ZP	M 2	4.5	0.3	Steel ZP
P0373.025-ZP	M2,5	5.5	0.4	Steel ZP
P0373.030-ZP	M 3	6.0	0.4	Steel ZP
P0373.035-ZP	M3,5	7.0	0.5	Steel ZP
P0373.040-ZP	M 4	8.0	0.5	Steel ZP
P0373.050-ZP	M 5	10.0	0.6	Steel ZP
P0373.060-ZP	M 6	11.0	0.7	Steel ZP
P0373.070-ZP	M 7	12.5	0.8	Steel ZP
P0373.080-ZP	M 8	15.0	0.8	Steel ZP
P0373.100-ZP	M10	18.0	0.9	Steel ZP
P0373.120-ZP	M12	20.5	1.0	Steel ZP
P0373.140-ZP	M14	24.0	1.0	Steel ZP
P0373.160-ZP	M16	26.0	1.2	Steel ZP
P0373.180-ZP	M18	30.0	1.4	Steel ZP
P0373.200-ZP	M20	33.0	1.4	Steel ZP
P0373.220-ZP	M22	36.0	1.5	Steel ZP
P0373.240-ZP	M24	38.0	1.5	Steel ZP