

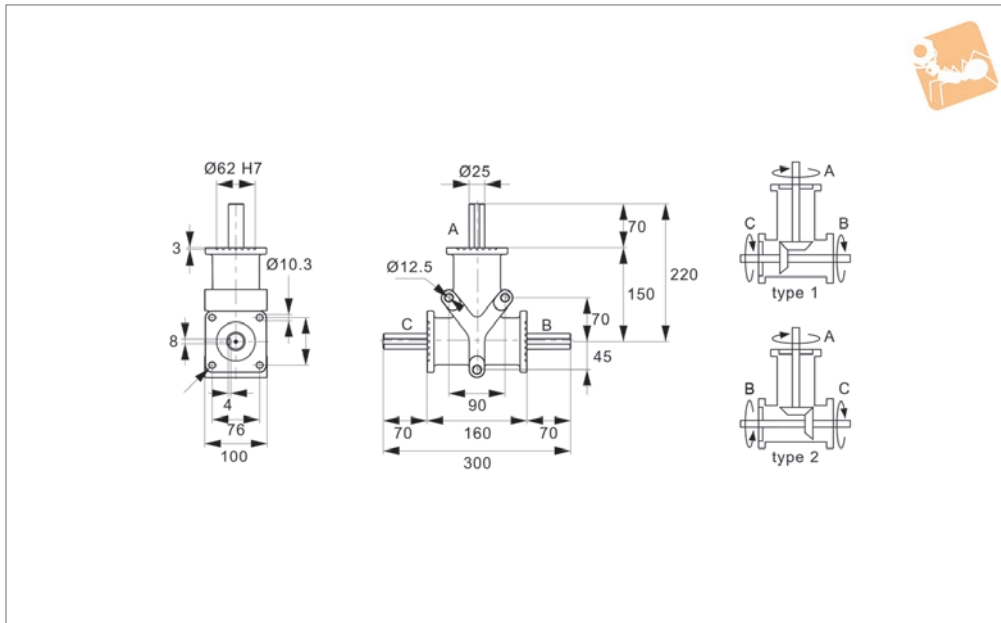

Stainless Right Angle Drives - 3 Shafts

Ø25 shafts

Right Angle Gear Boxes



R2359

RIGHT ANGLE GEAR BOXES

Material

Stainless steel (AISI 316) housing and shafts, seals - NBR. Spiral bevel gears from hardened steel.

Technical Notes

Normally used as speed reducers.
Max. radial loading 400N. Max. axial loading 160N.

Angular alignment: 15' to 30' of arc.

Order No.	Shaft dia.	Ratio	Input shaft A kW max.	Output shaft B Nm max.	Output shaft C Nm max.	Weight kg
R2359.1	25	1	4.55	15.50	15.50	9.45
R2359.2	25	2	3.37	11.50	11.50	9.45