

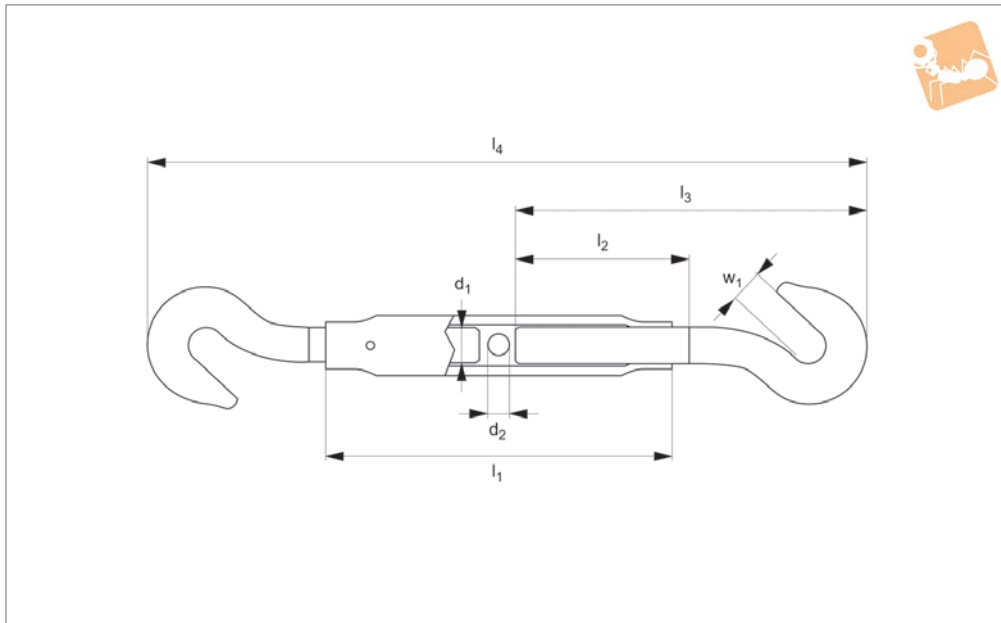

Hook End Pipe Body Turnbuckles

steel

Turnbuckles

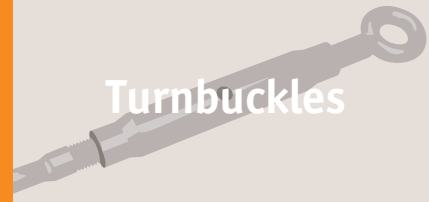

R3816

TURNBUCKLES

Material

Steel (1.0037 up to M48 then 1.0052), zinc-plated.

Hot dip galvanized body, available on request providing increased protection against corrosion. Please add -FZ for hot dip galvanized, e.g. R3804.006-FZ.

Technical Notes

To DIN 1478.

Tips

Turnbuckles consist of a metal frame with right hand thread one end and left hand thread the other end. Used for tensioning

by rotating turnbuckle body without twisting attached rope or cable.

Important Notes

Turnbuckles are not to be used for lifting. Only suitable for use in tension.

Order No.	d ₁	l ₁	d ₂	l ₂	l ₃	l ₄ min.	l ₄ max.	w ₁	Weight kg
R3816.006-ZP	M 6	110	6	50	77.0	160	250	9.5	0.16
R3816.008-ZP	M 8	110	8	60	98.0	204	289	11.0	0.20
R3816.010-ZP	M10	125	8	73	116.5	241	336	14.0	0.30
R3816.012-ZP	M12	125	10	90	146.0	303	393	18.0	0.47
R3816.016-ZP	M16	170	10	100	165.0	340	460	19.0	1.01
R3816.020-ZP	M20	200	12	105	180.0	372	512	21.0	1.40
R3816.024-ZP	M24	255	12	135	225.0	463	543	29.0	2.86
R3816.030-ZP	M30	255	16	140	225.0	527	687	31.0	4.09
R3816.036-ZP	M36	295	16	170	300.0	617	697	35.0	6.85