

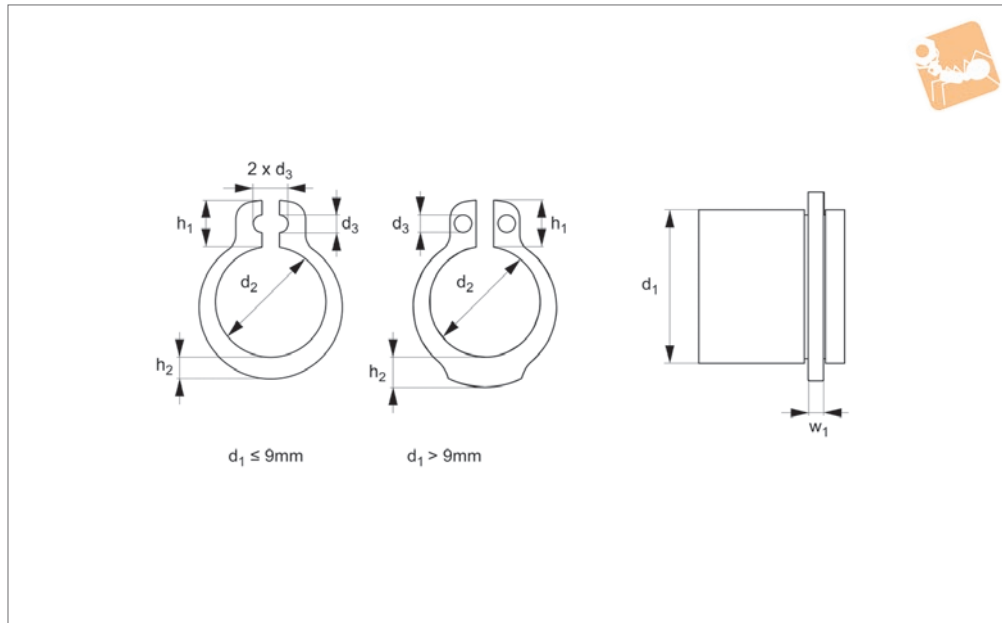

External PH Circlips

Steel phosphated

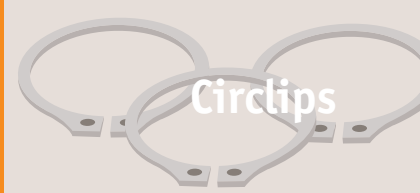

P0380.PH

CIRCLIPS

Material

Steel, phosphated.

Technical Notes

To DIN 471.

Order No.	d_1	d_2	d_3 min.	h_1 max.	h_2	w_1	Material
P0380.003-PH	3	2.7	1.0	1.9	0.8	0.40	Steel PH
P0380.004-PH	4	3.7	1.0	2.2	0.9	0.40	Steel PH
P0380.005-PH	5	3.7	1.0	2.5	1.1	0.60	Steel PH
P0380.006-PH	6	5.6	1.2	2.7	1.3	0.70	Steel PH
P0380.007-PH	7	6.5	1.2	3.1	1.4	0.80	Steel PH
P0380.008-PH	8	7.4	1.2	3.2	1.5	0.80	Steel PH
P0380.009-PH	9	8.4	1.2	3.3	1.7	1.00	Steel PH
P0380.010-PH	10	9.3	1.5	3.3	1.8	1.00	Steel PH
P0380.011-PH	11	10.2	1.5	3.3	1.8	1.00	Steel PH
P0380.012-PH	12	11.0	1.7	3.3	1.8	1.00	Steel PH
P0380.013-PH	13	11.9	1.7	3.4	2.0	1.00	Steel PH
P0380.014-PH	14	12.9	1.7	3.5	2.1	1.00	Steel PH
P0380.015-PH	15	13.8	1.7	3.6	0.8	1.00	Steel PH
P0380.016-PH	16	14.7	1.7	3.7	2.2	1.00	Steel PH
P0380.017-PH	17	15.7	1.7	3.8	2.3	1.00	Steel PH
P0380.018-PH	18	16.5	2.0	3.9	2.4	1.20	Steel PH
P0380.019-PH	19	17.5	2.0	3.9	2.5	1.20	Steel PH
P0380.020-PH	20	18.5	2.0	4.0	2.6	1.20	Steel PH
P0380.022-PH	22	20.5	2.0	4.2	2.8	1.20	Steel PH
P0380.023-PH	23	21.4	2.0	4.3	2.9	1.20	Steel PH
P0380.024-PH	24	22.2	2.0	4.4	3.0	1.20	Steel PH
P0380.025-PH	25	23.2	2.0	4.4	3.0	1.20	Steel PH
P0380.026-PH	26	24.2	2.0	4.5	3.1	1.20	Steel PH
P0380.027-PH	27	25.1	2.0	4.6	3.1	1.20	Steel PH
P0380.028-PH	28	25.9	2.0	4.7	3.2	1.50	Steel PH
P0380.029-PH	29	26.9	2.0	4.8	3.4	1.50	Steel PH
P0380.030-PH	30	27.9	2.0	5.0	3.5	1.50	Steel PH
P0380.032-PH	32	29.6	2.5	5.2	3.6	1.50	Steel PH
P0380.034-PH	34	31.5	2.5	5.4	3.8	1.50	Steel PH
P0380.035-PH	35	32.2	2.5	5.6	3.9	1.50	Steel PH
P0380.036-PH	36	33.2	2.5	5.6	4.0	1.75	Steel PH
P0380.038-PH	38	35.2	2.5	5.8	4.2	1.75	Steel PH
P0380.039-PH	39	36.0	2.5	5.9	4.3	1.75	Steel PH
P0380.040-PH	40	36.0	2.5	6.0	4.4	1.75	Steel PH

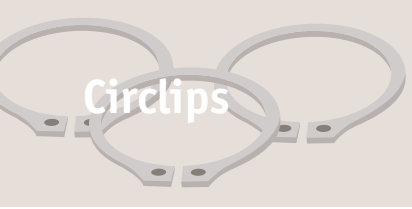

Circlips

External PH Circlips Steel phosphated



CIRCLIPS

Order No.	d ₁	d ₂	d ₃ min.	h ₁ max.	h ₂	w ₁	Material
P0380.042-PH	42	36.5	2.5	6.5	4.5	1.75	Steel PH
P0380.045-PH	45	41.5	2.5	6.7	4.7	1.75	Steel PH
P0380.048-PH	48	44.5	2.5	6.9	5.0	1.75	Steel PH
P0380.050-PH	50	45.8	2.5	6.9	5.1	2.00	Steel PH
P0380.052-PH	52	47.8	2.5	7.0	5.2	2.00	Steel PH
P0380.055-PH	55	50.8	2.5	7.2	5.4	2.00	Steel PH
P0380.060-PH	60	55.8	2.5	7.4	5.8	2.00	Steel PH
P0380.065-PH	65	60.8	3.0	7.8	6.3	2.50	Steel PH
P0380.070-PH	70	65.5	3.0	8.1	6.6	2.50	Steel PH
P0380.075-PH	75	70.5	3.0	8.4	7.0	2.50	Steel PH
P0380.080-PH	80	74.5	3.0	8.6	7.4	2.50	Steel PH
P0380.085-PH	85	79.5	3.5	8.7	7.8	3.00	Steel PH
P0380.090-PH	90	84.5	3.5	8.8	8.2	3.00	Steel PH
P0380.095-PH	95	89.5	3.5	9.4	8.6	3.00	Steel PH
P0380.100-PH	100	94.5	3.5	9.6	9.0	3.00	Steel PH
P0380.105-PH	105	98.0	3.5	9.9	9.3	4.00	Steel PH
P0380.110-PH	110	103.0	3.5	10.1	9.6	4.00	Steel PH
P0380.120-PH	120	113.0	3.5	11.0	10.2	4.00	Steel PH
P0380.130-PH	130	123.0	4.0	11.6	10.7	4.00	Steel PH
P0380.140-PH	140	133.0	4.0	12.0	11.2	4.00	Steel PH



External A2 Circlips

A2 stainless

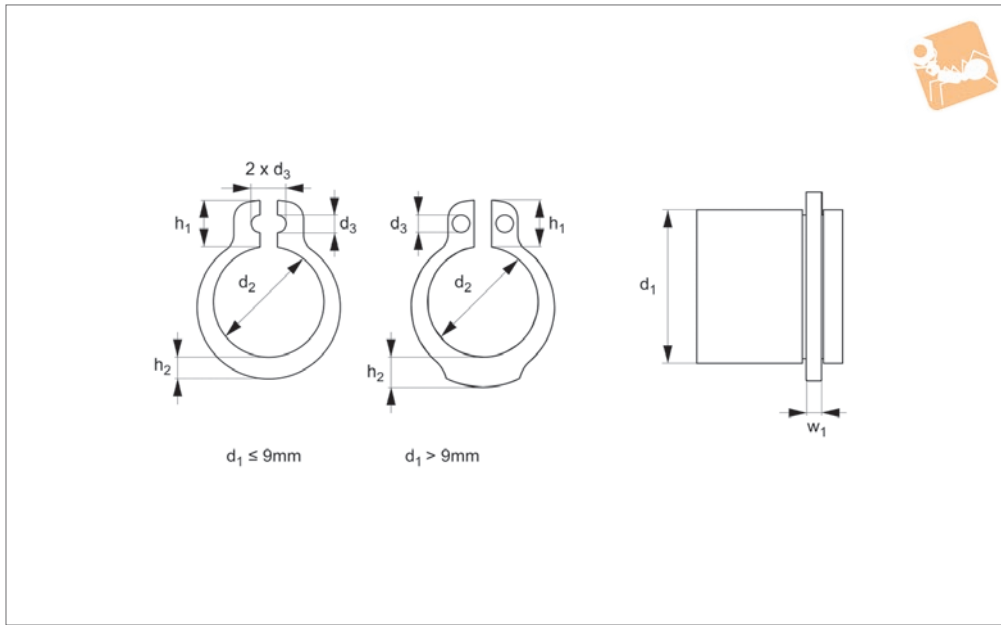
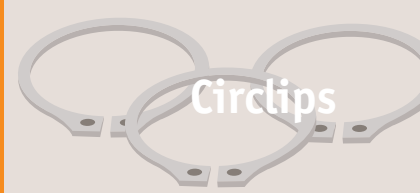

P0380.A2

CIRCLIPS

Material

Stainless steel (A2, AISI 303).

Technical Notes

To DIN 471.

Order No.	d ₁	d ₂	d ₃ min.	h ₁ max.	h ₂	w ₁	Material
P0380.003-A2	3	2.7	1.0	1.9	0.8	0.40	A2 s/s
P0380.004-A2	4	3.7	1.0	2.2	0.9	0.40	A2 s/s
P0380.005-A2	5	3.7	1.0	2.5	1.1	0.60	A2 s/s
P0380.006-A2	6	5.6	1.2	2.7	1.3	0.70	A2 s/s
P0380.007-A2	7	6.5	1.2	3.1	1.4	0.80	A2 s/s
P0380.008-A2	8	7.4	1.2	3.2	1.5	0.80	A2 s/s
P0380.009-A2	9	8.4	1.2	3.3	1.7	1.00	A2 s/s
P0380.010-A2	10	9.3	1.5	3.3	1.8	1.00	A2 s/s
P0380.011-A2	11	10.2	1.5	3.3	1.8	1.00	A2 s/s
P0380.012-A2	12	11.0	1.7	3.3	1.8	1.00	A2 s/s
P0380.013-A2	13	11.9	1.7	3.4	2.0	1.00	A2 s/s
P0380.014-A2	14	12.9	1.7	3.5	2.1	1.00	A2 s/s
P0380.015-A2	15	13.8	1.7	3.6	0.8	1.00	A2 s/s
P0380.016-A2	16	14.7	1.7	3.7	2.2	1.00	A2 s/s
P0380.017-A2	17	15.7	1.7	3.8	2.3	1.00	A2 s/s
P0380.018-A2	18	16.5	2.0	3.9	2.4	1.20	A2 s/s
P0380.019-A2	19	17.5	2.0	3.9	2.5	1.20	A2 s/s
P0380.020-A2	20	18.5	2.0	4.0	2.6	1.20	A2 s/s
P0380.022-A2	22	20.5	2.0	4.2	2.8	1.20	A2 s/s
P0380.023-A2	23	21.4	2.0	4.3	2.9	1.20	A2 s/s
P0380.024-A2	24	22.2	2.0	4.4	3.0	1.20	A2 s/s
P0380.025-A2	25	23.2	2.0	4.4	3.0	1.20	A2 s/s
P0380.026-A2	26	24.2	2.0	4.5	3.1	1.20	A2 s/s
P0380.027-A2	27	25.1	2.0	4.6	3.1	1.20	A2 s/s
P0380.028-A2	28	25.9	2.0	4.7	3.2	1.50	A2 s/s
P0380.029-A2	29	26.9	2.0	4.8	3.4	1.50	A2 s/s
P0380.030-A2	30	27.9	2.0	5.0	3.5	1.50	A2 s/s
P0380.032-A2	32	29.6	2.5	5.2	3.6	1.50	A2 s/s
P0380.034-A2	34	31.5	2.5	5.4	3.8	1.50	A2 s/s
P0380.035-A2	35	32.2	2.5	5.6	3.9	1.50	A2 s/s
P0380.036-A2	36	33.2	2.5	5.6	4.0	1.75	A2 s/s
P0380.038-A2	38	35.2	2.5	5.8	4.2	1.75	A2 s/s
P0380.039-A2	39	36.0	2.5	5.9	4.3	1.75	A2 s/s
P0380.040-A2	40	36.0	2.5	6.0	4.4	1.75	A2 s/s

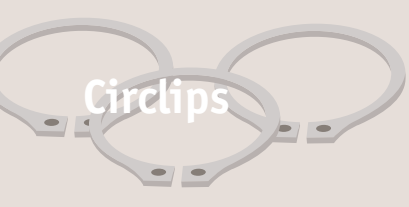

Circlips

External A2 Circlips A2 stainless



CIRCLIPS

Order No.	d ₁	d ₂	d ₃ min.	h ₁ max.	h ₂	w ₁	Material
P0380.042-A2	42	36.5	2.5	6.5	4.5	1.75	A2 s/s
P0380.045-A2	45	41.5	2.5	6.7	4.7	1.75	A2 s/s
P0380.048-A2	48	44.5	2.5	6.9	5.0	1.75	A2 s/s
P0380.050-A2	50	45.8	2.5	6.9	5.1	2.00	A2 s/s
P0380.052-A2	52	47.8	2.5	7.0	5.2	2.00	A2 s/s
P0380.055-A2	55	50.8	2.5	7.2	5.4	2.00	A2 s/s
P0380.060-A2	60	55.8	2.5	7.4	5.8	2.00	A2 s/s
P0380.065-A2	65	60.8	3.0	7.8	6.3	2.50	A2 s/s
P0380.070-A2	70	65.5	3.0	8.1	6.6	2.50	A2 s/s
P0380.075-A2	75	70.5	3.0	8.4	7.0	2.50	A2 s/s
P0380.080-A2	80	74.5	3.0	8.6	7.4	2.50	A2 s/s
P0380.085-A2	85	79.5	3.5	8.7	7.8	3.00	A2 s/s
P0380.090-A2	90	84.5	3.5	8.8	8.2	3.00	A2 s/s
P0380.095-A2	95	89.5	3.5	9.4	8.6	3.00	A2 s/s
P0380.100-A2	100	94.5	3.5	9.6	9.0	3.00	A2 s/s
P0380.105-A2	105	98.0	3.5	9.9	9.3	4.00	A2 s/s
P0380.110-A2	110	103.0	3.5	10.1	9.6	4.00	A2 s/s
P0380.120-A2	120	113.0	3.5	11.0	10.2	4.00	A2 s/s
P0380.130-A2	130	123.0	4.0	11.6	10.7	4.00	A2 s/s
P0380.140-A2	140	133.0	4.0	12.0	11.2	4.00	A2 s/s



Internal Circlips

A2 stainless

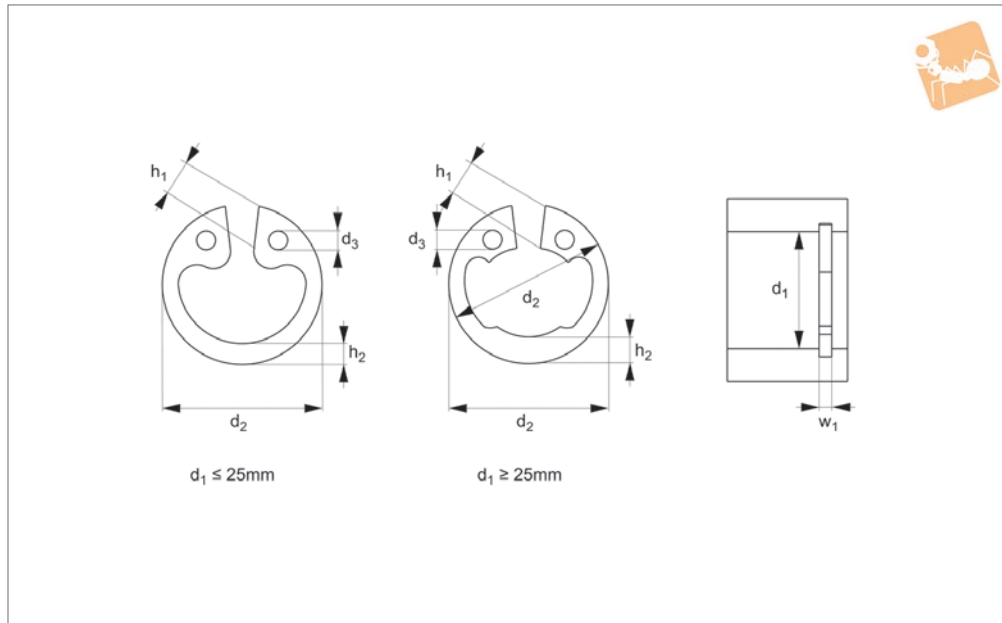
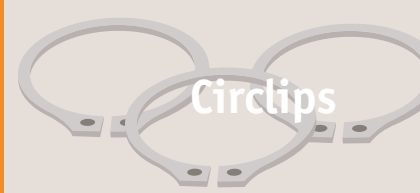

P0381.A2

CIRCLIPS

Material

Stainless steel (A2, AISI 303).

Technical Notes

To DIN 472.

Order No.	d_1	d_2	d_3 min.	h_1 max.	h_2	w_1	Material
P0381.008-A2	8	8.7	1.0	2.4	1.1	0.8	A2 s/s
P0381.009-A2	9	9.8	1.0	2.5	1.3	0.8	A2 s/s
P0381.010-A2	10	10.8	1.2	3.2	1.4	1.0	A2 s/s
P0381.011-A2	11	11.8	1.2	3.3	1.5	1.0	A2 s/s
P0381.012-A2	12	13.0	1.5	3.4	1.7	1.0	A2 s/s
P0381.013-A2	13	14.1	1.5	3.6	1.8	1.0	A2 s/s
P0381.014-A2	14	15.1	1.7	3.7	1.9	1.0	A2 s/s
P0381.015-A2	15	16.2	1.7	3.7	2.0	1.0	A2 s/s
P0381.016-A2	16	17.3	1.7	3.8	2.0	1.0	A2 s/s
P0381.017-A2	17	18.3	1.7	3.9	2.1	1.0	A2 s/s
P0381.018-A2	18	19.5	2.0	4.1	2.2	1.0	A2 s/s
P0381.019-A2	19	20.5	2.0	4.1	2.2	1.0	A2 s/s
P0381.020-A2	20	21.5	2.0	4.2	2.3	1.0	A2 s/s
P0381.021-A2	21	22.5	2.0	4.2	2.4	1.0	A2 s/s
P0381.022-A2	22	23.5	2.0	4.2	2.5	1.0	A2 s/s
P0381.023-A2	23	24.6	2.0	4.3	2.5	1.2	A2 s/s
P0381.024-A2	24	25.9	2.0	4.4	2.6	1.2	A2 s/s
P0381.025-A2	25	26.9	2.0	4.5	2.7	1.2	A2 s/s
P0381.026-A2	26	27.9	2.0	4.6	2.8	1.2	A2 s/s
P0381.027-A2	27	28.9	2.0	4.7	2.9	1.2	A2 s/s
P0381.028-A2	28	30.1	2.0	4.8	2.9	1.2	A2 s/s
P0381.029-A2	29	31.1	2.0	4.8	3.0	1.2	A2 s/s
P0381.030-A2	30	32.1	2.0	4.8	3.0	1.2	A2 s/s
P0381.031-A2	31	33.4	2.5	5.2	3.2	1.2	A2 s/s
P0381.032-A2	32	34.4	2.5	5.4	3.2	1.2	A2 s/s
P0381.034-A2	34	36.5	2.5	5.4	3.3	1.2	A2 s/s
P0381.035-A2	35	37.8	2.5	5.4	3.4	1.5	A2 s/s
P0381.036-A2	36	38.8	2.5	5.4	3.5	1.5	A2 s/s
P0381.037-A2	37	39.8	2.5	5.5	3.6	1.5	A2 s/s
P0381.038-A2	38	40.8	2.5	5.5	3.7	1.5	A2 s/s
P0381.039-A2	39	42.0	2.5	5.6	3.8	1.75	A2 s/s
P0381.040-A2	40	43.5	2.5	5.8	3.9	1.75	A2 s/s
P0381.041-A2	41	44.5	2.5	5.9	4.0	1.75	A2 s/s
P0381.042-A2	42	45.5	2.5	5.9	4.1	1.75	A2 s/s

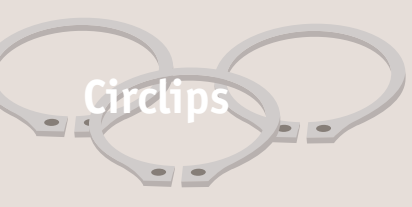

Circlips

Internal Circlips

A2 stainless

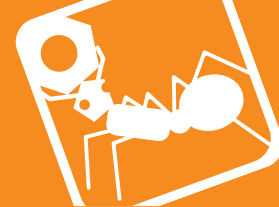

CIRCLIPS

Order No.	d ₁	d ₂	d ₃ min.	h ₁ max.	h ₂	w ₁	Material
P0381.045-A2	45	48.5	2.5	6.2	4.3	1.75	A2 s/s
P0381.047-A2	47	50.5	2.5	6.4	4.4	1.75	A2 s/s
P0381.048-A2	48	51.5	2.5	6.4	4.5	1.75	A2 s/s
P0381.050-A2	50	54.2	2.5	6.5	4.6	2.0	A2 s/s
P0381.052-A2	52	56.2	2.5	6.7	4.7	2.0	A2 s/s
P0381.055-A2	55	59.2	2.5	6.8	5.0	2.0	A2 s/s
P0381.058-A2	58	62.2	2.5	6.9	5.2	2.0	A2 s/s
P0381.060-A2	60	64.2	2.5	7.3	5.4	2.0	A2 s/s
P0381.062-A2	62	66.2	2.5	7.3	5.5	2.0	A2 s/s
P0381.065-A2	65	69.2	3.0	7.6	5.8	2.5	A2 s/s
P0381.068-A2	68	72.5	3.0	7.8	6.1	2.5	A2 s/s
P0381.070-A2	70	74.5	3.0	7.8	6.2	2.5	A2 s/s
P0381.072-A2	72	76.5	3.0	7.8	6.4	2.5	A2 s/s
P0381.075-A2	75	79.5	3.0	7.8	6.6	2.5	A2 s/s
P0381.080-A2	80	85.5	3.0	8.5	7.0	2.5	A2 s/s
P0381.085-A2	85	90.5	3.5	8.6	7.2	3.0	A2 s/s
P0381.090-A2	90	95.5	3.5	8.6	7.6	3.0	A2 s/s
P0381.095-A2	95	100.5	3.5	8.6	8.1	3.0	A2 s/s
P0381.100-A2	100	105.5	3.5	9.2	8.4	3.0	A2 s/s
P0381.105-A2	105	112.0	3.5	9.5	8.7	4.0	A2 s/s
P0381.110-A2	110	117.0	3.5	10.4	9.0	4.0	A2 s/s
P0381.120-A2	120	127.0	3.5	11.0	9.7	4.0	A2 s/s
P0381.130-A2	130	137.0	4.0	11.0	10.2	4.0	A2 s/s
P0381.140-A2	140	147.0	4.0	11.2	10.7	4.0	A2 s/s



E Clips

A2 stainless

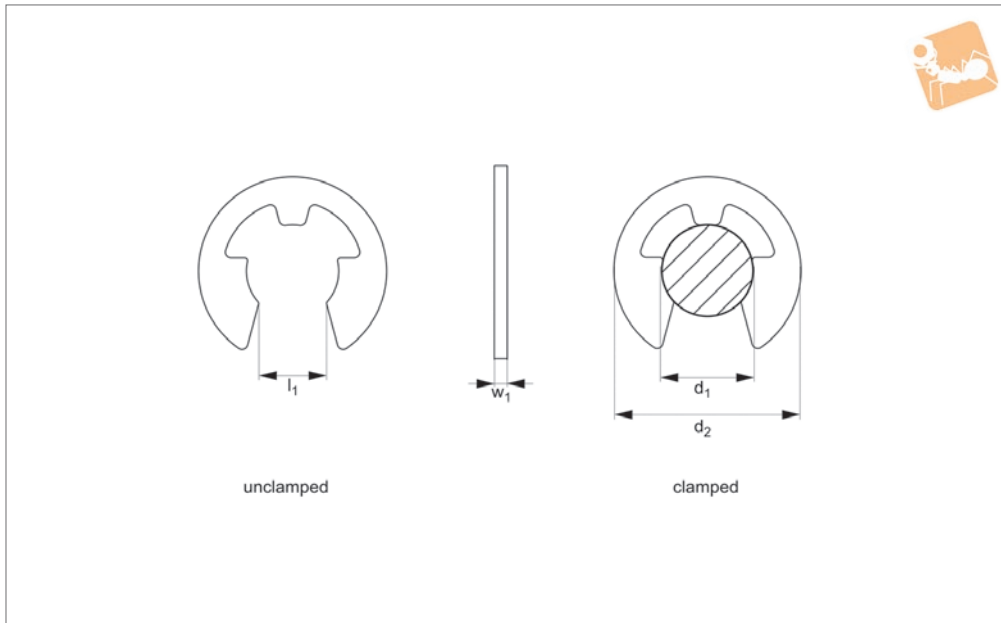
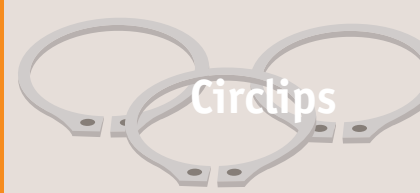

P0382.A2

CIRCLIPS

Material

Stainless steel (A2, AISI 303).

Technical Notes

To DIN 6799.

Order No.	d ₁	For shaft dia.	d ₂	l ₁	w ₁	Material
P0382.012-A2	1.2	1,4-2,0	3.25	1.01	0.30	A2 s/s
P0382.015-A2	1.5	2,0-2,5	4.25	1.28	0.40	A2 s/s
P0382.019-A2	1.9	2,5-3,0	4.80	1.61	0.50	A2 s/s
P0382.023-A2	2.3	3,0-4,0	6.30	1.94	0.60	A2 s/s
P0382.032-A2	3.2	4,0-5,0	7.30	2.70	0.60	A2 s/s
P0382.040-A2	4.0	5,0-7,0	9.30	3.34	0.70	A2 s/s
P0382.050-A2	5.0	6,0-8,0	11.30	4.11	0.70	A2 s/s
P0382.060-A2	6.0	7,0-9,0	12.30	5.26	0.70	A2 s/s
P0382.070-A2	7.0	8,0-11,0	14.30	5.84	0.90	A2 s/s
P0382.080-A2	8.0	9,0-12,0	16.30	6.52	1.00	A2 s/s
P0382.090-A2	9.0	10,0-14,0	18.80	7.63	1.10	A2 s/s
P0382.100-A2	10.0	11,0-15,0	20.40	8.32	1.20	A2 s/s
P0382.120-A2	12.0	13,0-18,0	23.40	10.45	1.30	A2 s/s
P0382.150-A2	15.0	16,0-24,0	29.40	12.61	1.50	A2 s/s
P0382.190-A2	19.0	20,0-31,0	37.60	15.92	1.75	A2 s/s
P0382.240-A2	24.0	25,0-38,0	44.60	21.88	2.00	A2 s/s

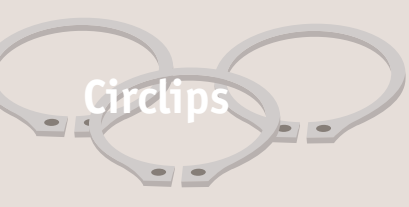

Circlips

E Clips Steel phosphated



CIRCLIPS



P0382.PH

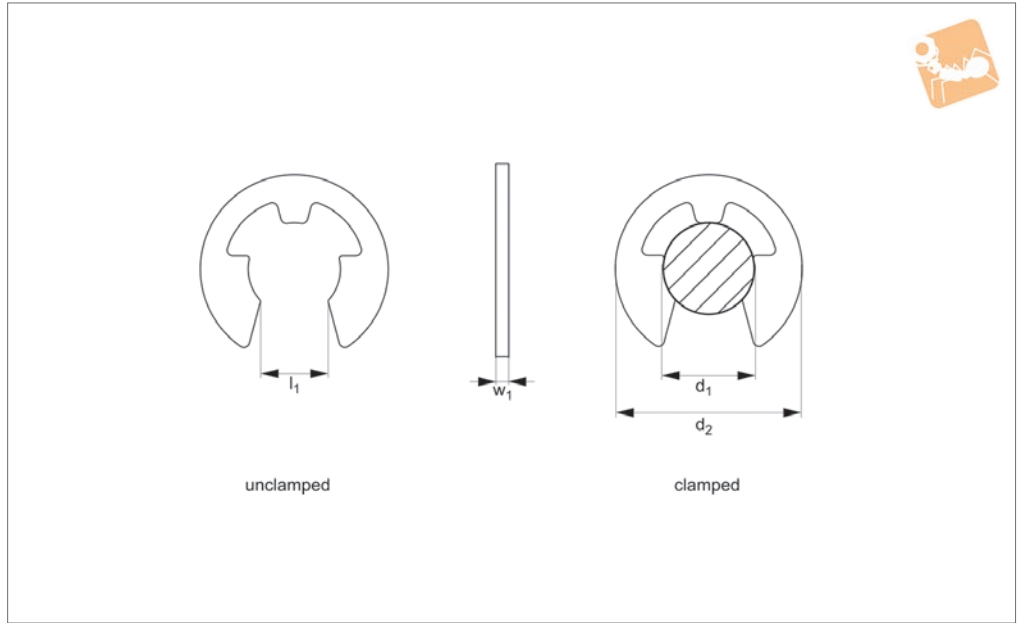

Material
Steel, phosphated.

Technical Notes
To DIN 6799.

Order No.	d ₁	For shaft dia.	d ₂	l ₁	w ₁	Material
P0382.012-PH	1.2	1,4-2,0	3.25	1.01	0.30	Steel PH
P0382.015-PH	1.5	2,0-2,5	4.25	1.28	0.40	Steel PH
P0382.019-PH	1.9	2,5-3,0	4.80	1.61	0.50	Steel PH
P0382.023-PH	2.3	3,0-4,0	6.30	1.94	0.60	Steel PH
P0382.032-PH	3.2	4,0-5,0	7.30	2.70	0.60	Steel PH
P0382.040-PH	4.0	5,0-7,0	9.30	3.34	0.70	Steel PH
P0382.050-PH	5.0	6,0-8,0	11.30	4.11	0.70	Steel PH
P0382.060-PH	6.0	7,0-9,0	12.30	5.26	0.70	Steel PH
P0382.070-PH	7.0	8,0-11,0	14.30	5.84	0.90	Steel PH
P0382.080-PH	8.0	9,0-12,0	16.30	6.52	1.00	Steel PH
P0382.090-PH	9.0	10,0-14,0	18.80	7.63	1.10	Steel PH
P0382.100-PH	10.0	11,0-15,0	20.40	8.32	1.20	Steel PH
P0382.120-PH	12.0	13,0-18,0	23.40	10.45	1.30	Steel PH
P0382.150-PH	15.0	16,0-24,0	29.40	12.61	1.50	Steel PH
P0382.190-PH	19.0	20,0-31,0	37.60	15.92	1.75	Steel PH
P0382.240-PH	24.0	25,0-38,0	44.60	21.88	2.00	Steel PH