

All of our rod ends incorporate either a plain spherical bearing, ball bearing, or roller bearing. Below is an overview of each type.

Plain spherical bearings

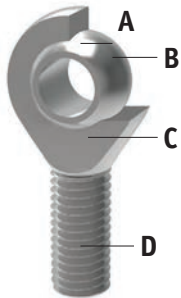

- A** Made from Polyamid-PTFE-fibreglass-compound, maintenance free, absorbs any foreign particles
- B** Ball made of bearing steel, hardened, ground, polished and hard chromium plated, ensures reliable corrosion protection
- C** No clearance - radial clearance 0-10µm
- D** All rod ends housings made of forged steel, tempered, extremely high loads resistant

Ball and roller bearings

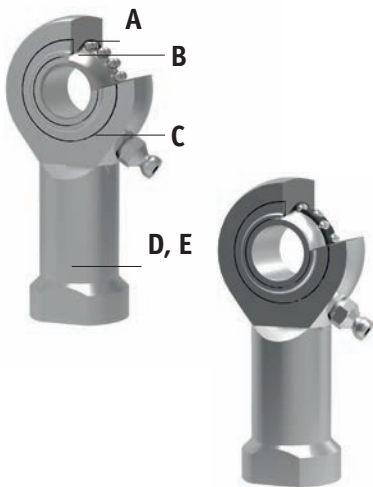

- A** Radial clearance: 10-30µm, low friction
- B** Inner ring made of bearing steel, hardened ball grooves polished
- C** Shields on both sides protect against rough dirt penetration
- D** All rod ends housings are made of forged steel, case hardened bearing race
- E** Low maintenance due to long-term greasing, especially suitable for high speed large swiveling angles or rotating movements

Rod ends and water



Stainless steel versions

Most of our rod ends are available in stainless steel as standard

High grade AISI 316 stainless steel available on request

Rod Ends from Automation Components

ROD ENDS



R3550

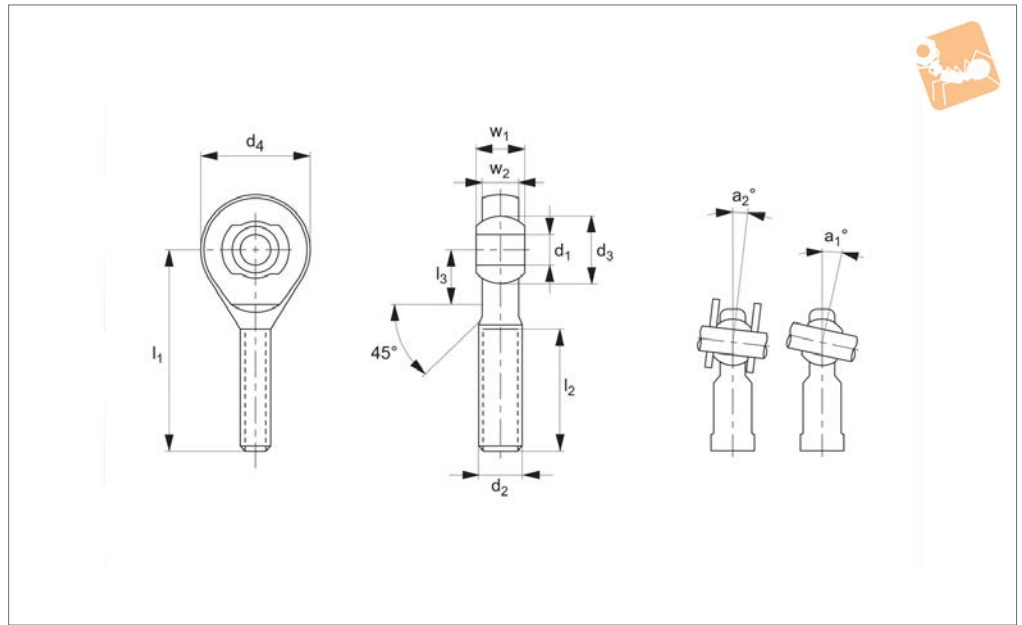

Material

Housing - forged steel, tempered, rolled thread, surface galvanized.

Joint ball - ball bearing steel, hardened and ground.

Race - nylon/teflon/glass compound.

Technical Notes

Maintenance free, sizes according to DIN ISO 12240-4, series K, for tolerances see technical pages.

Tips

Standard thread is right hand thread.

Important Notes

*Denotes fine pitch thread.

Order No.	Thread hand	d ₁	l ₁	d ₂	d ₃	l ₂	d ₄	a ₁	Weight g
R3550.R005	Right	5	33	M5	11.11	20	18	13.0	14
R3550.R006	Right	6	36	M6	12.70	22	20	13.0	20
R3550.R008	Right	8	42	M8	15.87	25	24	14.5	38
R3550.R010	Right	10	48	M10	19.05	29	28	13.5	60
R3550.R012	Right	12	54	M12	22.22	33	32	13.0	92
R3550.R014	Right	14	60	M14	25.40	36	36	16.0	127
R3550.R016	Right	16	66	M16	28.57	40	42	15.5	202
R3550.R018	Right	18	72	M18x1,5*	31.75	44	46	15.0	250
R3550.R020	Right	20	78	M20x1,5*	34.92	47	50	14.5	327
R3550.R022	Right	22	84	M22x1,5*	38.10	51	54	15.5	440
R3550.R025	Right	25	94	M24x2*	42.85	57	60	15.0	630
R3550.R030	Right	30	110	M30x2*	50.75	66	70	17.0	1015
R3550.L005	Left	5	33	M5	11.11	20	18	13.0	14
R3550.L006	Left	6	36	M6	12.70	22	20	13.0	20
R3550.L008	Left	8	42	M8	15.87	25	24	14.5	38
R3550.L010	Left	10	48	M10	19.05	29	28	13.5	60
R3550.L012	Left	12	54	M12	22.22	33	32	13.0	92
R3550.L014	Left	14	60	M14	25.40	36	36	16.0	127
R3550.L016	Left	16	66	M16	28.57	40	42	15.5	202
R3550.L018	Left	18	72	M18x1,5*	31.75	44	46	15.0	250
R3550.L020	Left	20	78	M20x1,5*	34.92	47	50	14.5	327
R3550.L022	Left	22	84	M22x1,5*	38.10	51	54	15.5	440
R3550.L025	Left	25	94	M24x2*	42.85	57	60	15.0	630
R3550.L030	Left	30	110	M30x2*	50.80	66	70	17.0	1015

Order No.	a ₂	l ₃	w ₁	w ₂	Dyn. load C kN max.	Static load C ₀ kN max.
R3550.R005	7.5	9	8	6.00	3.9	5.6
R3550.R006	6.5	12	9	6.75	4.6	7.8
R3550.R008	7.5	15	12	9.00	7.0	14.3
R3550.R010	8.0	15	14	10.50	10.4	22.6



Heavy-Duty Rod Ends - Male

with integral spherical plain bearing

Rod Ends

Order No.	a_2	l_3	w_1	w_2	Dyn. load C kN max.	Static load C_0 kN max.
R3550.R012	8.0	19	16	12.00	12.4	32.8
R3550.R014	9.5	20	19	13.50	15.4	41.3
R3550.R016	8.5	22	21	15.00	22.4	56.6
R3550.R018	9.5	25	23	16.50	26.3	69.7
R3550.R020	9.0	28	25	18.00	30.8	82.2
R3550.R022	10.0	26	28	20.00	38.2	95.6
R3550.R025	10.0	30	31	22.00	45.3	118.6
R3550.R030	10.5	35	37	25.00	55.0	145.6
R3550.L005	7.5	9	8	6.00	3.9	5.6
R3550.L006	6.5	12	9	6.75	4.6	7.8
R3550.L008	7.5	15	12	9.00	7.0	14.3
R3550.L010	8.0	15	14	10.50	10.4	22.6
R3550.L012	8.0	19	16	12.00	12.4	32.8
R3550.L014	9.5	20	19	13.50	15.4	41.3
R3550.L016	8.5	22	21	15.00	22.4	56.6
R3550.L018	9.5	25	23	16.50	26.325	69.700
R3550.L020	9.0	28	25	18.00	30.805	82.200
R3550.L022	10.0	26	28	20.00	38.2	95.6
R3550.L025	10.0	30	31	22.00	45.3	118.6
R3550.L030	10.5	35	37	25.00	55.0	145.6

ROD ENDS



R3550.i

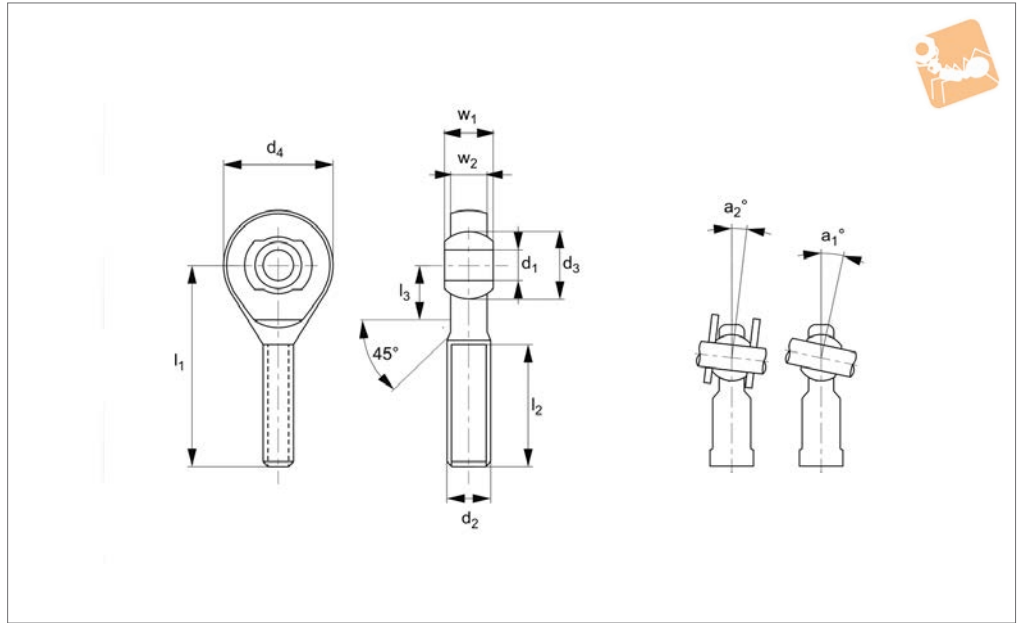

Material

Rod end housing - forged steel, tempered, rolled thread, surface galvanized.
 Joint ball - ball bearing steel, hardened and ground.
 Race - nylon/teflon/glass compound.

Technical Notes

Male thread maintenance free adapter sizes according to DIN ISO 12240-4, series K.

Tips

Standard thread is Right hand thread.

Important Notes

*Denotes fine pitch thread.

Order No.	Thread hand	d ₁	l ₁	d ₂	d ₃	l ₂	d ₄	a _o	l ₃	w ₁	w ₂	Dyn. load C kN max.	Static load C ₀ kN max.	Weight g
R3550.i250	Right	0.250	1.594	1/4-28	0.516	1.000	0.750	13.0	0.511	0.374	0.283	3.6	13.5	22
R3550.i375	Right	0.375	1.948	3/8-24	0.719	1.240	1.000	9.5	0.629	0.499	0.405	7.7	21.0	49
R3550.i500	Right	0.500	2.460	1/2-20	0.876	1.500	1.311	13.0	0.846	0.624	0.472	14.7	40.3	109
R3550.i625	Right	0.625	2.618	5/8-18	1.125	1.574	1.654	15.5	0.944	0.827	0.590	22.4	56.0	202
R3550.i750	Right	0.750	2.893	3/4-16	1.249	1.750	1.750	11.0	1.023	0.874	0.688	24.9	62.2	249
R3550.i1000	Right	1.000	3.720	1-12	1.688	2.244	2.362	15.5	1.200	1.220	0.866	45.4	113.4	562
R3550.i1001	Right	1.000	3.720	1-14	1.688	2.244	2.362	15.5	1.200	1.220	0.866	45.4	113.4	562
R3550.iL250	Left	0.250	1.594	1/4-28	0.516	1.000	0.750	13.0	0.511	0.374	0.283	3.6	13.5	22
R3550.iL375	Left	0.375	1.948	3/8-24	0.719	1.240	1.000	9.5	0.629	0.499	0.405	7.7	21.0	49
R3550.iL500	Left	0.500	2.460	1/2-20	0.876	1.500	1.311	13.0	0.846	0.624	0.472	14.7	40.3	109
R3550.iL625	Left	0.625	2.618	5/8-18	1.125	1.574	1.654	15.5	0.944	0.827	0.590	22.4	56.0	202
R3550.iL750	Left	0.750	2.893	3/4-16	1.249	1.750	1.750	11.0	1.023	0.874	0.688	24.9	62.2	249
R3550.iL1000	Left	1.000	3.720	1-12	1.688	2.244	2.362	15.5	1.200	1.220	0.866	45.4	113.4	562
R3550.iL1001	Left	1.000	3.720	1-14	1.688	2.244	2.362	15.5	1.200	1.220	0.866	45.4	113.4	562



Heavy-Duty Rod Ends - Male with integral spherical plain bearing

Rod Ends

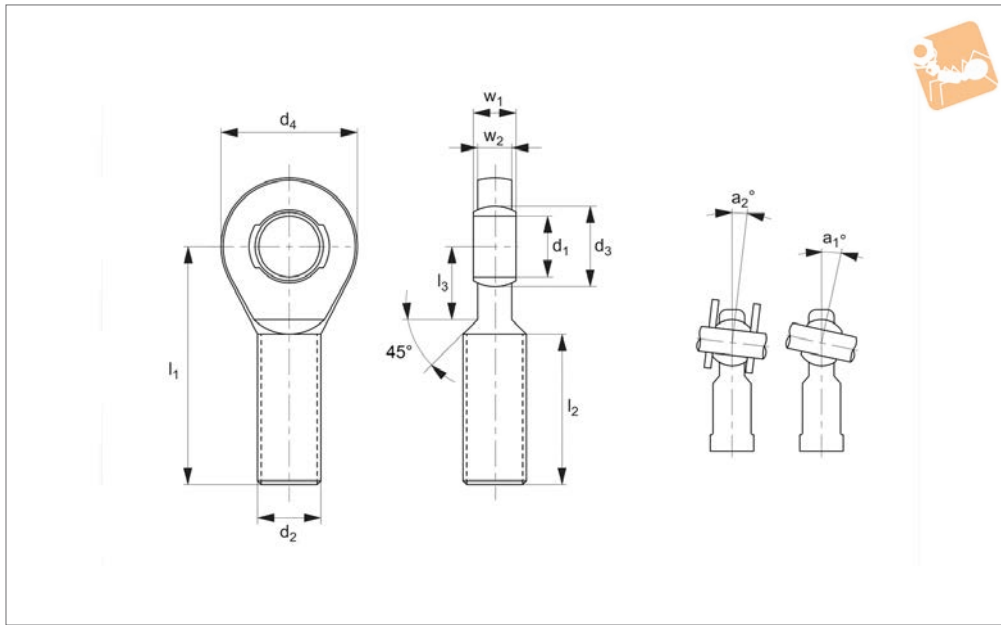

R3553

ROD ENDS

Material

Housing - forged steel, tempered, rolled thread, surface galvanized.

Joint ball - ball bearing steel, hardened and ground, surface superfinished and chromium plated.

Race - nylon/teflon/glass compound.

Technical Notes

Maintenance free, sizes according to DIN ISO 12240-4, series E, for tolerances tech-

nical pages.

Tips

Standard thread is right hand thread.

Important Notes

*Denotes fine pitch thread.

Order No.	Thread hand	d ₁	l ₁	d ₂	d ₃	l ₂	d ₄	a ₁	Weight g
R3553.R006	Right	6	36	M6	10.0	22	20	13.0	14
R3553.R008	Right	8	42	M8	13.0	25	23	15.0	24
R3553.R010	Right	10	48	M10	16.0	29	28	12.0	41
R3553.R012	Right	12	54	M12	18.0	33	32	10.5	67
R3553.R015	Right	15	63	M14	22.0	33	38	8.5	110
R3553.R017	Right	17	69	M16	25.0	40	44	10.0	163
R3553.R020	Right	20	78	M20x1,5*	29.0	47	51	9.0	270
R3553.R025	Right	25	94	M24x2*	35.5	57	62	7.5	508
R3553.R030	Right	30	110	M30x2*	40.7	66	70	6.0	785
R3553.R035	Right	35	140	M36x3*	47.0	92	82	6.5	1330
R3553.R040	Right	40	145	M42x3*	53.0	94	92	7.0	1890
R3553.R041	Right	40	150	M39x3*	53.0	99	92	7.0	1785
R3553.R045	Right	45	165	M45x3*	60.0	100	102	7.5	2620
R3553.R046	Right	45	163	M42x3*	60.0	98	102	7.5	2430
R3553.R050	Right	50	195	M52x3*	66.0	120	112	6.5	3865
R3553.R051	Right	50	185	M45x3*	66.0	110	112	6.5	3225
R3553.R060	Right	60	225	M60x4*	80.0	140	135	6.5	6400
R3553.R061	Right	60	210	M60x4*	80.0	125	-	6.5	5430
R3553.L006	Left	6	36	M6	10.0	22	20	13.0	14
R3553.L008	Left	8	42	M8	13.0	25	23	15.0	24
R3553.L010	Left	10	48	M10	16.0	29	28	12.0	41
R3553.L012	Left	12	54	M12	18.0	33	32	10.5	67
R3553.L015	Left	15	63	M14	22.0	33	38	8.5	110
R3553.L017	Left	17	69	M16	25.0	40	44	10.0	163
R3553.L020	Left	20	78	M20x1,5*	29.0	47	51	9.0	270
R3553.L025	Left	25	94	M24x2*	35.5	57	62	7.5	508
R3553.L030	Left	30	110	M30x2*	40.7	66	70	6.0	785
R3553.L035	Left	35	140	M36x3*	47.0	92	82	6.5	1330
R3553.L040	Left	40	145	M42x3*	53.0	94	92	7.0	1890
R3553.L041	Left	40	150	M39x3*	53.0	99	92	7.0	1785
R3553.L045	Left	45	165	M45x3*	60.0	100	102	7.5	2620
R3553.L046	Left	45	163	M42x3*	60.0	98	102	7.5	2430



Order No.	Thread hand	d ₁	l ₁	d ₂	d ₃	l ₂	d ₄	a ₁	Weight g
R3553.L050	Left	50	195	M52x3,0*	66.0	120	112	6.5	3865
R3553.L051	Left	50	185	M45x3,0*	66.0	110	112	6.5	3225
R3553.L060	Left	60	225	M60x4,0*	80.0	140	135	6.5	6400
R3553.L061	Left	60	210	M52x3,0*	80.0	125	135	6.5	5430

Order No.	a ₂	l ₃	w ₁	w ₂	Dyn. load C kN max.	Static load C ₀ kN max.
R3553.R006	6.5	11	6	4	2.5	6.4
R3553.R008	8.0	12	8	5	4.2	11.0
R3553.R010	6.0	15	9	6	6.4	16.8
R3553.R012	5.0	15	10	7	9.2	23.0
R3553.R015	4.5	18	12	9	13.4	39.6
R3553.R017	5.5	23	14	10	19.2	54.1
R3553.R020	4.5	25	16	12	25.2	76.7
R3553.R025	3.5	32	20	16	42.4	119.1
R3553.R030	3.0	35	22	18	54.0	141.8
R3553.R035	3.5	38	25	20	70.4	180.8
R3553.R040	3.5	42	28	22	86.0	222.6
R3553.R041	3.5	42	28	22	86.0	222.6
R3553.R045	4.0	50	32	25	107.0	276.2
R3553.R046	4.0	50	32	25	107.0	276.2
R3553.R050	3.0	60	35	28	132.0	339.2
R3553.R051	3.0	60	35	28	132.0	339.2
R3553.R060	3.5	70	44	36	208.0	532.1
R3553.R061	3.5	70	44	36	208.0	532.1
R3553.L006	6.5	11	6	4	2.5	6.4
R3553.L008	8.0	12	8	5	4.2	11.0
R3553.L010	6.0	15	9	6	6.4	16.8
R3553.L012	5.0	15	10	7	9.2	23.0
R3553.L015	4.5	18	12	9	13.4	39.6
R3553.L017	5.5	23	14	10	19.2	54.1
R3553.L020	4.5	25	16	12	25.2	76.7
R3553.L025	3.5	32	20	16	42.4	119.1
R3553.L030	3.0	35	22	18	54.0	141.8
R3553.L035	3.5	38	25	20	70.4	180.8
R3553.L040	3.5	42	28	22	86.0	222.6
R3553.L041	3.5	42	28	22	86.0	222.6
R3553.L045	4.0	50	32	25	107.0	276.2
R3553.L046	4.0	50	32	25	107.0	276.2
R3553.L050	3.0	60	35	28	132.0	339.2
R3553.L051	3.0	60	35	28	132.0	339.2
R3553.L060	3.5	70	44	36	208.0	532.1
R3553.L061	3.5	70	44	36	208.0	532.1



Heavy-Duty Rod Ends - Male with integral ball bearing

Rod Ends

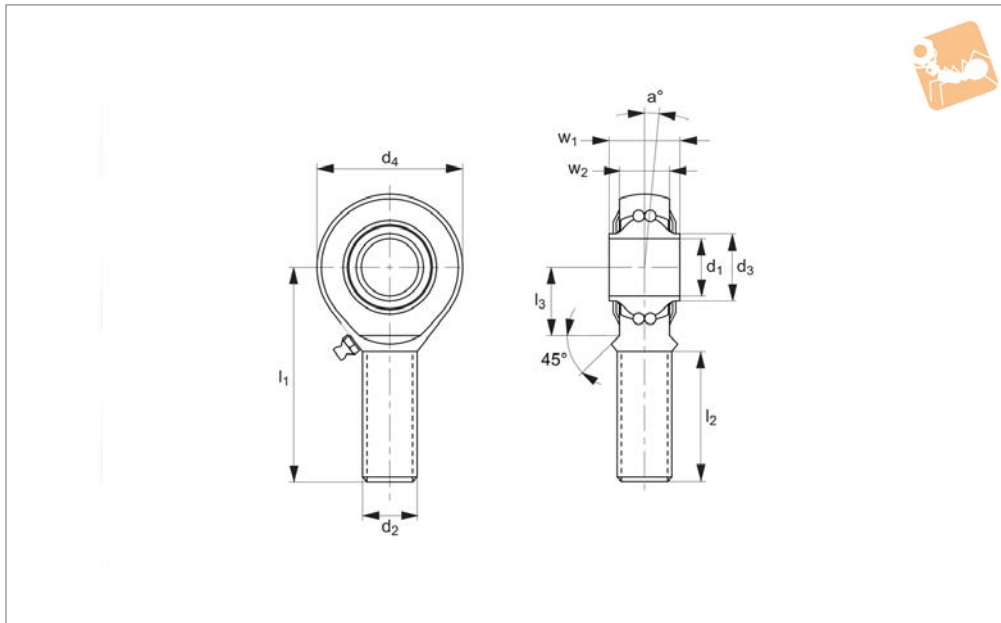

R3556

ROD ENDS

Material

Housing - forged steel, tempered, case hardened bearing race, ground and lapped, rolled thread, surface galvanized.
Inner ring - ball bearing steel, hardened, superfine ground, lubrication - calcium-complex-soap-grease, temp range -20°C to +120°C.

Lubrication nipple - DIN 3405 D1/A (sizes 6 to 10) DIN 71412 H1 (sizes 12 to 30).

technical pages.

Tips

Standard thread is right hand thread.

Technical Notes

Low maintenance. Sizes according to DIN ISO 12240-4 series K, for tolerances see

Important Notes

*Denotes fine pitch thread.

Order No.	Thread hand	d ₁	l ₁	d ₂	d ₃	l ₂	d ₄	a°	l ₃	w ₁	Weight g
R3556.R006	Right	6	36	M6	9.0	22	20	8.0	12	9	19
R3556.R008	Right	8	42	M8	10.5	25	24	8.5	15	12	36
R3556.R010	Right	10	48	M10	12.0	29	28	8.0	15	14	60
R3556.R012	Right	12	54	M12	14.5	33	32	7.5	19	16	87
R3556.R014	Right	14	60	M14	17.0	36	36	6.0	20	19	135
R3556.R016	Right	16	66	M16	19.0	40	42	8.0	22	21	190
R3556.R018	Right	18	72	M18x1,5*	21.5	44	46	8.5	25	23	270
R3556.R020	Right	20	78	M20x1,5*	24.5	47	50	7.0	28	25	338
R3556.R022	Right	22	84	M22x1,5*	26.0	51	54	8.0	26	28	450
R3556.R025	Right	25	94	M24x2*	29.5	57	64	5.0	30	31	602
R3556.R030	Right	30	110	M30x2*	34.5	66	70	7.5	35	37	922
R3556.L006	Left	6	36	M6	9.0	22	20	8.0	12	9	19
R3556.L008	Left	8	42	M8	10.5	25	24	8.5	15	12	36
R3556.L010	Left	10	48	M10	12.0	29	28	8.0	15	14	60
R3556.L012	Left	12	54	M12	14.5	33	32	7.5	19	16	87
R3556.L014	Left	14	60	M14	17.0	36	36	6.0	20	19	135
R3556.L016	Left	16	66	M16	19.0	40	42	8.0	22	21	190
R3556.L018	Left	18	72	M18x1,5*	21.5	44	46	8.5	25	23	270
R3556.L020	Left	20	78	M20x1,5*	24.5	47	50	7.0	28	25	338
R3556.L022	Left	22	84	M22x1,5*	26.0	51	54	8.0	26	28	450
R3556.L025	Left	25	94	M24x2*	29.5	57	64	5.0	30	31	602
R3556.L030	Left	30	110	M30x2*	34.5	66	70	7.5	35	37	922

Order No.	w ₂	Calc. factor Y	Calc. factor Y ₀	Dyn. load C kN max.	Speed rpm max.	Static load C ₀ kN max.
R3556.R006	6.75	2.19	2.09	2.75	1350	0.65
R3556.R008	9.00	1.89	1.80	4.00	1300	1.00
R3556.R010	10.50	1.81	1.90	4.45	1225	1.45



Order No.	w ₂	Calc. factor Y	Calc. factor Y ₀	Dyn. load C kN max.	Speed rpm max.	Static load C ₀ kN max.
R3556.R012	12.00	1.82	1.74	4.95	1125	1.80
R3556.R014	13.50	2.48	2.36	5.60	1025	2.00
R3556.R016	15.00	2.35	2.24	6.25	975	2.35
R3556.R018	16.50	2.31	2.21	7.10	900	2.90
R3556.R020	18.00	2.58	2.46	7.90	825	3.45
R3556.R022	20.00	2.24	2.35	9.30	725	3.98
R3556.R025	22.00	2.12	2.02	11.03	600	5.68
R3556.R030	25.00	2.35	2.24	14.15	450	7.45
R3556.L006	6.75	2.19	2.09	2.75	1350	0.65
R3556.L008	9.00	1.89	1.80	4.00	1300	1.00
R3556.L010	10.50	1.81	1.90	4.45	1225	1.45
R3556.L012	12.00	1.82	1.74	4.95	1125	1.80
R3556.L014	13.50	2.48	2.36	5.60	1025	2.00
R3556.L016	15.00	2.35	2.24	6.25	975	2.35
R3556.L018	16.50	2.31	2.21	7.10	900	2.90
R3556.L020	18.00	2.58	2.46	7.90	825	3.45
R3556.L022	20.00	2.24	2.35	9.30	725	3.98
R3556.L025	22.00	2.12	2.02	11.03	600	5.68
R3556.L030	25.00	2.35	2.24	14.15	450	7.45



Heavy-Duty Rod Ends - Male with integral ball bearing

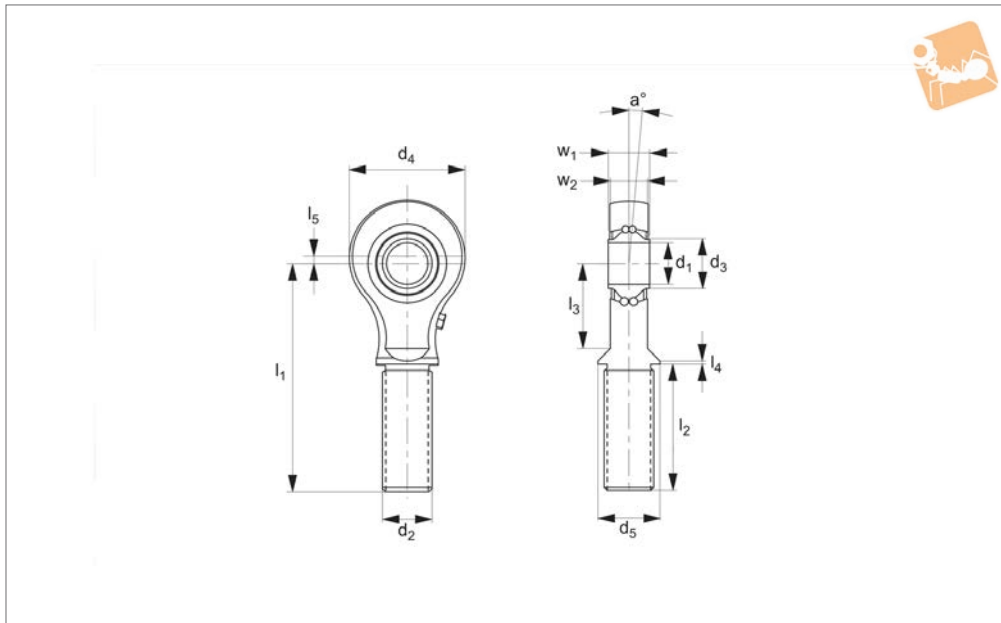

R3559

ROD ENDS

Material

Housing - forged steel, tempered, case hardened bearing race, ground and lapped, surface galvanized.
Inner ring - ball bearing steel, hardened, superfine ground.
Lubrication - calcium-complex-soap-

grease, temp range -20°C to +120°C, lubrication nipple - DIN 3405 D1/A.

Tips

Standard thread is right hand thread.

Technical Notes

Low maintenance, for tolerances see technical pages.

Important Notes

*Denotes fine pitch thread.

Order No.	Thread hand	d ₁	l ₁	d ₂	d ₃	l ₂	d ₄	d ₅	a	l ₃	Weight g
R3559.R006	Right	6	64.0	M10x1	8.5	42.5	24	14	10.5	17	62
R3559.R007	Right	6	40.5	M10x1	8.5	19	24	14	10.5	17	57
R3559.R008	Right	8	72.0	M12x1,5	11.0	46.5	30	17	8.5	20	97
R3559.R009	Right	8	48.5	M12x1,5	11.0	23	30	17	8.5	20	88
R3559.R010	Right	10	82.0	M14x1,5	13.5	49.5	36	19	9.5	28	168
R3559.R011	Right	10	58.5	M14x1,5	13.5	26	36	19	9.5	28	154
R3559.R012	Right	12	90.0	M16x1,5	15.0	53.5	40	21	7.5	31	226
R3559.R013	Right	12	65.5	M16x1,5	15.0	29	40	21	7.5	31	204
R3559.R015	Right	15	100.0	M20x1,5	18.5	62.5	42	26	6.5	30	310
R3559.R016	Right	15	73.5	M20x1,5	18.5	36	42	26	6.5	30	273
R3559.R017	Right	17	105.0	M20x1,5	21.0	62.5	48	26	7.0	36	401
R3559.R018	Right	17	78.5	M20x1,5	21.0	36	48	26	7.0	36	354
R3559.R020	Right	20	117.0	M24x1,5	24.0	68.5	56	30	5.5	41	587
R3559.R021	Right	20	89.5	M24x1,5	24.0	41	56	30	5.5	41	519
R3559.L006	Left	6	64.0	M10x1	8.5	42.5	24	14	10.5	17	62
R3559.L007	Left	6	40.5	M10x1	8.5	19	24	14	10.5	17	57
R3559.L008	Left	8	72.0	M12x1,5	11.0	46.5	30	17	8.5	20	97
R3559.L009	Left	8	48.5	M12x1,5	11.0	23	30	17	8.5	20	88
R3559.L010	Left	10	82.0	M14x1,5	13.5	49.5	36	19	9.5	28	168
R3559.L011	Left	10	58.5	M14x1,5	13.5	26	36	19	9.5	28	154
R3559.L012	Left	12	90.0	M16x1,5	15.0	53.5	40	21	7.5	31	226
R3559.L013	Left	12	65.5	M16x1,5	15.0	29	40	21	7.5	31	204
R3559.L015	Left	15	100.0	M20x1,5	18.5	62.5	42	26	6.5	30	310
R3559.L016	Left	15	73.5	M20x1,5	18.5	36	42	26	6.5	30	273
R3559.L017	Left	17	105.0	M20x1,5	21.0	62.5	48	26	7.0	36	401
R3559.L018	Left	17	78.5	M20x1,5	21.0	36	48	26	7.0	36	354
R3559.L020	Left	20	117.0	M24x1,5	24.0	68.5	56	30	5.5	41	587
R3559.L021	Left	20	89.5	M24x1,5	24.0	41	56	30	5.5	41	519



Order No.	l_4	l_5	w_1	w_2	Calc. factor Y	Calc. factor Y_0	Dyn. load C kN max.	Speed rpm max.	Static load C_0 kN max.
R3559.R006	2.5	1.5	14	10	1.28	1.34	2.44	1300	0.76
R3559.R007	2.5	1.5	14	10	1.28	1.34	2.44	1300	0.76
R3559.R008	2.5	2.0	15	10	1.9	1.81	2.60	1225	0.98
R3559.R009	2.5	2.0	15	10	1.9	1.81	2.60	1225	0.98
R3559.R010	2.5	2.5	20	14	1.69	1.77	5.12	1100	1.90
R3559.R011	2.5	2.5	20	14	1.69	1.77	5.12	1100	1.90
R3559.R012	2.5	3.0	20	14	1.81	1.90	5.34	1050	2.06
R3559.R013	2.5	3.0	20	14	1.81	1.90	5.34	1050	2.06
R3559.R015	2.5	3.0	20	14	2.07	2.17	5.48	975	3.27
R3559.R016	2.5	3.0	20	14	2.07	2.17	5.48	975	3.27
R3559.R017	2.5	3.5	22	16	2.35	2.46	5.57	875	2.68
R3559.R018	2.5	3.5	22	16	2.35	2.46	5.57	875	2.68
R3559.R020	3.0	3.5	24	18	2.76	2.90	6.16	775	3.14
R3559.R021	3.0	3.5	24	18	2.76	2.90	6.16	775	3.14
R3559.L006	2.5	1.5	14	10	1.28	1.34	2.44	1300	0.76
R3559.L007	2.5	1.5	14	10	1.28	1.34	2.44	1300	0.76
R3559.L008	2.5	2.0	15	10	1.9	1.81	2.60	1225	0.98
R3559.L009	2.5	2.0	15	10	1.9	1.81	2.60	1225	0.98
R3559.L010	2.5	2.5	20	14	1.69	1.77	5.12	1100	1.90
R3559.L011	2.5	2.5	20	14	1.69	1.77	5.12	1100	1.90
R3559.L012	2.5	3.0	20	14	1.81	1.90	5.34	1050	2.06
R3559.L013	2.5	3.0	20	14	1.81	1.90	5.34	1050	2.06
R3559.L015	2.5	3.0	20	14	2.07	2.17	5.48	975	3.27
R3559.L016	2.5	3.0	20	14	2.07	2.17	5.48	975	2.68
R3559.L017	2.5	3.5	22	16	2.35	2.46	5.57	875	2.68
R3559.L018	2.5	3.5	22	16	2.35	2.46	5.57	875	2.68
R3559.L020	3.0	3.5	24	18	2.76	2.90	6.16	775	3.14
R3559.L021	3.0	3.5	24	18	2.76	2.90	6.16	775	3.14



Heavy-Duty Rod Ends - Male with integral roller bearing

Rod Ends

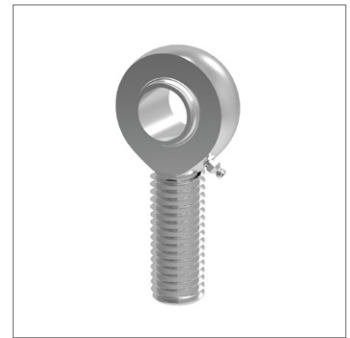
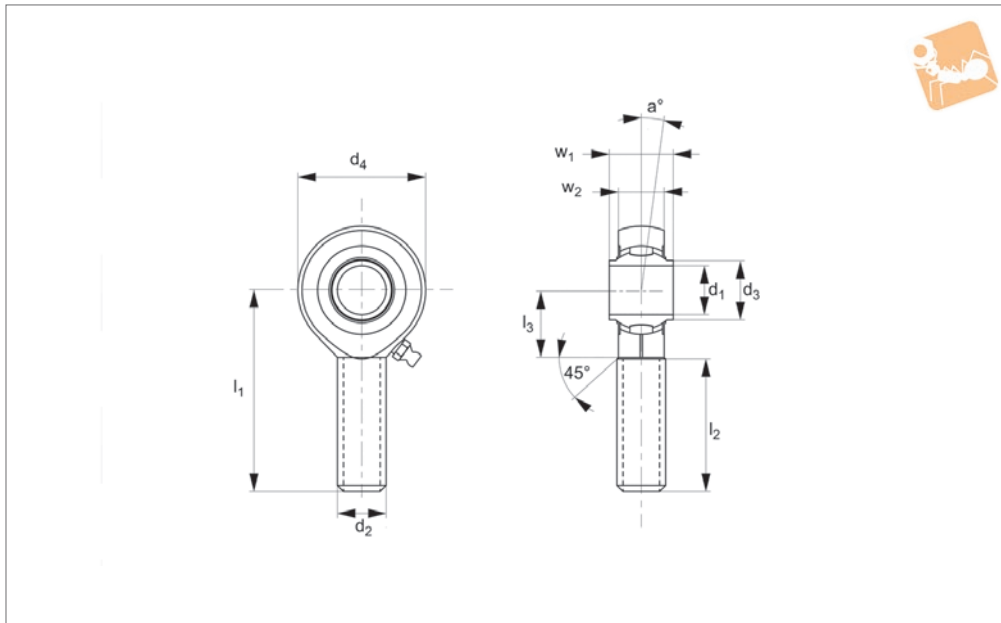

R3561

ROD ENDS

Material

Rod end housing - forged steel, tempered, case hardened bearing race, ground and lapped, surface galvanized.
Inner ring - ball bearing steel, hardened, superfine ground.
Lubrication - calcium-complex-soap-

grease, temp. range -20°C to +120°C, lubrication nipple - DIN 71412 HZ.

Technical Notes

Low maintenance. Sizes according to DIN ISO 12240-4, series K, for tolerances see technical pages.

Tips

Standard thread is right hand thread.

Important Notes

*Denotes fine pitch thread.

Order No.	Thread hand	d ₁	l ₁	d ₂	d ₃	l ₂	d ₄	a	Weight g
R3561.R012	Right	12	54	M12	14.5	33	32	7.5	88
R3561.R016	Right	16	66	M16	19.0	40	42	7.0	185
R3561.R020	Right	20	78	M20x1,5*	24.5	47	50	7.0	340
R3561.R025	Right	25	94	M24x2*	29.5	57	64	5.0	596
R3561.R030	Right	30	110	M30x2*	34.5	66	70	7.5	912
R3561.L012	Left	12	54	M12	14.5	33	32	7.5	88
R3561.L016	Left	16	66	M16	19.0	40	42	7.0	185
R3561.L020	Left	20	78	M20x1,5*	24.5	47	50	7.0	340
R3561.L025	Left	25	94	M24x2*	29.5	57	64	5.0	596
R3561.L030	Left	30	110	M30x2*	34.5	66	70	7.5	912

Order No.	l ₃	w ₁	w ₂	Dyn. load C kN max.	Speed rpm max.	Static load C ₀ kN max.
R3561.R012	19	16	12	10.25	1125	6.6
R3561.R016	22	21	15	13.3	975	8.9
R3561.R020	28	25	18	17.0	825	11.7
R3561.R025	30	31	22	24.90	600	18.5
R3561.R030	35	37	25	32.5	450	24.8
R3561.L012	19	16	12	10.25	1125	6.6
R3561.L016	22	21	15	13.3	975	8.9
R3561.L020	28	25	18	17.0	825	11.7
R3561.L025	30	31	22	24.9	600	18.5
R3561.L030	35	37	25	32.5	450	24.8

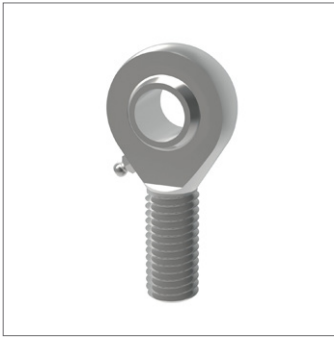

R3563

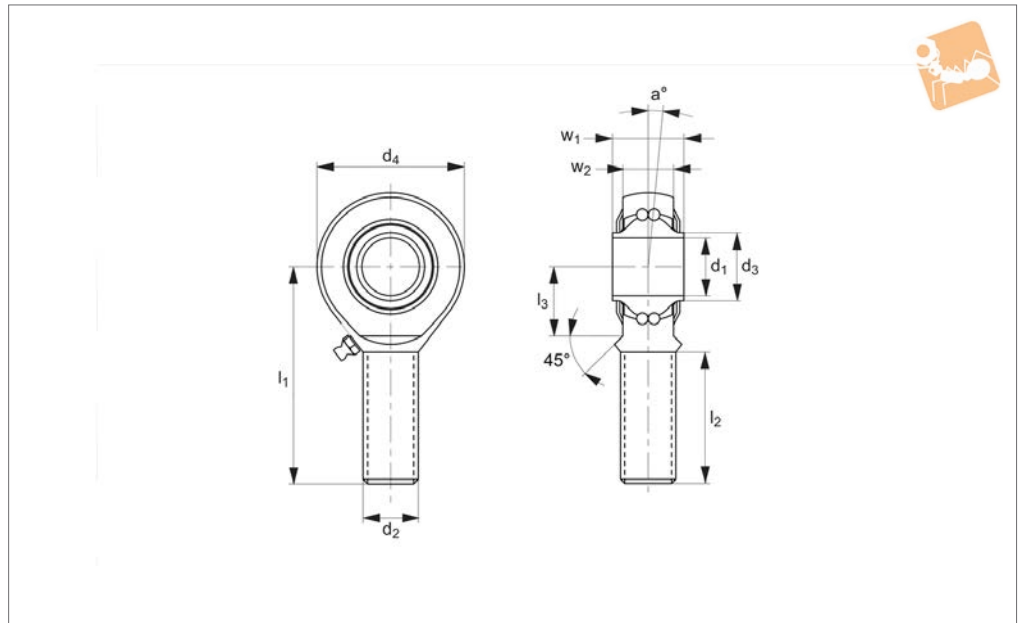

Material

Housing - stainless steel (AISI 304), forged, hardened bearing race, superfinished, rolled thread.

Inner ring - stainless steel (AISI 304), hardened, superfine finish.

Lubrication - aluminium-complex-soap-grease, temp range -45°C to +120°C.

Lubrication nipple - DIN 3405 D1/A (until size 10) DIN 71412 H1 (from size 12).

Technical Notes

Low maintenance, sizes according to DIN ISO 12240-4 series K, for tolerances see

technical pages.

Tips

Standard thread is right hand thread.

Important Notes

*Denotes fine pitch thread.

Order No.	Thread hand	d ₁	l ₁	d ₂	d ₃	l ₂	d ₄	a _°	l ₃	w ₁	Weight g
R3563.R008	Right	8	42	M8	10.5	25	24	8.5	15	12	36
R3563.R010	Right	10	48	M10	12.0	29	28	8.0	15	14	60
R3563.R012	Right	12	54	M12	14.5	33	32	7.5	19	16	87
R3563.R016	Right	16	66	M16	19.0	40	42	8.0	22	21	190
R3563.R020	Right	20	78	M20x1,5*	24.5	47	50	7.0	28	25	338
R3563.L008	Left	8	42	M8	10.5	25	24	8.5	15	12	36
R3563.L010	Left	10	48	M10	12.0	29	28	8.0	15	14	60
R3563.L012	Left	12	54	M12	14.5	33	32	7.5	19	16	87
R3563.L016	Left	16	66	M16	19.0	40	42	8.0	22	21	190
R3563.L020	Left	20	78	M20x1,5*	24.5	47	50	7.0	28	25	338

Order No.	w ₂	Calc. factor Y	Calc. factor Y ₀	Dyn. load C kN max.	Speed rpm max.	Static load C ₀ kN max.
R3563.R008	9.00	1.89	1.80	0.7	1300	2.8
R3563.R010	10.50	1.81	1.90	1.0	1225	3.1
R3563.R012	12.00	1.82	1.74	1.3	1125	3.5
R3563.R016	15.00	2.35	2.24	1.6	975	4.3
R3563.R020	18.00	2.58	2.46	2.3	825	5.4
R3563.L008	9.00	1.89	1.80	0.7	1300	2.8
R3563.L010	10.50	1.81	1.90	1.0	1225	3.1
R3563.L012	12.00	1.82	1.74	1.3	1125	3.5
R3563.L016	15.00	2.35	2.24	1.6	975	4.3
R3563.L020	18.00	2.58	2.46	2.3	825	5.4



Stainless Heavy-Duty Rod Ends - Male

with integral spherical plain bearing

Rod Ends

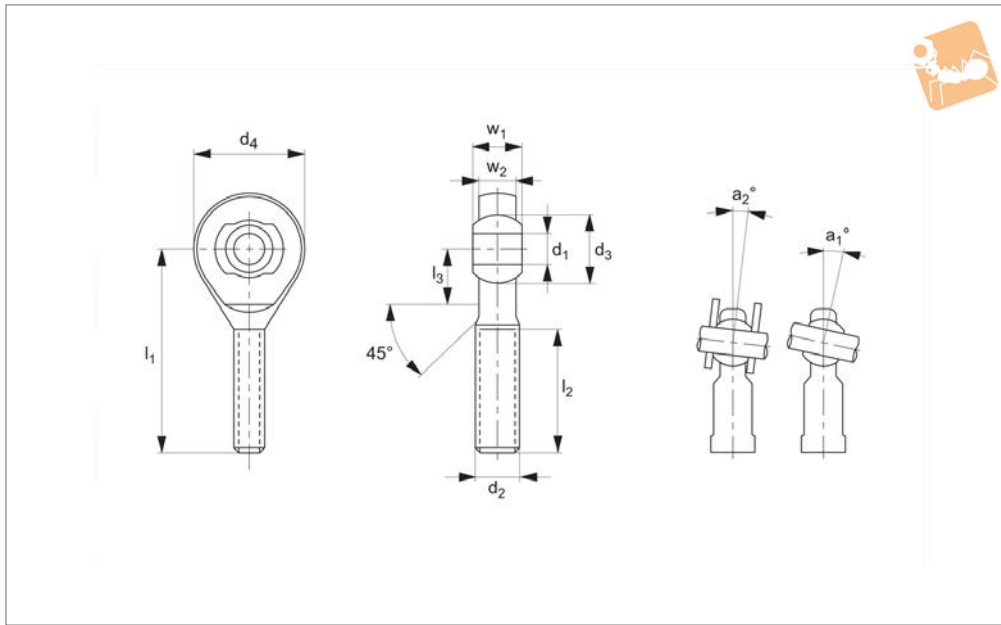

R3565

ROD ENDS

Material

Rod end housing: Stainless steel DIN 1.4301 (AISI 304), forged, rolled thread
 Joint ball: Stainless steel 1.4412, hardened and ground, surface polished.
 Race: Nylon/Teflon/glass compound.

Technical Notes

Maintenance free, for tolerances see technical

page 123, standard thread is right hand thread.

Tips

A2 stainless steel provides good corrosion resistance to a wide range of atmospheric conditions and corrosive media. It is considered resistant to potable water.

Important Notes

*Denotes fine pitch thread.

Order No.	Thread hand	d ₁	l ₁	d ₂	d ₃	l ₂	d ₄	a ₁ °	Weight g
R3565.R005	Right	5	33	M5	11.11	20	18	13.0	14
R3565.R006	Right	6	36	M6	12.70	22	20	13.0	20
R3565.R008	Right	8	42	M8	15.87	25	24	14.5	38
R3565.R010	Right	10	48	M10	19.05	29	28	13.5	60
R3565.R012	Right	12	54	M12	22.22	33	32	13.0	92
R3565.R014	Right	14	60	M14	25.40	36	36	16.0	127
R3565.R016	Right	16	66	M16	28.57	40	42	15.5	202
R3565.R018	Right	18	72	M18x1,5*	31.75	44	46	15.0	250
R3565.R020	Right	20	78	M20x1,5*	34.92	47	50	14.5	327
R3565.R022	Right	22	84	M22x1,5*	38.10	51	54	15.5	440
R3565.R025	Right	25	94	M24x2*	42.85	57	60	15.0	630
R3565.R030	Right	30	110	M30x2*	50.80	66	70	17.0	1015
R3565.L005	Left	5	33	M5	11.11	20	18	13.0	14
R3565.L006	Left	6	36	M6	12.70	22	20	13.0	20
R3565.L008	Left	8	42	M8	15.87	25	24	14.5	38
R3565.L010	Left	10	48	M10	19.05	29	28	13.5	60
R3565.L012	Left	12	54	M12	22.22	33	32	13.0	92
R3565.L014	Left	14	60	M14	25.40	36	36	16.0	127
R3565.L016	Left	16	66	M16	28.57	40	42	15.5	202
R3565.L018	Left	18	72	M18x1,5*	31.75	44	46	15.0	250
R3565.L020	Left	20	78	M20x1,5*	34.92	47	50	14.5	327
R3565.L022	Left	22	84	M22x1,5*	38.10	51	54	15.5	440
R3565.L025	Left	25	94	M24x2*	42.85	57	60	15.0	630
R3565.L030	Left	30	110	M30x2*	50.80	66	70	17.0	1015

Order No.	a ₂	l ₃	w ₁	w ₂	Dyn. load C ₀ kN max.	Static load C ₀ kN max.
R3565.R005	7.5	9	8	6.00	3.9	3.9



Order No.	a_2	l_3	w_1	w_2	Dyn. load C kN max.	Static load C_0 kN max.
R3565.R006	6.5	12	9	6.75	4.6	5.4
R3565.R008	7.5	15	12	9.00	7.0	9.7
R3565.R010	8.0	15	14	10.50	10.4	15.4
R3565.R012	8.0	19	16	12.00	12.4	22.3
R3565.R014	9.5	20	19	13.50	15.4	30.4
R3565.R016	8.5	22	21	15.00	22.4	41.5
R3565.R018	9.5	25	23	16.50	26.3	51.2
R3565.R020	9.0	28	25	18.00	30.8	60.3
R3565.R022	10.0	26	28	20.00	38.2	70.0
R3565.R025	10.0	30	31	22.00	45.4	87.0
R3565.R030	10.5	35	37	25.00	55.0	106.8
R3565.L005	7.5	9	8	6.00	3.9	3.9
R3565.L006	6.5	12	9	6.75	4.6	5.4
R3565.L008	7.5	15	12	9.00	7.0	9.7
R3565.L010	8.0	15	14	10.50	10.4	15.4
R3565.L012	8.0	19	16	12.00	12.4	22.3
R3565.L014	9.5	20	19	13.50	15.4	30.4
R3565.L016	8.5	22	21	15.00	22.4	41.5
R3565.L018	9.5	25	23	16.50	26.3	51.2
R3565.L020	9.0	28	25	18.00	30.8	60.3
R3565.L022	10.0	26	28	20.00	38.2	70.0
R3565.L025	10.0	30	31	22.00	45.4	87.0
R3565.L030	10.5	35	37	25.00	55.0	106.8



Stainless Heavy-Duty Rod Ends - Male with integral spherical plain bearing

Rod Ends

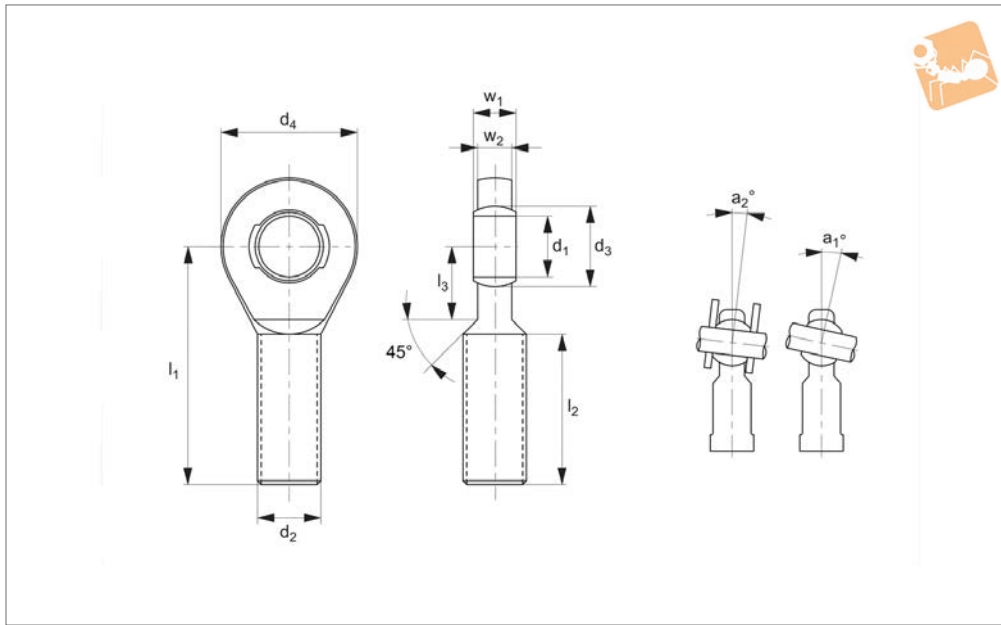

R3567

ROD ENDS

Material

Housing - stainless steel DIN 1.4301 (AISI 304), forged, rolled thread.

Joint ball - stainless steel DIN 1.4125 (AISI 440C), hardened and ground, polished

Race - polyamid-PTFE-fibreglass-

compound.

Technical Notes

Maintenance free, sizes according to DIN ISO 12240-4, series E, for tolerances technical pages.

Tips

Standard thread is right hand thread.

Important Notes

*denotes fine pitch thread.

Order No.	Thread hand	d ₁	l ₁	d ₂	d ₃	l ₂	d ₄	Weight g
R3567.R006	Right	6	36	M6	10.0	22	20	14
R3567.R008	Right	8	42	M8	13.0	25	23	24
R3567.R010	Right	10	48	M10	16.0	29	28	41
R3567.R012	Right	12	54	M12	18.0	33	32	67
R3567.R015	Right	15	63	M14	22.0	33	38	110
R3567.R017	Right	17	69	M16	25.0	40	44	163
R3567.R020	Right	24	78	M20x1,5*	29.0	47	51	270
R3567.R025	Right	25	94	M24x2*	35.5	57	62	508
R3567.R030	Right	30	110	M30x2*	40.7	66	70	785
R3567.R035	Right	35	140	M36x3*	47.0	92	82	1330
R3567.R040	Right	40	145	M42x3*	53.0	94	92	1890
R3567.R041	Right	40	150	M39x3*	53.0	99	92	1785
R3567.R045	Right	45	165	M45x3*	60.0	100	102	2620
R3567.R046	Right	45	163	M42x3*	60.0	98	102	2430
R3567.R050	Right	50	195	M52x3*	66.0	120	112	3865
R3567.R051	Right	50	185	M45x3*	66.0	110	112	3225
R3567.R060	Right	60	225	M60x4*	80.0	140	135	6400
R3567.R061	Right	60	210	M52x3*	80.0	125	135	5430
R3567.L006	Left	6	36	M6	10.0	22	20	14
R3567.L008	Left	8	42	M8	13.0	25	23	24
R3567.L010	Left	10	48	M10	16.0	29	28	41
R3567.L012	Left	12	54	M12	18.0	33	32	67
R3567.L015	Left	15	63	M14	22.0	33	38	110
R3567.L017	Left	17	69	M16	25.0	40	44	163
R3567.L020	Left	20	78	M20x1,5*	29.0	47	51	270
R3567.L025	Left	25	94	M24x2*	35.5	57	62	508
R3567.L030	Left	30	110	M30x2*	40.7	66	70	785
R3567.L035	Left	35	140	M36x3*	47.0	92	82	1330
R3567.L040	Left	40	145	M42x3*	53.0	94	92	1890
R3567.L041	Left	40	150	M39x3*	53.0	99	92	1785
R3567.L045	Left	45	165	M45x3*	60.0	100	102	2620
R3567.L046	Left	45	163	M42x3*	60.0	98	102	2430



Order No.	Thread hand	d ₁	l ₁	d ₂	d ₃	l ₂	d ₄	Weight g
R3567.L050	Left	50	195	M52x3*	66.0	120	112	3865
R3567.L051	Left	50	185	M45x3*	66.0	110	112	3225
R3567.L060	Left	60	225	M60x4*	80.0	140	135	6400
R3567.L061	Left	60	210	M52x3*	80.0	125	135	5430

Order No.	a°	l ₃	w ₁	w ₂	Dyn. load C kN max.	Static load C ₀ kN max.
R3567.R006	13.0	11	6	4	2.5	3.0
R3567.R008	15.0	12	8	5	4.2	5.0
R3567.R010	12.0	15	9	6	6.4	7.6
R3567.R012	10.5	15	10	7	9.2	10.4
R3567.R015	8.5	18	12	9	13.4	17.6
R3567.R017	10.0	23	14	10	19.2	24.3
R3567.R020	9.0	25	16	12	25.2	34.5
R3567.R025	7.5	32	20	16	42.4	53.6
R3567.R030	6.0	35	22	18	54.0	63.8
R3567.R035	6.5	38	25	20	70.4	81.4
R3567.R040	7.0	42	28	22	86.0	100.2
R3567.R041	7.0	42	28	22	86.0	100.2
R3567.R045	7.5	50	32	25	107.0	124.3
R3567.R046	7.5	50	32	25	107.0	124.3
R3567.R050	6.5	60	35	28	132.0	152.6
R3567.R051	6.5	60	35	28	132.0	152.6
R3567.R060	6.5	70	44	36	208.0	239.5
R3567.R061	6.5	70	44	36	208.0	239.5
R3567.L006	13.0	11	6	4	2.5	3.0
R3567.L008	15.0	12	8	5	4.2	5.0
R3567.L010	12.0	15	9	6	6.4	7.6
R3567.L012	10.5	15	10	7	9.2	10.4
R3567.L015	8.5	18	12	9	13.4	17.8
R3567.L017	10.0	23	14	10	19.2	24.3
R3567.L020	9.0	25	16	12	25.2	34.5
R3567.L025	7.5	32	20	16	42.4	53.6
R3567.L030	6.0	35	22	18	54.0	63.8
R3567.L035	6.5	38	25	20	70.4	81.4
R3567.L040	7.0	42	28	22	86.0	100.2
R3567.L041	7.0	42	28	22	86.0	100.2
R3567.L045	7.5	50	32	25	107.0	124.3
R3567.L046	7.5	50	32	25	107.0	124.3
R3567.L050	6.5	60	35	28	132.0	152.6
R3567.L051	6.5	60	35	28	132.0	152.6
R3567.L060	6.5	70	44	36	208.0	239.5
R3567.L061	6.5	70	44	36	208.0	239.5



Low Cost Rod End - Male

with teflon bearing race

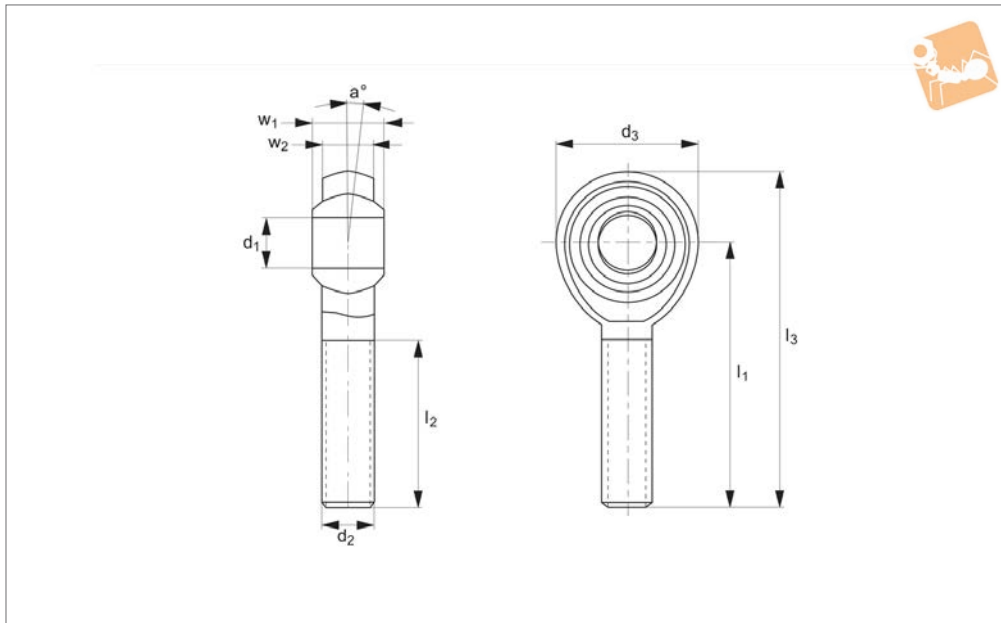

R3571

ROD ENDS

Material

Ball: low carbon steel, surface hardened.
 Silver zinc plated.
 Housing: low carbon steel, zinc plated for

corrosion resistance.
 Bearing race: teflon.
 Brass bearing with PTFE composite lining.

Technical Notes

Standard thread is right hand thread.

Order No.	Thread hand	d ₁ tol. H7	l ₁	d ₂	d ₃	l ₂	a°	l ₃	w ₁	w ₂	Static load C ₀ kN max.
R3571.R005	Right	5	33	M5	18	19	13	42	8	6.00	4.8
R3571.R006	Right	6	36	M6	20	21	13	46	9	6.75	6.2
R3571.R008	Right	8	42	M8	24	25	14	54	12	9.00	10.3
R3571.R010	Right	10	48	M10	28	28	13	62	14	10.50	14.4
R3571.R012	Right	12	54	M12	32	32	13	70	16	12.00	19.2
R3571.R016	Right	16	66	M16	42	37	15	87	21	15.00	31.2
R3571.L005	Left	5	33	M5	18	19	13	42	8	6.00	3.9
R3571.L006	Left	6	36	M6	20	21	13	46	9	6.75	6.0
R3571.L008	Left	8	42	M8	24	25	14	54	12	9.00	10.0
R3571.L010	Left	10	48	M10	28	28	13	62	14	10.50	16.0
R3571.L012	Left	12	54	M12	32	32	13	70	16	12.00	23.0
R3571.L016	Left	16	66	M16	42	37	15	87	21	15.00	44.0

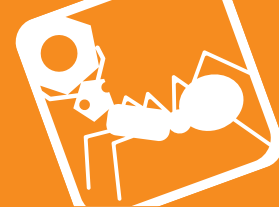

R3572.M

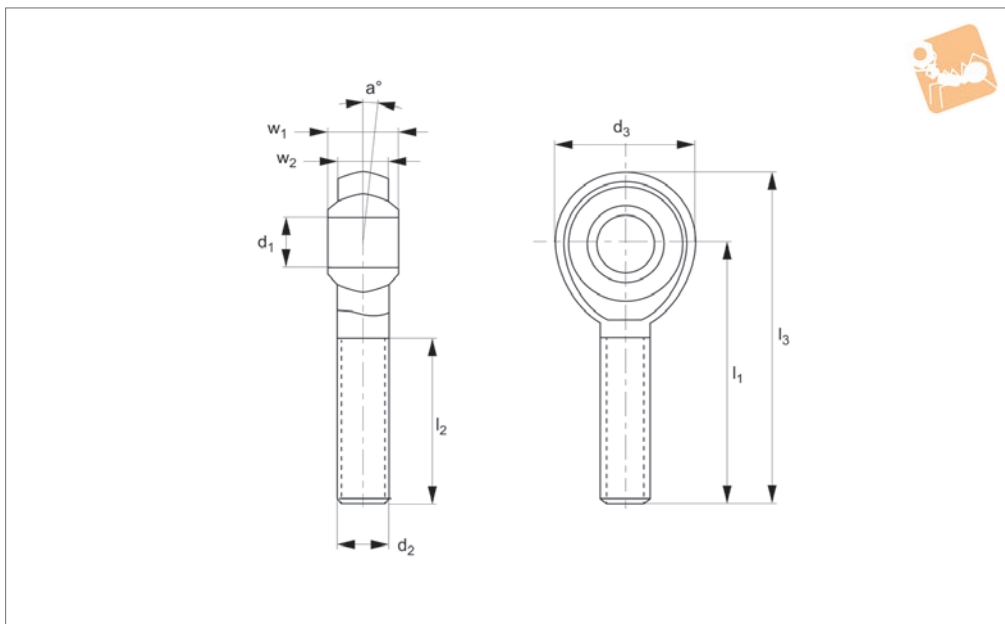

Material

Ball: low carbon steel, surface hardened.
Silver zinc plated.
Housing: low carbon steel, zinc plated for

corrosion resistance.

Technical Notes

Standard thread is right hand thread.

Order No.	Thread hand	d ₁ tol. H7	l ₁	d ₂	d ₃	l ₂	a°	l ₃	w ₁	w ₂	Static load C ₀ kN max.
R3572.MR005	Right	5	33	M 5	16	20	13	41	8	6.0	4.6
R3572.MR006	Right	6	36	M 6	18	22	13	45	9	6.75	5.8
R3572.MR008	Right	8	42	M 8	22	25	14	53	12	9.0	9.3
R3572.MR010	Right	10	48	M10	26	29	13	61	14	10.5	11.6
R3572.MR012	Right	12	54	M12	30	33	13	69	16	12.0	13.6
R3572.MR013	Right	12	54	M12x1,25	30	33	13	69	16	12.0	13.6
R3572.MR014	Right	14	60	M14	34	36	16	77	19	13.5	19.2
R3572.MR016	Right	16	66	M16	40	40	15	86	21	15.0	22.8
R3572.MR017	Right	16	66	M16x1,5	40	40	15	86	21	15.0	22.8
R3572.MR018	Right	18	72	M18x1,5	44	44	15	94	23	16.5	34.0
R3572.MR020	Right	20	78	M20x1,5	50	47	14	103	25	18.0	42.0
R3572.MR022	Right	22	84	M22x1,5	54	51	15	111	28	20.0	45.6
R3572.MR025	Right	25	94	M25x2	60	57	15	124	31	22.0	54.4
R3572.MR030	Right	30	110	M30x2	70	66	17	145	37	25.0	70.4



Low Cost Rod End - Male with integral spherical plain bearing

Rod Ends



R3573

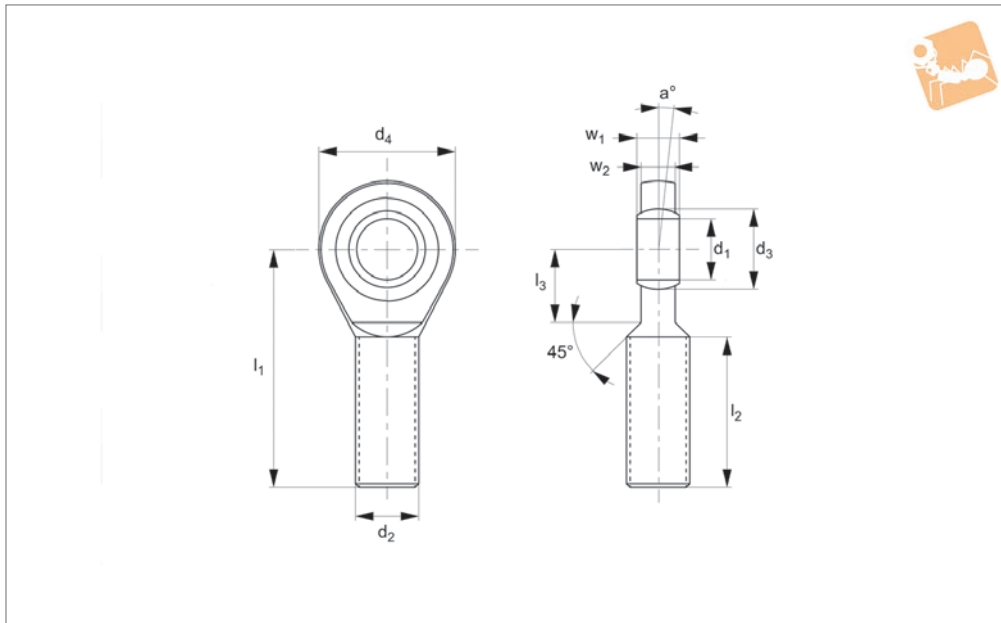

ROD ENDS

Material

Housing: Heat treated steel, surface galvanized, free of Cr VI. Outer ring: heat treated steel, hardened, single split, bonded with PTFE fabric. Joint Ball: Ball bearing steel, hardened, ground, polished up to size 12,

hard chromium plated.

Series E,
Maintenance free

Technical Notes

For tolerances see technical pages.
Standard thread is right hand thread.

Important Notes

*Denotes fine pitch thread.

Order No.	Thread hand	d ₁	l ₁	d ₂	d ₃	l ₂	d ₄	a°	l ₃	w ₁	w ₂	Static load C ₀ kN max.	Weight g
R3573.R006	Right	6	36	M6	10	18	21	13	12	6	4.4	6.6	17
R3573.R008	Right	8	42	M8	13	22	24	15	14	8	6	10.3	29
R3573.R010	Right	10	48	M10	16	26	29	12	15	9	7	14.1	51
R3573.R012	Right	12	54	M12	18	28	34	11	18	10	8	19.6	86
R3573.R015	Right	15	63	M14	22	34	40	8	20	12	10	28.8	140
R3573.R017	Right	17	69	M16	25	36	46	10	23	14	11	36.0	190
R3573.R020	Right	20	78	M20x1,5*	29	43	53	9	27	16	13	48.0	310
R3573.R025	Right	25	94	M24x2*	35.5	53	64	7	32	20	17	66.4	560
R3573.R030	Right	30	110	M30x2*	40.7	65	73	6	37	22	19	88	890
R3573.R035	Right	35	140	M36x3*	47	82	82	6	42	25	21	116.8	1400
R3573.R040	Right	40	150	M39x3*	53	86	92	7	48	28	23	144	1800
R3573.R041	Right	40	150	M42x3*	53	86	92	7	48	28	23	144	1850
R3573.R045	Right	45	163	M42x3*	60	94	102	7	52	32	27	192	2600
R3573.R046	Right	45	163	M45x3*	60	94	102	7	52	32	27	192	2660
R3573.R050	Right	50	185	M45x3*	66	107	112	6	60	35	30	232	3400
R3573.R051	Right	50	185	M52x3*	66	107	112	6	60	35	30	232	3500
R3573.R060	Right	60	210	M52x3*	80	115	135	6	75	44	38	360	5900
R3573.R061	Right	60	210	M60x4*	80	115	135	6	75	44	38	360	6020
R3573.R070	Right	70	235	M56x4*	92	125	160	6	87	49	42	488	8200
R3573.R071	Right	70	235	M72x4*	92	125	160	6	87	49	42	488	8380
R3573.R080	Right	80	270	M64x4*	105	140	180	6	100	55	47	600	12000
R3573.R081	Right	80	270	M80x4*	105	140	180	6	100	55	47	600	12200
R3573.L006	Left	6	36	M6	10	18	21	13	12	6	4.4	6.6	17
R3573.L008	Left	8	42	M8	13	22	24	15	14	8	6	10.3	29
R3573.L010	Left	10	48	M10	16	26	29	12	15	9	7	14.1	51
R3573.L012	Left	12	54	M12	18	28	34	11	18	10	8	19.6	86
R3573.L015	Left	15	63	M14	22	34	40	8	20	12	10	28.8	140
R3573.L017	Left	17	69	M16	25	36	46	10	23	14	11	36.0	190
R3573.L020	Left	20	78	M20x1,5*	29	43	53	9	27	16	13	48.0	310
R3573.L025	Left	25	94	M24x2*	35.5	53	64	7	32	20	17	66.4	560
R3573.L030	Left	30	110	M30x2*	40.7	65	73	6	37	22	19	88	890



Order No.	Thread hand	d ₁	l ₁	d ₂	d ₃	l ₂	d ₄	a °	l ₃	w ₁	w ₂	Static load C ₀ kN max.	Weight g
R3573.L035	Left	35	140	M36x3*	47	82	82	6	42	25	21	116.8	1400
R3573.L040	Left	40	150	M39x3*	53	86	92	7	48	28	23	144	1800
R3573.L041	Left	40	150	M42x3*	53	86	92	7	48	28	23	144	1850
R3573.L045	Left	45	163	M42x3*	60	94	102	7	52	32	27	192	2600
R3573.L046	Left	45	163	M45x3*	60	94	102	7	52	32	27	192	2660
R3573.L050	Left	50	185	M45x3*	66	107	112	6	60	35	30	232	3400
R3573.L051	Left	50	185	M52x3*	66	107	112	6	60	35	30	232	3500
R3573.L060	Left	60	210	M52x3*	80	115	135	6	75	44	38	360	5900
R3573.L061	Left	60	210	M60x4*	80	115	135	6	75	44	38	360	6020
R3573.L070	Left	70	235	M56x4*	92	125	160	6	87	49	42	488	8200
R3573.L071	Left	70	235	M72x4*	92	125	160	6	87	49	42	488	8380
R3573.L080	Left	80	270	M64x4*	105	140	180	6	100	55	47	600	12000
R3573.L081	Left	80	270	M80x4*	105	140	180	6	100	55	47	600	12200



Low Cost Rod End - Male

with integral spherical plain bearing



R3575.M

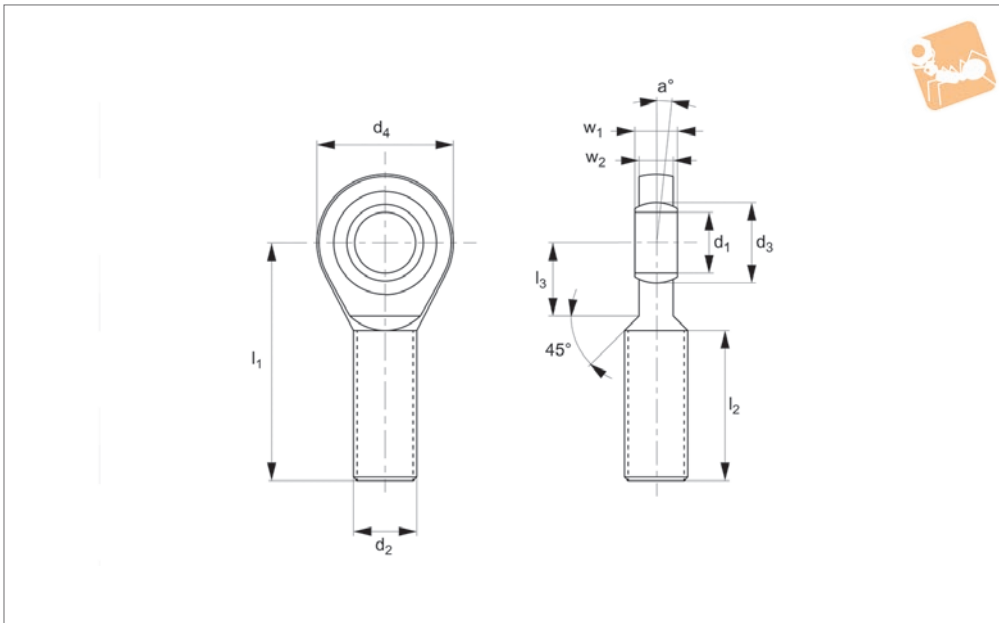

ROD ENDS

Material

Housing: Heat treated steel, surface galvanized, free of Cr VI. Outer ring: heat treated steel, hardened, single split, bonded with PTFE fabric.

Joint Ball: Ball bearing steel, hardened, ground, polished up to size 12, hard chromium plated.

Technical Notes

For tolerances see technical pages, main-

tenance required.

Tips

Standard thread is right hand thread.

Important Notes

*Denotes fine pitch thread.

Order No.	Thread hand	Type	d ₁ tol. H7	l ₁	d ₂	d ₃	l ₂	d ₄	a°	l ₃	w ₁	w ₂	Static load C ₀ kN max.	Weight g
R3575.MR006	Right	Male	6	36	M 6	10	18	21	13	12	6	4.4	6.6	17
R3575.MR008	Right	Male	8	42	M 8	13	22	24	15	14	8	6	10.3	29
R3575.MR010	Right	Male	10	48	M10	16	26	29	12	15	9	7	14.1	51
R3575.MR012	Right	Male	12	54	M12	18	28	34	11	18	10	8	19.6	86
R3575.MR015	Right	Male	15	63	M14	22	34	40	8	20	12	10	28.8	140
R3575.MR017	Right	Male	17	69	M16	25	36	46	10	23	14	11	36.0	190
R3575.MR020	Right	Male	20	78	M20x1,5*	29	43	53	9	27	16	13	48.0	310
R3575.MR025	Right	Male	25	94	M24x2*	35.5	53	64	7	32	20	17	66.4	560
R3575.MR030	Right	Male	30	110	M30x2*	40.7	65	73	6	37	22	19	88	890
R3575.MR035	Right	Male	35	140	M36x3*	47	82	82	6	42	25	21	116.8	1400
R3575.MR040	Right	Male	40	150	M39x3*	53	86	92	7	48	28	23	144	1800
R3575.MR041	Right	Male	40	150	M42x3*	53	86	92	7	48	28	23	144	1850
R3575.MR045	Right	Male	45	163	M42x3*	60	94	102	7	52	32	27	192	2600
R3575.MR046	Right	Male	45	163	M45x3*	60	94	102	7	52	32	27	192	2660
R3575.MR050	Right	Male	50	185	M45x3*	66	107	112	6	60	35	30	232	3400
R3575.MR051	Right	Male	50	185	M52x3*	66	107	112	6	60	35	30	232	3500
R3575.MR060	Right	Male	60	210	M52x3*	80	115	135	6	75	44	38	360	5900
R3575.MR061	Right	Male	60	210	M60x4*	80	115	135	6	75	44	38	360	6020
R3575.MR070	Right	Male	70	235	M56x4*	92	125	160	6	87	49	42	488	8200
R3575.MR071	Right	Male	70	235	M72x4*	92	125	160	6	87	49	42	488	8380
R3575.MR080	Right	Male	80	270	M64x4*	105	140	180	6	100	55	47	600	12000
R3575.MR081	Right	Male	80	270	M80x4*	105	140	180	6	100	55	47	600	12200



R3577.A2

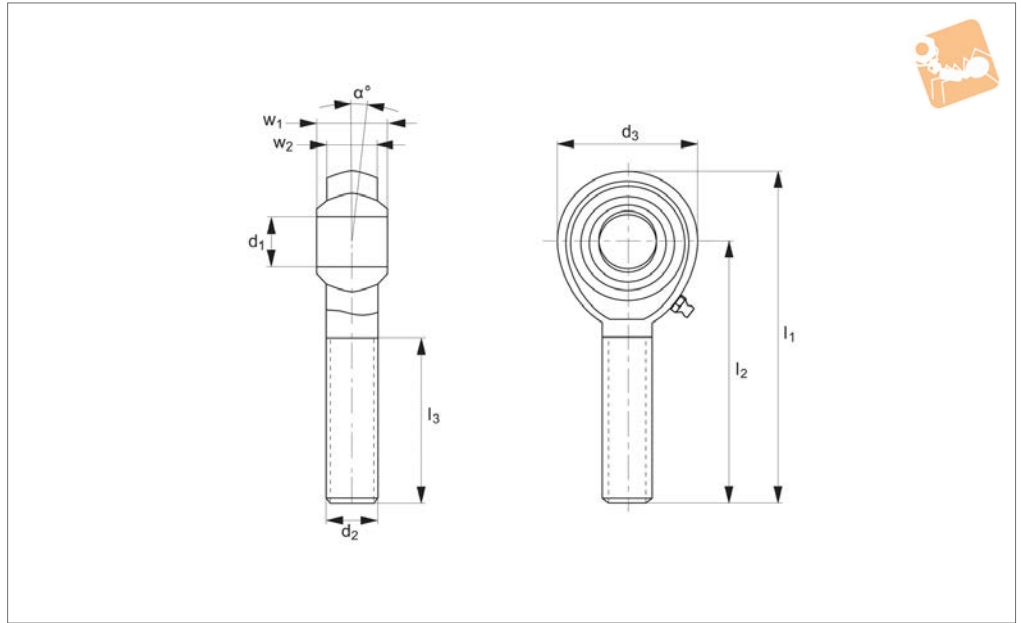

ROD ENDS

Material

Housing: stainless steel (AISI 303)

Ball: stainless steel, hardened, ground and polished.

Race: teflon or PTFE liner.

Stainless steel bearing ring lined with bronze and PTFE Composite

Technical Notes

Standard thread is right hand thread.

Order No.	Thread hand	d ₁ tol. H7	l ₁	d ₂	d ₃	l ₂	α°	l ₃	w ₁	w ₂	Static load kN max.	Weight g
R3577.R005-A2	Right	5	42	M5	18	33	13	19	8	6	4.8	13
R3577.R006-A2	Right	6	46	M6	20	36	13	21	9	6.75	6.2	20
R3577.R008-A2	Right	8	54	M8	24	42	14	25	12	9	10.3	38
R3577.R010-A2	Right	10	62	M10	28	48	13	28	14	10.50	14.4	55
R3577.R012-A2	Right	12	70	M12	32	54	13	32	16	12	19.2	85
R3577.R016-A2	Right	16	87	M16	42	66	15	37	21	15	31.2	210
R3577.L005-A2	Left	5	42	M5	18	33	13	19	8	6	4.8	13
R3577.L006-A2	Left	6	46	M6	20	36	13	21	9	6.75	5.2	20
R3577.L008-A2	Left	8	54	M8	24	42	14	25	12	9	7.0	38
R3577.L010-A2	Left	10	62	M10	28	48	13	28	14	10.50	10.4	55
R3577.L012-A2	Left	12	70	M12	32	54	13	32	16	12	13.0	85
R3577.L016-A2	Left	16	87	M16	42	66	15	37	21	15	31.2	210



Stainless Low Cost Rod Ends

A4 stainless steel

Rod Ends



R3577.A4

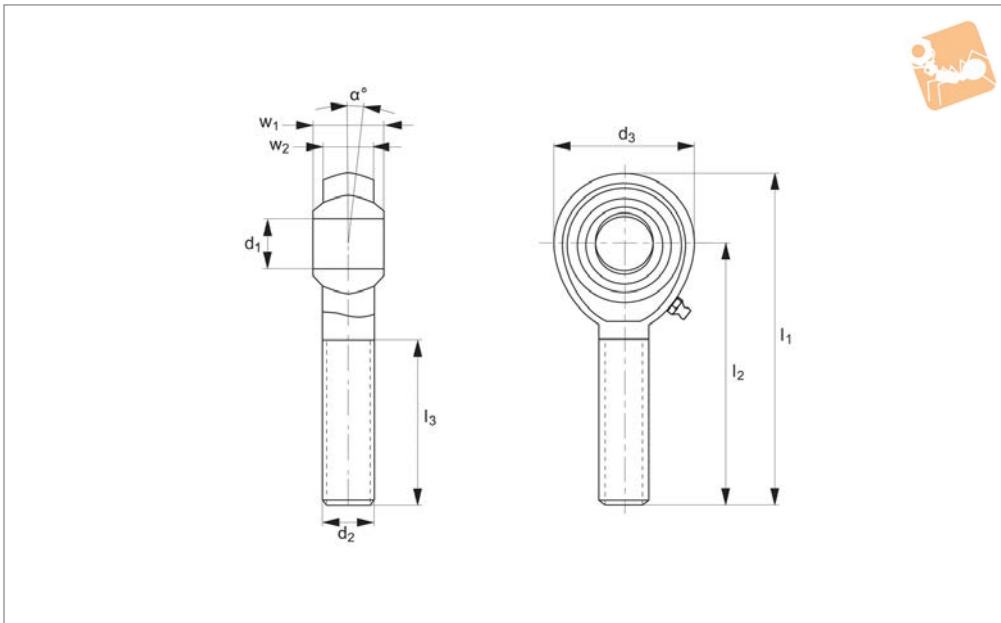

Material

Housing: stainless steel (AISI 316)
 Ball: stainless steel, 1,4571

Race: PTFE liner.

Technical Notes

Standard thread is right hand thread.

Order No.	Thread hand	d ₁ tol. H7	l ₁	d ₂	d ₃	l ₂	l ₃	w ₁	w ₂	α	Static load kN max.
R3577.R005-A4	Right	5	42	M 5	18	33	19	8	6.00	13	4.8
R3577.R006-A4	Right	6	46	M 6	20	36	21	9	6.75	13	6.2
R3577.R008-A4	Right	8	54	M 8	24	42	25	12	9.00	14	10.3
R3577.R010-A4	Right	10	62	M10	28	48	28	14	10.50	13	14.4
R3577.R012-A4	Right	12	70	M12	32	54	32	16	12.00	13	19.2
R3577.R016-A4	Right	16	87	M16	42	66	37	21	15.00	15	31.2
R3577.L005-A4	Left	5	42	M 5	18	33	19	8	6.00	13	4.8
R3577.L006-A4	Left	6	46	M 6	20	36	21	9	6.75	13	5.2
R3577.L008-A4	Left	8	54	M 8	24	42	25	12	9.00	14	7.0
R3577.L010-A4	Left	10	62	M10	28	48	28	14	10.50	13	10.4
R3577.L012-A4	Left	12	70	M12	32	54	32	16	12.00	13	13.0
R3577.L016-A4	Left	16	87	M16	42	66	37	21	15.00	15	31.2

ROD ENDS



R3580

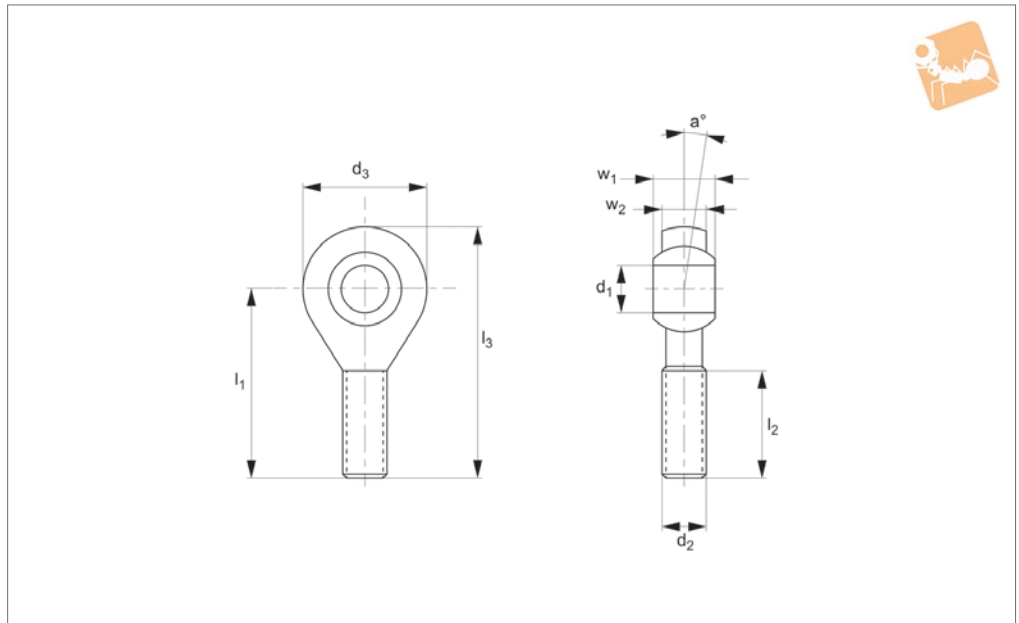

ROD ENDS

Material

Housing: Black plastic (Igumid G)
Spherical bearing: Iglidur W300.

Technical Notes

Resistant to dirt and dust, resistant to corrosion and chemicals.

High vibration dampening capacity

suitable for rotating, oscillating and linear movements.

Available with a metal sleeve to take a higher torque (Add -MS to part No.)
Standard thread is right hand thread.

Important Notes

Dimensional series K according to standard DIN ISO 12240. *Denotes fine pitch thread.
Short term max axial strength is up to 20 minutes. Any length of time greater than this is considered long term.

Order No.	Thread hand	d ₁ tol. E10	l ₁	d ₂	d ₃	l ₂	a°	l ₃	w ₁	w ₂	Radial load (long term) N max.
R3580.R005	Right	5	33	M5	18	19	15	42	8.0	6.0	40
R3580.R006	Right	6	36	M6	20	21	14.5	46	9.0	7.0	50
R3580.R008	Right	8	42	M8	24	25	12.5	55	12.0	9.0	100
R3580.R010	Right	10	48	M10	30	28	12.5	63	14.0	10.5	150
R3580.R011	Right	10	48	M10 x 1,25*	30	28	12.5	63	14.0	10.5	150
R3580.R012	Right	12	54	M12	34	32	12.5	71	16.0	12.0	200
R3580.R013	Right	12	54	M12 x 1,25*	34	32	12.5	71	16.0	12.0	200
R3580.R014	Right	14	61	M14	38	36	12.5	79	19.0	13.5	350
R3580.R016	Right	16	66	M16	42	37	11.5	88	21.0	15.0	400
R3580.R017	Right	16	66	M16 x 1,5*	42	37	11.5	88	21.0	15.0	400
R3580.R018	Right	18	72	M18 x 1,5*	46	41	11.5	96	23.0	16.5	500
R3580.R020	Right	20	78	M20 x 1,5*	50	45	11.5	104	25.0	18.0	650
R3580.R021	Right	20	78	M20 x 2,5	50	45	11.5	104	25.0	18.0	650
R3580.R022	Right	22	84	M22 x 1,5*	56	48	11	112	28.0	20.0	750
R3580.R025	Right	25	95	M24 x 2*	61	55	11	126	31.0	22.0	950
R3580.R030	Right	30	112	M30 x 2*	71	66	11	147	37.0	25.0	1150
R3580.L005	Left	5	33	M5	18	19	15	42	8.0	6.0	40
R3580.L006	Left	6	36	M6	20	21	14.5	46	9.0	7.0	50
R3580.L008	Left	8	42	M8	24	25	12.5	55	12.0	9.0	100
R3580.L010	Left	10	48	M10	30	28	12.5	63	14.0	10.5	150
R3580.L011	Left	10	48	M10 x 1,25*	30	28	12.5	63	14.0	10.5	150
R3580.L012	Left	12	54	M12	34	32	12.5	71	16.0	12.0	200
R3580.L013	Left	12	54	M12 x 1,25*	34	32	12.5	71	16.0	12.0	200
R3580.L014	Left	14	61	M14	38	36	12.5	79	19.0	13.5	350
R3580.L016	Left	16	66	M16	42	37	11.5	88	21.0	15.0	400
R3580.L017	Left	16	66	M16 x 1,5*	42	37	11.5	88	21.0	15.0	400
R3580.L018	Left	18	72	M18 x 1,5*	46	41	11.5	96	23.0	16.5	500
R3580.L020	Left	20	78	M20 x 1,5*	50	45	11.5	104	25.0	18.0	650
R3580.L021	Left	20	78	M20 x 2,5	50	45	11.5	104	25.0	18.0	650
R3580.L022	Left	22	84	M22 x 1,5*	56	48	11	112	28.0	20.0	750



Plastic Rod End Male

Rod Ends

Order No.	Thread hand	d ₁ tol. ±10	l ₁	d ₂	d ₃	l ₂	α	l ₃	w ₁	w ₂	Radial load (long term) N max.
R3580.L025	Left	25	95	M24 x 2*	61	55	11	126	31.0	22.0	950
R3580.L030	Left	30	112	M30 x 2*	71	66	11	147	37.0	25.0	1150

Order No.	Radial load (short term) N max.	Static strength (long term) N max.	Static strength (short term) N max.	Thread depth min.	Torque thread strength Nm max.	Torque through ball MS Nm max.	Torque through ball standard Nm max.
R3580.R005	80	400	800	13	0.4	12	5
R3580.R006	100	500	1000	15	0.5	15	10
R3580.R008	200	850	1700	18	2.0	40	12
R3580.R010	300	1250	2500	20	5.0	50	20
R3580.R011	300	1250	2500	20	3.0	50	20
R3580.R012	400	1350	2700	22	6.0	70	30
R3580.R013	400	1350	2700	22	6.0	70	30
R3580.R014	700	1700	3400	25	12.0	75	35
R3580.R016	800	1950	3900	26	17.0	110	40
R3580.R017	800	1950	3900	26	17.0	110	40
R3580.R018	1000	2100	4200	29	20.0	150	45
R3580.R020	1300	3000	6000	32	25.0	200	55
R3580.R021	1300	3000	6000	32	25.0	200	55
R3580.R022	1500	3600	7200	34	25.0	225	60
R3580.R025	1900	3750	7500	39	45.0	260	65
R3580.R030	2300	4400	8800	46	85.0	300	70
R3580.L005	80	400	800	13	0.4	12	5
R3580.L006	100	500	1000	15	0.5	15	10
R3580.L008	200	850	1700	18	2.0	40	12
R3580.L010	300	1250	2500	20	5.0	50	20
R3580.L011	300	1250	2500	20	3.0	50	20
R3580.L012	400	1350	2700	22	6.0	70	30
R3580.L013	400	1350	2700	22	6.0	70	30
R3580.L014	700	1700	3400	25	12.0	75	35
R3580.L016	800	1950	3900	26	17.0	110	40
R3580.L017	800	1950	3900	26	17.0	110	40
R3580.L018	1000	2100	4200	29	20.0	150	45
R3580.L020	1300	3000	6000	32	25.0	200	55
R3580.L021	1300	3000	6000	32	25.0	200	55
R3580.L022	1500	3600	7200	34	25.0	225	60
R3580.L025	1900	3750	7500	39	45.0	260	65
R3580.L030	2300	4400	8800	46	85.0	300	70

ROD ENDS



R3583

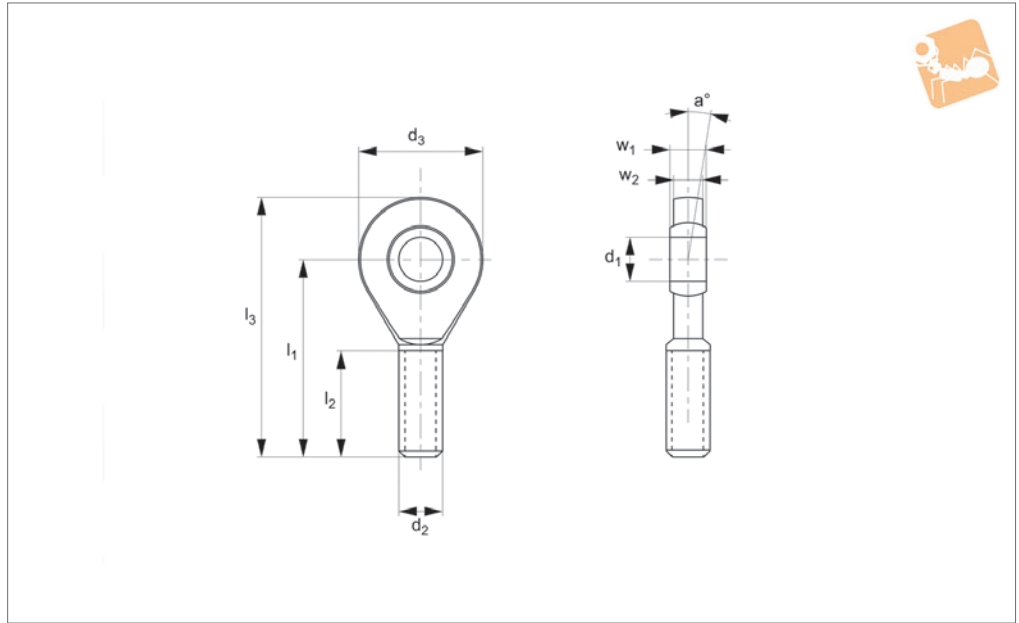

ROD ENDS

Material

Housing: Black plastic (Igumid G).
Spherical Bearing: Iglidur w300.

Technical Notes

Maintenance free, self lubricating. High strength under impact loads. Very high tensile strength for varying loads. Resistant to dirt and dust, resistant to

corrosion and chemicals, standard thread is right hand thread. High vibration dampening capacity, suitable for rotating, oscillating and linear movements. Available with a metal sleeve to take a higher torque, (add -MS to part No.) Suitable for use with R3409 clevis joints.

Important Notes

Dimensional series E. *Denotes fine pitch thread. Short term max axial strength is up to 20 minutes. Any length of time greater than this is considered long term.

Order No.	Thread hand	d ₁ tol. ±10	l ₁	d ₂	d ₃	l ₂	a°	l ₃	w ₁
R3583.R005	Right	5	36	M5	19	20	16.5	45.5	6
R3583.R006	Right	6	36	M6	21	20	13.5	46.5	6
R3583.R008	Right	8	41	M8	24	24	12	53.0	8
R3583.R010	Right	10	47.5	M10	29	27	12	62.0	9
R3583.R011	Right	10	47.5	M10 x 1,25*	9	27	12	62.0	9
R3583.R012	Right	12	54	M12	34	29	10.5	71.0	10
R3583.R013	Right	12	54	M12 x 1,25*	34	29	10.5	71.0	10
R3583.R015	Right	15	63	M14	40	34	10.5	83.0	12
R3583.R017	Right	17	69	M16	46	37	9	92.0	14
R3583.R018	Right	17	69	M16 x 1,5*	46	37	9	92.0	14
R3583.R020	Right	20	80	M20 x 1,5*	53	43	8	106.5	16
R3583.R021	Right	20	80	M20 x 2,5	53	53	8	106.5	16
R3583.R025	Right	25	97	M24 x 2*	64	53	8	129.0	20
R3583.R030	Right	30	113	M30 x 2*	73	65	12.5	149.5	22
R3583.L005	Left	5	36	M5	19	20	16.5	45.5	6
R3583.L006	Left	6	36	M6	21	20	13.5	46.5	6
R3583.L008	Left	8	41	M8	24	24	12	53.0	8
R3583.L010	Left	10	47.5	M10	29	27	12	62.0	9
R3583.L011	Left	10	47.5	M10 x 1,25*	9	27	12	62.0	9
R3583.L012	Left	12	54	M12	34	29	10.5	71.0	10
R3583.L013	Left	12	54	M12 x 1,25*	34	29	10.5	71.0	10
R3583.L015	Left	15	63	M14	40	34	10.5	83.0	12
R3583.L017	Left	17	69	M16	46	37	9	92.0	14
R3583.L018	Left	17	69	M16 x 1,5*	46	37	9	92.0	14
R3583.L020	Left	20	80	M20 x 1,5*	53	43	8	106.5	16
R3583.L021	Left	20	80	M20 x 2,5	53	53	8	106.5	16
R3583.L025	Left	25	97	M24 x 2*	64	53	8	129.0	20
R3583.L030	Left	30	113	M30 x 2*	73	65	6.5	149.5	22



Plastic Rod End Male

Rod Ends

Order No.	w ₂	Radial load (long term)		Radial load (short term)		Static strength (long term)		Static strength (short term)		Thread depth min.	Torque strength outside thread Nm max.	Torque through ball Nm max.
		N max.	N max.	N max.	N max.	N max.	N max.					
R3583.R005	4.4	25	50	275	550	14	0.4	2.0				
R3583.R006	4.4	40	80	425	850	14	0.5	2.5				
R3583.R008	6.0	80	160	800	1600	17	2.0	7.0				
R3583.R010	7.0	125	250	1300	2600	19	5.0	14.0				
R3583.R011	7.0	125	250	1300	2600	19	3.0	14.0				
R3583.R012	8.0	150	300	1550	3100	20	6.0	25.0				
R3583.R013	8.0	150	300	1550	3100	20	6.0	25.0				
R3583.R015	10.0	300	600	1700	3400	24	12.5	30.0				
R3583.R017	11.0	450	900	1800	3600	26	17.5	35.0				
R3583.R018	11.0	450	900	1800	3600	26	21.0	35.0				
R3583.R020	13.0	850	1700	3400	6800	30	25.0	40.0				
R3583.R021	13.0	850	1700	3400	6800	30	25.0	40.0				
R3583.R025	17.0	500	1000	3500	7000	37	45.0	55.0				
R3583.R030	19.0	1000	2000	3500	7000	46	85.0	70.0				
R3583.L005	4.4	25	50	275	550	14	0.4	2.0				
R3583.L006	4.4	40	80	425	850	14	0.5	2.5				
R3583.L008	6.0	80	160	800	1600	17	2.0	7.0				
R3583.L010	7.0	125	250	1300	2600	19	5.0	14.0				
R3583.L011	7.0	125	250	1300	2600	19	3.0	14.0				
R3583.L012	8.0	150	300	1550	3100	20	6.0	25.0				
R3583.L013	8.0	150	300	1550	3100	20	6.0	25.0				
R3583.L015	10.0	300	600	1700	3400	24	12.5	30.0				
R3583.L017	11.0	450	900	1800	3600	26	17.5	35.0				
R3583.L018	11.0	450	900	1800	3600	26	21.0	35.0				
R3583.L020	13.0	850	1700	3400	6800	30	25.0	40.0				
R3583.L021	13.0	850	1700	3400	6800	30	25.0	40.0				
R3583.L025	17.0	500	1000	3500	7000	37	45.0	55.0				
R3583.L030	19.0	1000	2000	3500	7000	46	85.0	70.0				

ROD ENDS



Pages 106 - 109

Heavy Duty Rod Ends - integral spherical plain bearing

Male and female series K rod ends, maintenance free. These are our most popular range of heavy duty rod ends.

Sizes Bore diameters 5mm up to 30mm.



Pages 110 - 113

Heavy Duty Rod Ends - integral spherical plain bearing

Male and female series E rod ends, maintenance free.

Sizes Bore diameters 6mm up to 60mm.



Pages 114 - 1120

Heavy Duty Rod Ends - integral ball bearing

Male and female series K rod ends. R3559 and R3560 have different bore sizes in relation to the thread size. All require maintenance.

Sizes Bore diameters 6mm up to 30mm.



Pages 121- 123

Heavy Duty Rod Ends - integral roller bearings

Male and female series E rod ends, require maintenance.

Sizes Bore diameters 12mm up to 30mm.



Pages 129 - 135

Stainless Steel Heavy Duty Rod Ends - integral spherical plain bearing

Male and female rod ends maintenance free. R3565 and R3566 K series rod ends, R3567 and R3568 E series rod ends.

Sizes R3565 and R3566 bore diameters 5mm up to 30mm. R3567 and R3568 bore diameters 6mm up to 60mm.



Pages 136 - 138

Low Cost Rod Ends - with spherical plain bearing

These are our most popular male and female rod ends. Maintenance free.

Sizes Female-bore diameters 5mm up to 12mm; Male-bore diameters 5mm up to 16mm.



Low Cost Rod Ends - spherical plain bearing

Male and female series E rod ends, maintenance free.

Sizes Bore diameters 6mm up to 80mm.



Pages 139 - 145

Stainless Steel Low Cost Rod Ends - spherical plain bearing

Male and Female Series K rod ends, maintenance free.

Sizes Bore diameters 5mm up to 20mm.



Pages 146 - 147

Plastic Rod Ends

Male and female rod ends, Series K and Series E rod ends.

Sizes Bore diameters 2mm up to 30mm.



Pages 150 - 157

Rod Ends with Studs

Steel and Stainless steel, male and female maintenance free.

Sizes M6 up to M16.



Pages 158 - 165

Hydraulic Rod Ends - spherical plain bearings

Various options from Weld on base through to female thread, require maintenance.

Sizes Bore diameters up to 160mm.

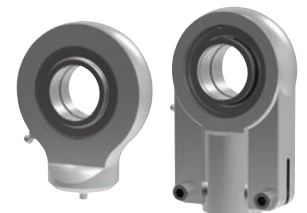

Pages 166 - 179

Spherical Plain Bearings - steel and stainless steel

Series K and series E spherical bearings. R3640 are our lowest cost, most popular option. R3641 and stainless steel R3642 require maintenance. R3640, R3644, and stainless steel R3645 are maintenance free.

Sizes Bore diameters 5mm up to 30mm.

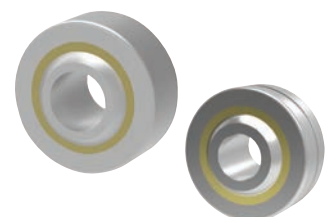

Pages 182 - 186



Rod ends with integral maintenance-free spherical plain bearings

In many cases heavy-duty rod ends with integral spherical plain bearings are most often used. They are above all used for small swivelling or tilting movements at low speeds. They stand out for their high load capacity and can also be used for shock-like loads. The rod end ball slides on a plastic bearing shell consisting of a glass fibre-filled nylon/teflon compound. This design assures a maintenance-free rod end. Heavy-duty plain bearing rod ends have slight initial movement friction and virtually no clearance. The plastic material used has another advantage in that it can absorb many foreign particles so that no damage can occur. The balls of heavy-duty rod ends with integral spherical plain bearings are hard chrome plated. This reliable corrosion protection ensures that the function of the rod end will not be affected by a corroded ball surface under humid operating conditions.

Rod ends with integral ball bearings

This design is especially suitable for high speeds, large swivelling angles or rotating movements with relatively low or medium loads. Prominent technical features are the low bearing friction, long-time greasing as well as the sealing against some dirt penetration (by means of shields on both sides). Under normal operating conditions the rod ends are maintenance-free.

Greasing nipples are provided for lubrication in case of rough operations and maximum loads. To avoid incompatibility with the production lubrication, we recommend lubrication with a calcium-complex-soap-grease. A special heat treatment procedure gives the rod end housing a raceway hardness adapted to the antifriction bearing, ensuring at the same time high stability with changing loads.

Rod ends with integral roller bearings

This design based on the structure of a self-aligning roller bearing is preferably used for high speed, large tilting angles or rotating movements under high loads. Compared to rod ends with ball bearings, rod ends with self-aligning roller bearings have essentially higher basic load ratings. This design is equipped with a cage to minimise the rolling friction and heat build-up. These rod ends, with long-time lubrication are under normal operating conditions maintenance-free.

Greasing nipples are provided for lubrication in case of rough operations and maximum loads. To avoid incompatibility with the production lubrication, we recommend lubricating with a calcium-complex-soap-grease.

Shields on both sides limit dirt particles from penetrating into the bearing. The rod ends with roller bearings are, subjected to a special heat treatment to obtain a raceway hardness adapted to the antifriction bearings, ensuring at the same time a high stability with changing loads.



Static load capacity C_0 (plain bearings)

The static load capacity C_0 is the radially acting static load which does not cause any permanent deformation of the components when the spherical bearing or rod end is stationary, (i.e. the load condition without pivoting, swivelling or tilting movements).

It is also a precondition here that the operating temperature must be at normal room temperature and the surrounding components must possess sufficient stability.

The values specified in the tables are determined by static tension tests on a representative number of series components at 20°C normal room temperature. The static load capacity may vary with lower or higher temperature depending on the material.

In the case of all rod ends with plain bearings, the static load rating refers to the maximum permissible static load of the rod end housing in a tensile direction up to which no permanent deformation occurs at the weakest housing cross-section. The value in the product tables has a safety factor of 1.2 times the tensile strength of the rod ends housing material.

Static load capacity C_0 (roller and ball bearings)

For our rod ends with roller and ball bearings, the static load rating is the load at which the bearing can operate at room temperature without its performance being impaired as a result of deformations, fracture, or damage to the sliding contact surfaces (max 1/10,000th of the ball diameter).

Dynamic load capacity C (plain bearings)

Dynamic load ratings serve as values for calculation of the service life of dynamically-loaded spherical bearings and rod ends. The values themselves do not provide any information about the effective dynamic load capacity of the spherical bearing or rod end. To obtain this information, it is necessary to take into account the additional influencing factors such as load type, swivel or tilt angle, speed characteristic, max. permitted bearing clearance, max. permitted bearing friction, lubrication conditions and temperature, etc.

Dynamic load capacities depend on the definition used to calculate them. Comparison of values is not always possible owing to the different definitions used by various manufacturers, and because the load capacities are often determined under completely different test conditions.

Dynamic load capacity C (roller and ball bearings)

For our rod ends with roller and ball bearings, the dynamic load capacity is the load at which 90% of a large quantity of identical rod ends reach 1 million revolutions before they fail (due to fatigue of the rolling surfaces).

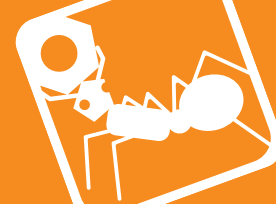
**Permissible load**

The maximum load is defined by the static basic load rating C_0 . If static loads are a combination of radial and axial loads, the equivalent static load will have to be calculated.

Permissible load:

$$P_0 \leq C_0 \text{ (N)}$$

Where: P_0 = Static equivalent load (kN)

Self-aligning ball bearing = $P_0 = F_r + Y_0 \cdot F_a$

Self-aligning roller bearing = $P_0 = F_r + 5 \cdot F_a$

F_a = Axial load

F_r = Radial load

Y_0 = Axial factor, static, see individual product pages

C_0 = Basic static load rating (kN), see individual product pages

Nominal service life

Rod Ends with integral self-aligning ball bearing R3556, R3557, R3559, R3560, R3563, R3564.

Rotating:

$$G_{h_{rot.}} = 10^6 \frac{\left(\frac{C}{P}\right)^3}{60 \cdot n} \text{ (h)}$$

Oscillating:

$$G_{h_{osc.}} = 10^6 \frac{\left(\frac{C}{P \sqrt[3]{\frac{\beta}{90}}}\right)^3}{60 \cdot f} \text{ (h)}$$

Where: P = Dynamic equivalent load (kN)

Self-aligning ball bearing = $P = F_r + Y \cdot F_a$

Self-aligning roller bearing = $P = F_r + 9.5 \cdot F_a$

C = Basic dynamic load (kN), see individual product pages

Y = axial factor, dynamic, see individual product pages

$G_{h_{rot.}}$ = nominal service life for rotation (hours of operation)

$G_{h_{osc.}}$ = nominal service life for rotation (hours of operation)

β = half of swivelling angle (degree), $\beta = 90$ should be used for rotation. **Condition:** Swivelling angle $\beta \leq 3^\circ$. For swivelling angles $\beta < 3^\circ$ we recommend the use of heavy-duty spherical plain bearing rod ends

n = rotation speed (rpm)

f = frequency of oscillation (rpm)

h = hours

Nominal service life

Rod ends with integral self-aligning roller bearing R3561, R3562.

Rotating:

$$G_{h_{rot.}} = 10^6 \frac{\left(\frac{C}{P}\right)^{3,333}}{60 \cdot n} \text{ (h)}$$

Oscillating:

$$G_{h_{osc.}} = 10^6 \frac{\left(\frac{C}{P \sqrt[3]{\frac{\beta}{90}}}\right)^{3,333}}{60 \cdot f} \text{ (h)}$$

See table on page 114 for key to symbols

Calculation example

At the rotating side of a crank mechanism a ball or roller bearing rod end should be installed. The expected service life amounts to at least 5000 hours.

Known: rotation speed $n = 300$ rpm, radial load $F_r = 0,75$ kN

Selected: R3557.R008 = 4,0 kN

$$\begin{aligned} G_{h_{rot.}} &= 10^6 \frac{\left(\frac{C}{P}\right)^3}{60 \cdot n} \\ &= 10^6 \frac{\left(\frac{4,0}{0,75}\right)^3}{60 \cdot 300} = \underline{\underline{8428 \text{ h} > 5000 \text{ h}}} \quad \checkmark \end{aligned}$$



Permissible load

The maximum permissible load is calculated by using equation 1. If static loads are a combination of radial and axial loads, the equivalent static load will have to be calculated using equation 2.

Permissible load:

Equation 1 $P_{max.} = C_0 \cdot C_2 \cdot C_4$

Equation 2 $P = F_r + F_a \leq P_{max.}$

- Where: P_{max} = Maximum permissible load (kN)
 C_0 = static basic load (kN), see individual product pages
 C_2 = Temperature factor, see below
 C_4 = Factor for type of load, see below
 P = Equivalent dynamic load (kN)
 F_r = Radial load
 F_a = Axial load (kN), **condition:** $F_a \leq 0.2 \cdot F_r$

Load factor C_4 :

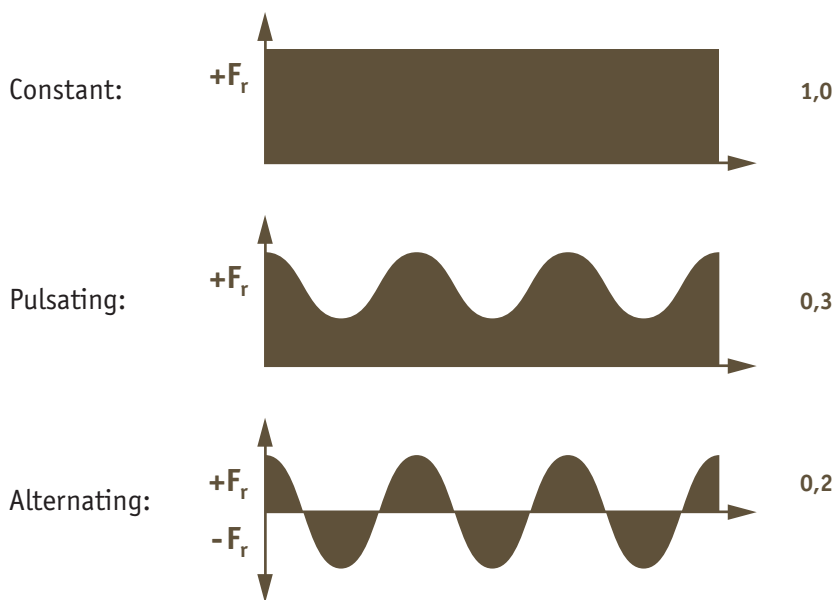

Temperature factor C_2 :

Up to 60°C	1,0
60°C to 80°C	0,8
80°C to 100°C	0,7
100°C to 120°C	0,8



Permissible sliding velocity

The permissible sliding velocity of heavy-duty rod ends mainly depends on the load and temperature conditions. Heat generated by friction in the rod end housing is the main limitation on sliding velocity. When selecting the rod end size, it is necessary to determine the sliding velocity and the pv-value, which is a product of the specific bearing load p (N/mm²) and the sliding velocity v (m/s).

Specific bearing load:

$$p = k \cdot \frac{P}{C}$$

Permissible pv-value = 0,5 N/mm² · m/s

- Where: P = Specific bearing load (N/mm²)
 C = Basic dynamic load rating (N), see individual product pages
 k = Specific load factor (N/mm²) for tribological pairing
 k = 50 N/mm²

Mean sliding velocity:

$$V_m = 5,82 \cdot 10^{-7} \cdot d_3 \cdot \beta \cdot f$$

Permissible sliding velocity $v_{max.} = 0,15$ m/s

- Where: V_m = Mean sliding velocity (m/s)
 d_3 = Pivot ball diameter (mm), see individual product pages
 β = Half swivelling angle (degree), for swivelling angle > 180°
 $\beta = 90^\circ$ to be used
 f = Frequency of oscillation (rpm)

Nominal service life:

$$G = C_1 \cdot C_2 \cdot C_3 \cdot \frac{3}{d_3 \cdot \beta} \cdot \frac{C}{P} \cdot 10^8$$

$$G_h = C_1 \cdot C_2 \cdot C_3 \cdot \frac{5}{d_3 \cdot \beta \cdot f} \cdot \frac{C}{P} \cdot 10^6$$

- Where: G = Nominal service life (number of oscillations or revolutions)
 G_h = Nominal service life (hours)
 C_1 = Load direction factor, see table on next page
 C_2 = Temperature factor, see previous page
 C_3 = Material factor, see alignment chart on next page



Where: C_1 = Load direction factor
 $C_1 = 1,0$ = Single load direction

Alternating load direction at $f < 30$ rpm: $C_1 = 0,250$

Alternating load direction at $f > 30$ rpm: $C_1 = 0,125$

Alignment:

To find C_3 calculate $C_2 \cdot \frac{C}{P}$ then using this value on the chart below, read across to C_3

Where: C_2 = Temperature factor
 C = basic dynamic load rating (N) see individual product pages
 P = Specific bearing load (N/mm²)

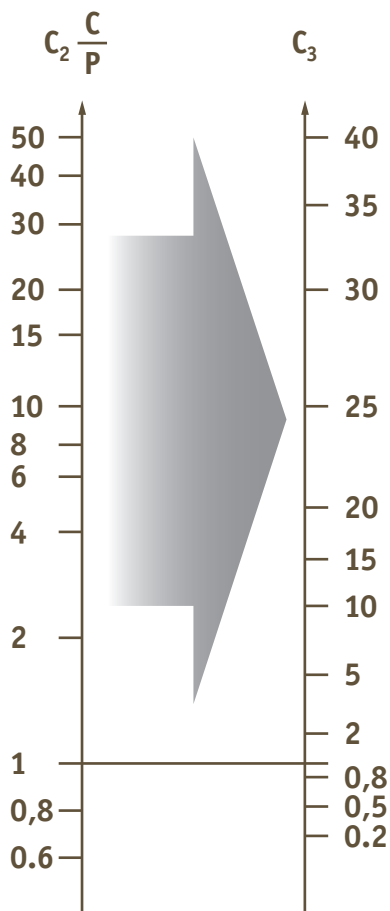

Calculation example

The rod end assembly of conveyor equipment calls for heavy-duty rod end with a service life of 7000 hours in conjunction with an alternating acting load of 5 kN. 25 swivelling moments with a swivelling angle of 20° take place per minute. The operating temperature amounts to approx. 60° C. The choice is a heavy-duty rod end R3554.R015 with: C = 13,4 kN, d₃ = 22mm.

Checking the permissible load of the rod end:

$$P_{\max.} = C_0 \cdot C_2 \cdot C_4$$

$$P_{\max.} = 41 \cdot 0,2 \cdot 1,0 = 8,2 \text{ kN} > 5,0 \text{ kN}$$

Where: C₀ = 41 kN
 C₂ = 1,0 (temperature 60° C)
 C₄ = 0,2 (alternating load)

Checking the permissible sliding velocity:

$$V_m = 5,82 \cdot 10^{-7} \cdot d_3 \cdot \beta \cdot f = 5,82 \cdot 10^{-7} \cdot 22 \cdot 10 \cdot 25$$

$$= \underline{0,0032 \text{ m/s} < 0,15 \text{ m/s}} \quad \checkmark$$

Checking the p · V-value:

$$pV = p \cdot V_m$$

$$pV = 18,66 \cdot 0,0032$$

$$= 0,06 \text{ N/mm}^2 \cdot \text{m/s} < 0,5 \text{ N/mm}^2 \cdot \text{m/s} \quad \checkmark$$

$$p = k \cdot \frac{P}{C} = 50 \cdot \frac{5000}{13400} = 18,66 \text{ N/mm}^2$$

Nominal service life:

$$G_h = C_1 \cdot C_2 \cdot C_3 \cdot \frac{5}{d_3 \cdot \beta \cdot f} \cdot \frac{C}{P} \cdot 10^6$$

$$G_h = 0,25 \cdot 1,0 \cdot 12 \cdot \frac{5}{22 \cdot 10 \cdot 25} \cdot \frac{13,4}{5,0} \cdot 10^6$$

$$= \underline{7308 \text{ h} > 7000 \text{ h}} \quad \checkmark$$

Where: C₁ = 0,25 (alternating load direction, f = 25 rpm < 30 rpm)

$$C_3 = C_2 \cdot \frac{C}{P} = 1,0 \cdot \frac{13,4}{5,0} = 2,68$$

See alignment chart (on page 118) C₃ = 12

Where: d₃ = 22
 f = 25 rpm
 β = 10° (half the swivelling angle 20° = 10°)
 C = 13,4 kN
 P = 5,0 kN



Low cost rod ends load ratings

The ultimate radial static load rating is measured as the failure point when a load is increasingly applied to a pin through the rod end's bore and pulled straight up while the rod end is held in place. Note that the actual rating is determined by calculating the lowest of the following three values:

1: Raceway material comprehensive strength (R value):

$$R = E \times T \times X$$

2: Rod end head strength (H value, cartridge type construction):

$$H = \left[\left(\frac{T}{2} \sqrt{D^2 - T^2} \right) + \left(\frac{D^2}{2} \times \sin^{-1} \frac{T}{2} \right) - (\text{O.D. of Bearing} \times T) \right] \times X$$

Angle of $\frac{T}{2}$ expressed in radians

3: Shank strength (S Value) male threaded rod end:

$$S = [(\text{root diameter of thread}^2 \times .78) - (N^2 \times .78)] \times X$$

female threaded rod end:

$$S_2 = [(J^2 \times .78) + (\text{major diameter of thread} \times .78)] \times X$$

- Where: E = Ball diameter
 T = Housing width
 X = Allowable stress
 D = Head diameter
 N = Diameter of drilled hole in shank of male rod end
 J = Shank diameter of female rod end

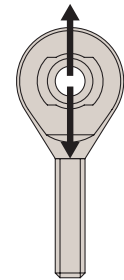

The axial static load capacity is measured as the force required to cause failure via a load parallel to the axis of the bore. Depending on the material types and construction methods, the ultimate axial load is generally 10-20% of the ultimate radial static load. The formula does not account for the bending of the shank due to a moment of force, nor the strength of the stake in cartridge-type construction.

Axial strength (A Value):

$$A = .78 [(E + .176T)^2 - E^2] \times X$$

- Where: X = Allowable stress (see table below)
 E = Ball diameter
 T = Housing width

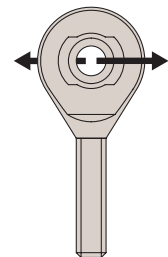

Material	Allowable stress (PSI)
300 Series Stainless Steel	35,000
Low Carbon Steel	52,000

Operating temperatures

Heavy-duty ball and roller bearing rod ends can be used for operating temperatures between -20°C and $+120^{\circ}\text{C}$. The temperature range of heavy-duty rod ends with integral spherical plain bearing is between -30°C and $+60^{\circ}\text{C}$, without affecting the load capacity. Higher temperatures will reduce the load capacity taken into account for the calculation of the 'working life' under the temperature factor C_2 on page 116.

Loads

The decisive parameters for the selection and calculation of heavy-duty rod ends are size, direction and type of load.

Radial or combined loads

The heavy-duty rod ends have been especially designed to cope with high radial loads. They can be used for combined loads, the axial load share of which does not exceed 20% of the corresponding radial load.

Unilaterally acting load

In this case the load acts only in the same direction, which means that the load area is always in the same bearing section.

Alternately acting load

In case of alternating loads, the load areas facing each other are alternately loaded and/or relieved, which means that the load changes its direction constantly by approximately 180° .

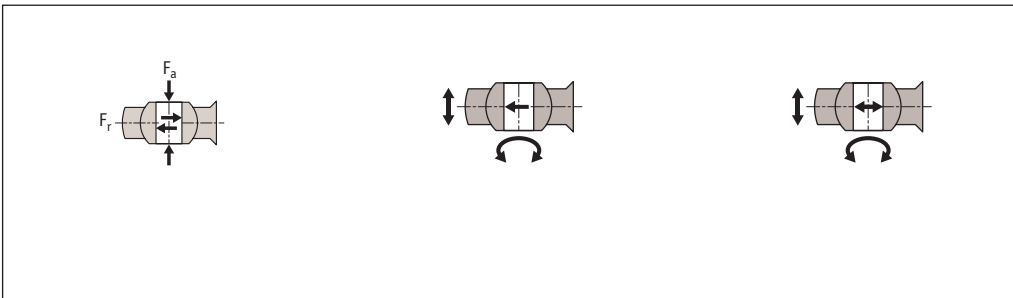

Swivelling angle

The swivelling angle is the movement of the rod end from one final position to the other. Half the swivelling angle α° is used to calculate the service or 'working life'.

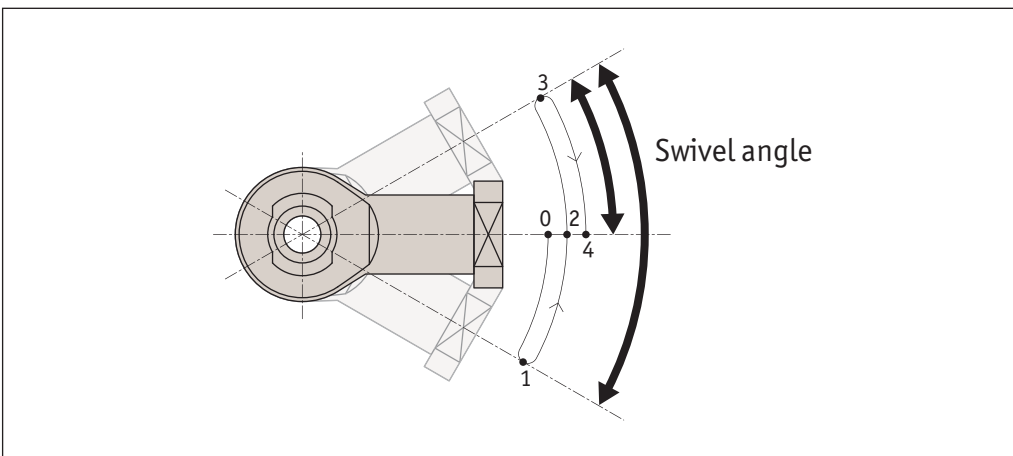



Angle of tilt

The angle of tilt, also called setting angle, refers to the movement of the joint ball and/or the inner ring to the rod end axis (in degrees). The tilting angle (a) indicated in the table for the heavy-duty ball and roller bearing rod ends corresponds to the maximum possible movement being limited by the shields on both sides. It is important that this tilting angle is not exceeded either during installation or operation, as otherwise the shields may be damaged. For heavy-duty plain bearing rod ends a distinction is made between the tilting angles (a_1 and a_2).

If the movement is not limited by adjacent components, then angle a_1 can fully be used without affecting the rod end capacity. Tilting angle a_2 is the movement limit when connecting a forked component.

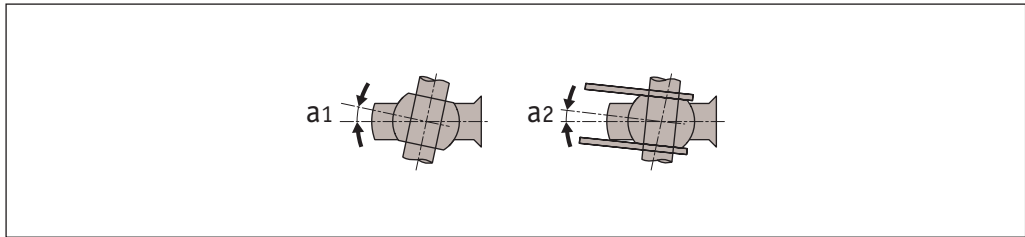

Nominal service life

The term 'nominal service life' is used for heavy-duty ball and roller bearing rod ends and represents the number of swivelling motions or rotations and/or the number of service hours the rod end performs before showing the first signs of material fatigue on the raceway or roller bodies. In view of many factors that are difficult or impossible to assess, the service life of several apparently identical bearings differ under the same operating conditions.

For this reason, the following method for the service life determination of heavy-duty ball and roller rod ends results in a nominal service life being achieved or exceeded by at least 90% of a large quantity of identical rod ends.

Working life

The term 'working life' is used with heavy-duty plain bearing rod ends. It represents the number of swivelling motions or rotations and/ or the number of service hours the heavy duty plain bearing rod end performs before becoming unserviceable due to material fatigue, wear, increased bearing clearance or increase of the bearing friction moment.

The 'working life' is not only influenced by the size and the type of load, it is also affected by a number of factors, which are difficult to assess. A calculation of the exact service life is therefore impossible. Field-experienced standard values for the approximate 'working life' can nevertheless be determined by using the following calculation procedure which is based on numerous results from endurance test runs and values from decades of experience. The values determined by this formula are achieved, if not exceeded, by the majority of the heavy-duty rod ends.

Heavy-duty rod ends (R3550, R3551, R3556, R3557, R3561, R3562, R3563, R3564, R3565, R3566, R3610, R3611, R3613, R3614)

d1		d1mp Tolerance Limit		V _{d1p}	V _{d1mp}	b1s Tolerance Limit		hs, h1s, h2s Tolerance Limit	
over	icl.	upper	lower	max.	max.	upper	lower	upper	lower
	6	+0,012	0	0,012	0,009	0	-0,12	+0,8	-1,2
6	10	+0,015	0	0,015	0,011	0	-0,12	+0,8	-1,2
10	18	+0,018	0	0,018	0,014	0	-0,12	+1,0	-1,7
18	30	+0,021	0	0,021	0,016	0	-0,12	+1,4	-2,1
30	50	+0,025	0	0,025	0,019	0	-0,12	+1,8	-2,7

Heavy-duty rod ends (R3553, R3554, R3559, R3560, R3567, R3568)

d1		d1mp Tolerance Limit		V _{d1p}	V _{d1mp}	b1s Tolerance Limit		hs, h1s, h2s Tolerance Limit	
over	icl.	upper	lower	max.	max.	upper	lower	upper	lower
	10	0	-0,008	0,008	0,006	0	-0,12	+0,8	-1,2
10	18	0	-0,008	0,008	0,006	0	-0,12	+0,8	-1,2
18	30	0	-0,010	0,010	0,008	0	-0,12	+1,0	-1,7
30	50	0	-0,012	0,012	0,009	0	-0,12	+1,4	-2,1
50	80	0	-0,015	0,015	0,011	0	-0,15	+1,8	-2,7

Dimensions and tolerance symbols

- d₁ = nominal bore diameter of the inner ring or joint ball.
- d_{1mp} = mean bore diameter deviation in one plane, arithmetical mean of the largest and smallest bore diameter.
- V_{d1p} = bore diameter variation in one plane, difference between the largest and smallest bore diameter.
- V_{d1mp} = mean bore diameter variation, difference between the largest and smallest bore diameter of one inner ring or joint ball.
- b_{1s} = single inner ring or joint ball width deviation.
- h, h₁, h₂ = single length from inner ring or ball bore centre to shank end.
- h_s, h_{1s}, h_{2s} = single length variation of a single rod end.



Load

The load capacity of the maintenance free bearing element parts is very high at normal ambient temperatures. These bearings absorb high forces and weigh only one fifth of traditional, metal bearing housings. The excellent dampening properties are based on the fact that the polymer material of the two part bearing can absorb vibrations differently than steel.

However, plastic specific properties, such as dependence on temperature and behaviour under long term stress must be taken into consideration when using these bearings.

The load capacity of the rod end bearing should therefore be checked in a practical test, particularly if it will be used under continuous high loads and at elevated temperatures.

Chemical resistance

The moisture absorption is approximately 1.3% of weight in standard atmosphere.

The saturation limit in water is 6.5%. This must be taken into account for these types of applications. The housing made of igumid G is resistant to weak alkalines, acids and fuels, as well as all types of lubricants.

Medium	Resistance
Alcohol	+ to 0
Hydrocarbons	+
Greases, oils without additives	+
Fuels	+
Diluted acids	0 to -
Strong acids	-
Diluted alkalines	+
Strong alkalines	0

Chemical resistance of plain bearings.

+ resistant

0 conditionally resistant

- not resistant.

All data given at room temperature (20°C).

Radiation resistance

Self aligning plain bearings are resistant to radiation up to an intensity of 3×10^2 Gy.

Application temperatures

These bearings can be used in temperatures from -30°C to $+80^\circ\text{C}$. The table below shows the effect of temperature on the load capacity of the bearings.

Minimum	-30°C
Maximum, long term	-80°C
Maximum, short term	$+120^\circ\text{C}$

Coefficients of sliding friction and speed

One important advantage of plastic spherical bearings is that rapid, rotary movements of a mounted shaft take place directly in the spherical portion. In metallic rod ends, rotary motion takes place between the race and the spherical bearing. High speeds can be achieved with plastic bearings.

These bearings are used in such a way that the angular movements of the spherical bearings take place at the outer diameter. By contrast, rotations of the shaft are supported directly in the I.D. of the spherical portion. The advantage therefore lies in the polymer vs. steel relationship. Polymer produces lower friction and permits high speeds, even when running dry.

UV resistance

The corrosion resistance of these bearings makes them very useful for outside applications. They are permanently resistant to UV radiation. A small change in colour (dark colouration) of the spherical ball due to UV radiation does not affect the mechanical electrical or thermal properties.

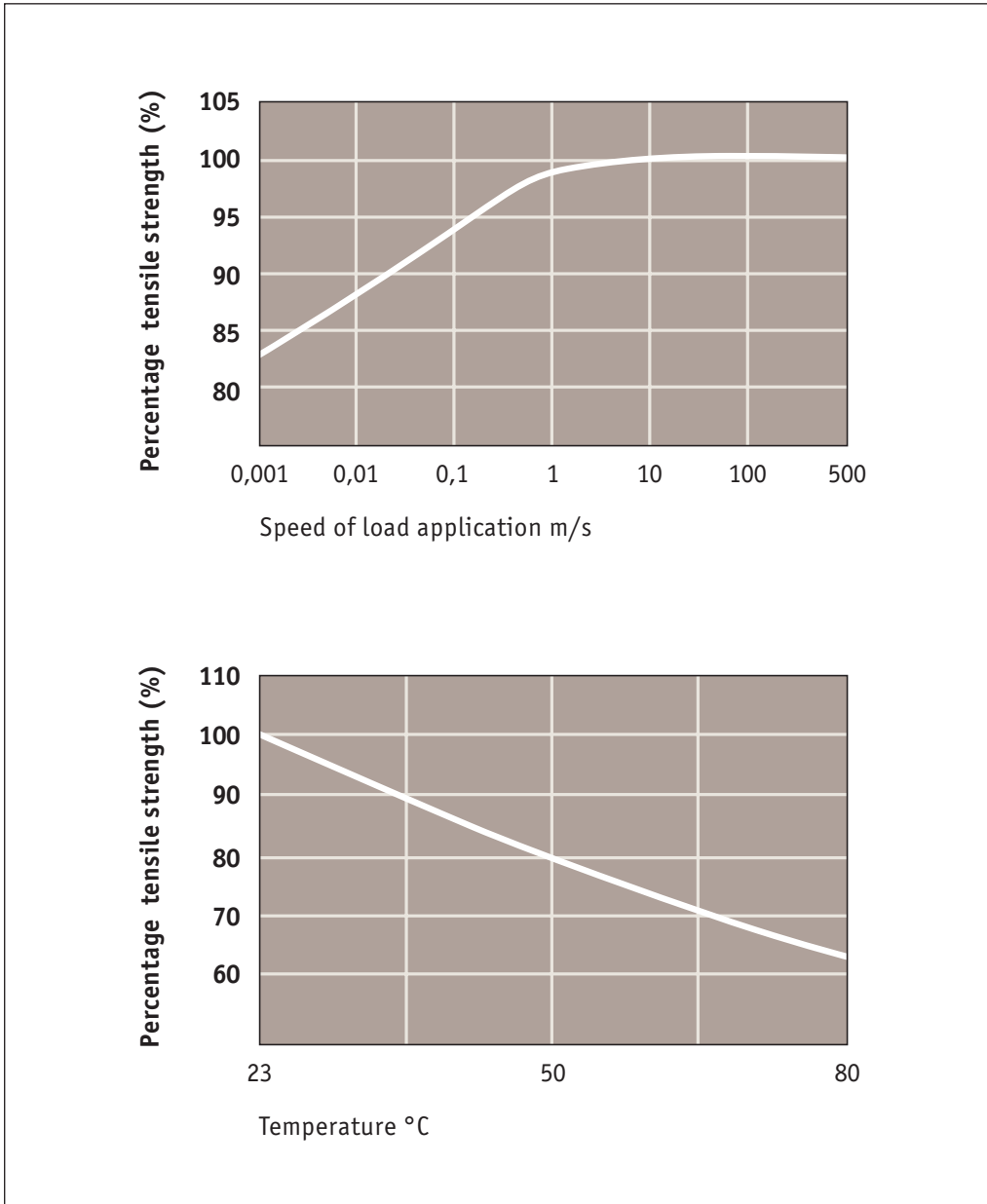

Rod Ends from Automation Components

ROD ENDS

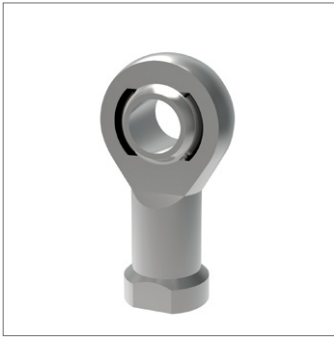

R3551

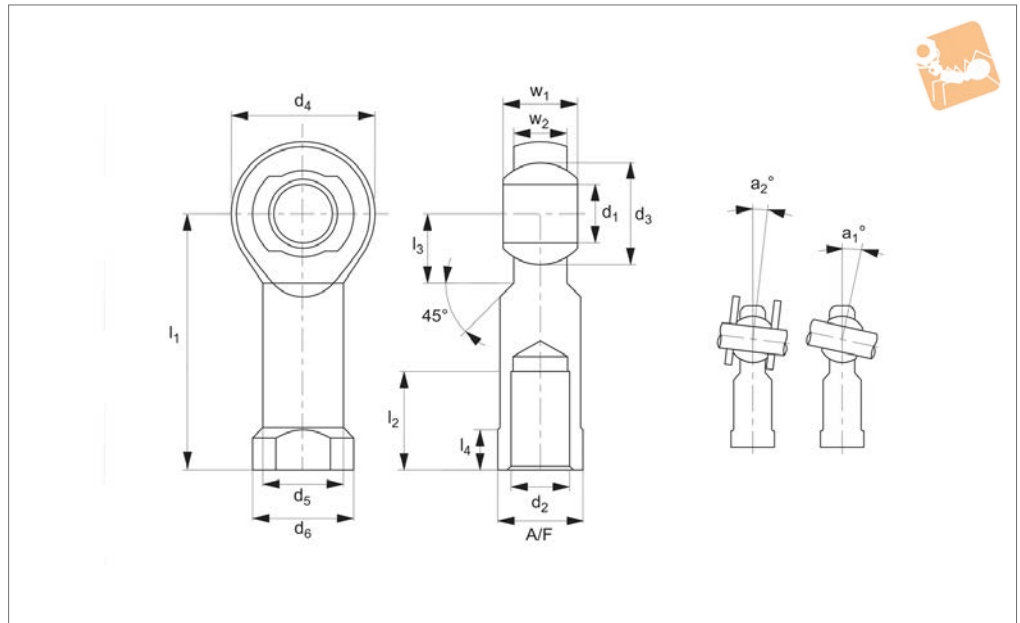

Material

Rod end housing - forged steel, tempered, surface galvanized.

Joint ball - ball bearing steel, hardened and ground, polished and chromium plated.

Race - nylon/teflon/glass compound.

Technical Notes

Maintenance free, sizes according to DIN ISO 12240-4, series K, thread according to Cetop RP 103 P.

For tolerances see technical pages.

Tips

Standard thread is right hand thread.

Important Notes

* Denotes fine pitch thread.

Order No.	Thread hand	d ₁	l ₁	d ₂	d ₃	d ₄	d ₅	d ₆	l ₂	Weight g
R3551.R004	Right	5	27	M4	11.11	18	9.0	11	10	18
R3551.R005	Right	5	27	M5	11.11	18	9.0	11	10	18
R3551.R006	Right	6	30	M6	12.70	20	10.0	13	12	24
R3551.R008	Right	8	36	M8	15.87	24	12.5	16	16	45
R3551.R010	Right	10	43	M10	19.05	28	15.0	19	20	74
R3551.R011	Right	10	43	M10x1,25*	19.05	28	15.0	19	20	74
R3551.R012	Right	12	50	M12	22.22	32	17.5	22	22	109
R3551.R013	Right	12	50	M12x1,25*	22.22	32	17.5	22	22	109
R3551.R014	Right	14	57	M14	25.40	36	20.0	25	25	155
R3551.R016	Right	16	64	M16	28.57	42	22.0	27	28	233
R3551.R017	Right	16	64	M16x1,5*	28.57	42	22.0	27	28	233
R3551.R018	Right	18	71	M18x1,5*	31.75	46	25.0	31	32	310
R3551.R020	Right	20	77	M20x1,5*	34.92	50	27.5	34	33	386
R3551.R022	Right	22	84	M22x1,5*	38.10	54	30.0	38	37	520
R3551.R025	Right	25	94	M24x2*	42.85	60	33.5	42	42	705
R3551.R030	Right	30	110	M30x2*	50.80	70	40.0	50	51	1084
R3551.R031	Right	30	110	M27x2*	50.80	70	40.0	50	51	1084
R3551.L004	Left	5	27	M4	11.11	18	9.0	11	10	18
R3551.L005	Left	5	27	M5	11.11	18	9.0	11	10	18
R3551.L006	Left	6	30	M6	12.70	20	10.0	13	12	24
R3551.L008	Left	8	36	M8	15.87	24	12.5	16	16	45
R3551.L010	Left	10	43	M10	19.05	28	15.0	19	20	74
R3551.L011	Left	10	43	M10x1,25*	19.05	28	15.0	19	20	74
R3551.L012	Left	12	50	M12	22.22	32	17.5	22	22	109
R3551.L013	Left	12	50	M12x1,25*	22.22	32	17.5	22	22	109
R3551.L014	Left	14	57	M14	25.40	36	20.0	25	25	155
R3551.L016	Left	16	64	M16	28.57	42	22.0	27	28	233
R3551.L017	Left	16	64	M16x1,5*	28.57	42	22.0	27	28	233
R3551.L018	Left	18	71	M18x1,5*	31.75	46	25.0	31	32	310
R3551.L020	Left	20	77	M20x1,5*	34.92	50	27.5	34	33	386
R3551.L022	Left	22	84	M22x1,5*	38.10	54	30.0	38	37	520
R3551.L025	Left	25	94	M24x2*	42.85	60	33.5	42	42	705



Heavy-Duty Rod Ends - Female

with integral spherical plain bearing

Rod Ends

Order No.	Thread hand	d ₁	l ₁	d ₂	d ₃	d ₄	d ₅	d ₆	l ₂	Weight g
R3551.L030	Left	30	110	M30x2*	50.80	70	40.0	50	51	1084
R3551.L031	Left	30	110	M27x2*	50.80	70	40.0	50	51	1084

Order No.	l ₃	l ₄	w ₁	w ₂	A/F	a ₁	a ₂	Dyn. load C kN max.	Static load C ₀ kN max.
R3551.R004	10	4.0	8	6.00	9	13.0	7.5	3.91	10.8
R3551.R005	10	4.0	8	6.00	9	13.0	7.5	3.91	10.8
R3551.R006	12	5.0	9	6.75	11	13.0	6.5	4.59	12.8
R3551.R008	12	5.0	12	9.00	14	14.5	7.5	6.965	19.2
R3551.R010	15	6.5	14	10.50	17	13.5	8.0	10.42	27.4
R3551.R011	15	6.5	14	10.50	17	13.5	8.0	10.42	27.4
R3551.R012	16	6.5	16	12.00	19	13.0	8.0	12.42	33.4
R3551.R013	16	6.5	16	12.00	19	13.0	8.0	12.42	33.4
R3551.R014	20	8.0	19	13.50	22	16.0	9.5	15.44	41.3
R3551.R016	22	8.0	21	15.00	22	15.5	8.5	22.41	59.6
R3551.R017	22	8.0	21	15.00	22	15.5	8.5	22.41	59.6
R3551.R018	24	10.0	23	16.50	27	15.0	9.5	26.32	69.7
R3551.R020	26	10.0	25	18.00	30	14.5	9.0	30.80	82.2
R3551.R022	26	12.0	28	20.00	32	15.5	10.0	38.23	95.60
R3551.R025	30	12.0	31	22.00	36	15.0	10.0	45.35	118.6
R3551.R030	35	15.0	37	25.00	41	17.0	10.5	55.01	145.6
R3551.R031	35	15.0	37	25.00	41	17.0	10.5	55.01	145.6
R3551.L004	10	4.0	8	6.00	9	13.0	7.5	3.91	10.8
R3551.L005	10	4.0	8	6.00	9	13.0	7.5	3.91	10.8
R3551.L006	12	5.0	9	6.75	11	13.0	6.5	4.59	12.8
R3551.L008	12	5.0	12	9.00	14	14.5	7.5	6.965	19.2
R3551.L010	15	6.5	14	10.50	17	13.5	8.0	10.42	27.4
R3551.L011	15	6.5	14	10.50	17	13.5	8.0	10.42	27.4
R3551.L012	16	6.5	16	12.00	19	13.0	8.0	12.42	33.4
R3551.L013	16	6.5	16	12.00	19	13.0	8.0	12.42	33.4
R3551.L014	20	8.0	19	13.50	22	16.0	9.5	15.44	41.3
R3551.L016	22	8.0	21	15.00	22	15.5	8.5	22.41	59.6
R3551.L017	22	8.0	21	15.00	22	15.5	8.5	22.41	59.6
R3551.L018	24	10.0	23	16.50	27	15.0	9.5	26.32	69.7
R3551.L020	26	10.0	25	18.00	30	14.5	9.0	30.80	82.2
R3551.L022	26	12.0	28	20.00	32	15.5	10.0	38.23	95.6
R3551.L025	30	12.0	31	22.00	36	15.0	10.0	45.35	118.6
R3551.L030	35	15.0	37	25.00	41	17.0	10.5	55.01	145.6
R3551.L031	35	15.0	37	25.00	41	17.0	10.5	55.01	145.6

ROD ENDS

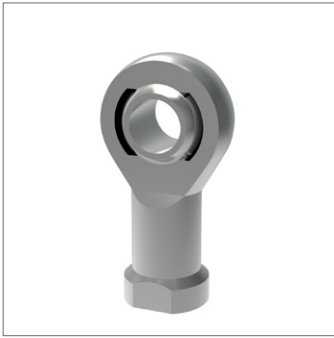

R3551.i

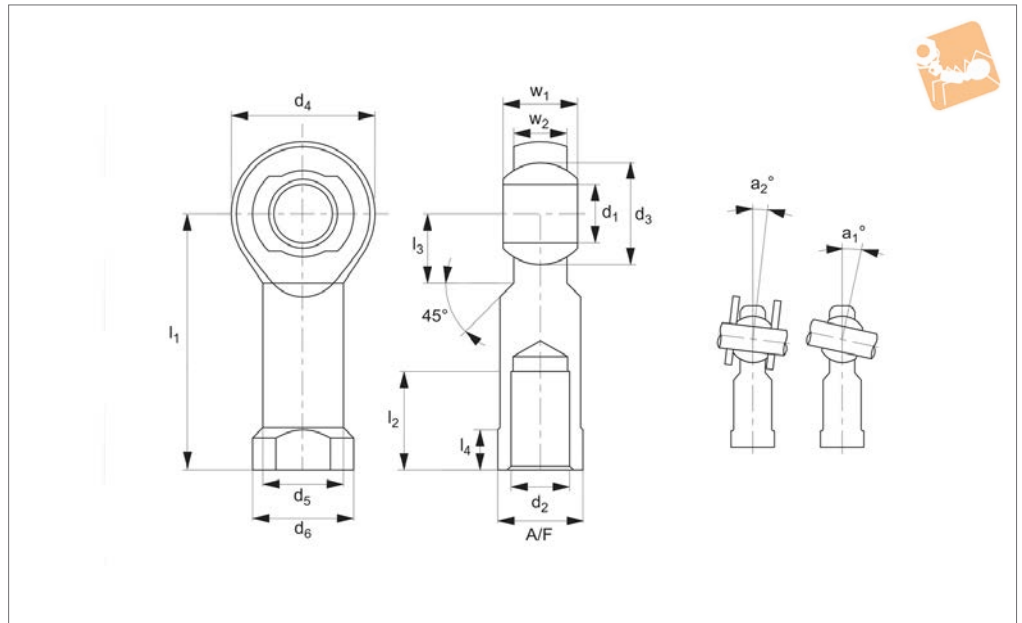

Material

Rod end housing - forged steel, tempered, surface galvanized.

Joint ball - ball bearing steel, hardened and ground, polished and chromium

plated.

Race - nylon/teflon/glass compound.

Technical Notes

Female thread maintenance free adapter

sizes according to DIN ISO 12240-4, series K, thread according to Cetop RP 103P.

Tips

Standard thread is right hand thread.

Order No.	Thread hand	d ₁	l ₁	d ₂	d ₃	d ₄	d ₅	d ₆	Weight g
R3551.i250	Right	0.250	1.338	1/4-28	0.516	0.750	0.374	0.469	27
R3551.i375	Right	0.375	1.641	3/8-24	0.719	1.000	0.567	0.689	59
R3551.i500	Right	0.500	2.145	1/2-20	0.876	1.311	0.748	0.874	127
R3551.i625	Right	0.625	2.539	5/8-18	1.125	1.653	0.866	1.063	231
R3551.i750	Right	0.625	2.905	3/4-16	1.249	1.750	1.000	1.126	229
R3551.i1000	Right	1.000	3.720	1-12	1.688	2.362	1.319	1.654	663
R3551.i1001	Right	1.000	3.720	1-14	1.688	2.362	1.319	1.654	663
R3551.iL250	Left	0.250	1.338	1/4-28	0.516	0.750	0.374	0.469	27
R3551.iL375	Left	0.375	1.641	3/8-24	0.719	1.000	0.567	0.689	59
R3551.iL500	Left	0.500	2.145	1/2-20	0.876	1.311	0.748	0.874	127
R3551.iL625	Left	0.625	2.539	5/8-18	1.125	1.653	0.866	1.063	231
R3551.iL750	Left	0.625	2.905	3/4-16	1.249	1.750	1.000	1.126	229
R3551.iL1000	Left	1.000	3.720	1-12	1.688	2.362	1.319	1.654	663
R3551.iL1001	Left	1.000	3.720	1-14	1.688	2.362	1.319	1.654	663

Order No.	l ₂	l ₃	l ₄	l ₅	w ₁	w ₂	A/F	a ₀	Dyn. load C kN max.	Static load C ₀ kN max.
R3551.i250	0.716	0.385	0.185	1.713	0.374	0.283	0.381	17.5	4.3	12.5
R3551.i375	0.847	0.503	0.275	2.141	0.499	0.405	0.570	9.5	7.7	22.3
R3551.i500	1.161	0.649	0.279	2.801	0.624	0.472	0.757	13.0	14.7	42.9
R3551.i625	1.102	0.885	0.350	3.366	0.826	0.590	0.866	15.5	22.4	59.6
R3551.i750	1.718	0.854	0.311	3.780	0.874	0.688	1.007	11.0	24.9	66.2
R3551.i1000	1.653	1.200	0.511	4.901	1.220	0.866	1.417	15.5	45.4	118.6
R3551.i1001	1.653	1.200	0.511	4.901	1.220	0.866	1.417	15.5	45.4	118.6
R3551.iL250	0.716	0.385	0.185	1.713	0.374	0.283	0.381	17.5	4.3	12.5
R3551.iL375	0.847	0.503	0.275	2.141	0.499	0.405	0.570	9.5	7.7	22.3
R3551.iL500	1.161	0.649	0.279	2.801	0.624	0.472	0.757	13.0	14.7	42.9
R3551.iL625	1.102	0.885	0.350	3.366	0.826	0.590	0.866	15.5	22.4	59.6
R3551.iL750	1.718	0.854	0.311	3.780	0.874	0.688	1.007	11.0	24.9	66.2
R3551.iL1000	1.653	1.200	0.511	4.901	1.220	0.866	1.417	15.5	45.4	118.6
R3551.iL1001	1.653	1.200	0.511	4.901	1.220	0.866	1.417	15.5	45.4	118.6



Heavy-Duty Rod Ends - Female

with integral spherical plain bearing

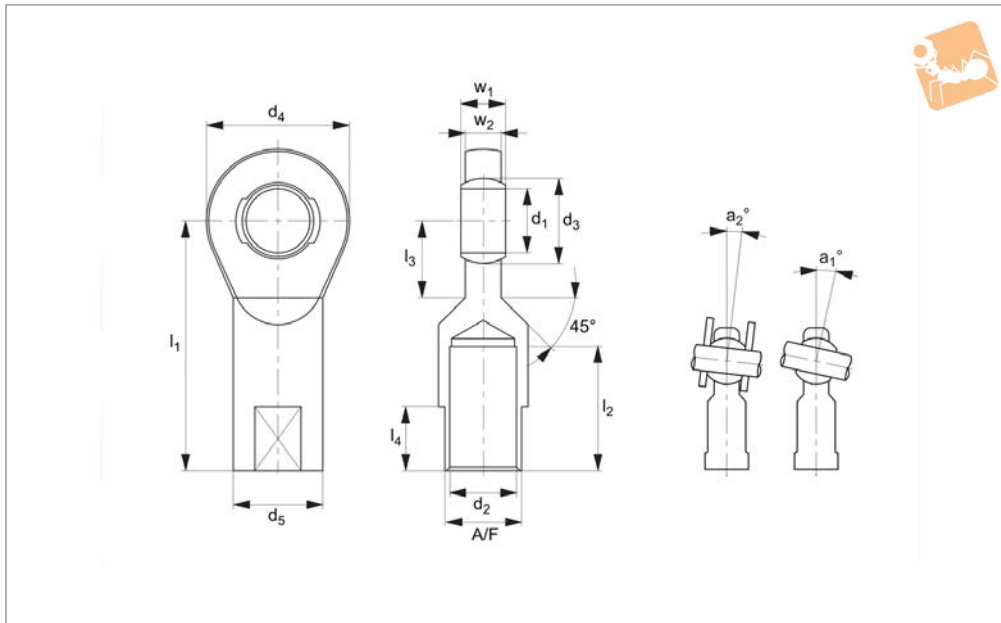

R3554

ROD ENDS

Material

Rod end housing - forged steel, tempered, surface galvanized.

Joint ball - ball bearing steel, hardened and ground, polished and chromium plated.

Race - nylon/teflon/glass compound.

Technical Notes

Female thread maintenance free adapter sizes according to DIN ISO 12240-4, series E.

For tolerances see technical pages.

Tips

Standard thread is right hand thread.

Important Notes

*Denotes fine pitch thread.

Order No.	Thread hand	d ₁	l ₁	d ₂	d ₃	d ₄	d ₅	l ₂	l ₃	Weight g
R3554.R006	Right	6	30	M6	10.0	20	10	12	11	17
R3554.R008	Right	8	36	M8	13.0	23	13	16	12	31
R3554.R010	Right	10	43	M10	16.0	28	16	20	13	54
R3554.R011	Right	10	43	M10x1,25*	16.0	28	16	20	13	54
R3554.R012	Right	12	50	M12	18.0	32	19	22	15	86
R3554.R013	Right	12	50	M12x1,25*	18.0	32	19	22	15	86
R3554.R015	Right	15	61	M14	22.0	38	22	25	18	142
R3554.R017	Right	17	67	M16	25.0	44	25	28	20	208
R3554.R020	Right	20	77	M20x1,5*	29.0	51	28	33	23	290
R3554.R025	Right	25	94	M24x2*	35.5	62	35	42	30	573
R3554.R030	Right	30	110	M30x2*	40.7	70	42	51	32	908
R3554.R035	Right	35	125	M36x3*	47.0	82	50	61	38	1230
R3554.R036	Right	35	130	M36x2*	47.0	82	50	66	38	1230
R3554.R040	Right	40	145	M42x3*	53.0	92	58	71	42	2075
R3554.R041	Right	40	142	M39x3*	53.0	92	52	66	42	1880
R3554.R045	Right	45	165	M45x3*	60.0	102	67	76	50	3085
R3554.R046	Right	45	145	M42x3*	60.0	102	58	66	50	2500
R3554.R050	Right	50	195	M52x3*	66.0	112	70	89	60	3975
R3554.R051	Right	50	160	M45x3*	66.0	112	62	69	60	3200
R3554.R060	Right	60	225	M60x4*	80.0	135	82	103	70	7300
R3554.R061	Right	60	175	M52x3*	80.0	135	71	71	70	5900
R3554.L006	Left	6	30	M6	10.0	20	10	12	11	17
R3554.L008	Left	8	36	M8	13.0	23	13	16	12	31
R3554.L010	Left	10	43	M10	16.0	28	16	20	13	54
R3554.L011	Left	10	43	M10x1,25*	16.0	28	16	20	13	54
R3554.L012	Left	12	50	M12	18.0	32	19	22	15	86
R3554.L013	Left	12	50	M12x1,25*	18.0	32	19	22	15	86
R3554.L015	Left	15	61	M14	22.0	38	22	25	18	142
R3554.L017	Left	17	67	M16	25.0	44	25	28	20	208
R3554.L020	Left	20	77	M20x1,5*	29.0	51	28	33	23	290
R3554.L025	Left	25	94	M24x2*	35.5	62	35	42	30	573
R3554.L030	Left	30	110	M30x2*	40.7	70	42	51	32	908



Order No.	Thread hand	d ₁	l ₁	d ₂	d ₃	d ₄	d ₅	l ₂	l ₃	Weight g
R3554.L035	Left	35	125	M36x3*	47.0	82	50	61	38	1230
R3554.L036	Left	35	130	M36x2*	47.0	82	50	66	38	1230
R3554.L040	Left	40	145	M42x3*	53.0	92	58	71	42	2075
R3554.L041	Left	40	142	M39x3*	53.0	92	52	66	42	1880
R3554.L045	Left	45	165	M45x3*	60.0	102	67	76	50	3085
R3554.L046	Left	45	145	M42x3*	60.0	102	58	66	50	2500
R3554.L050	Left	50	195	M52x3*	66.0	112	70	89	60	3975
R3554.L051	Left	50	160	M45x3*	66.0	112	62	69	60	3200
R3554.L060	Left	60	225	M60x4*	80.0	135	82	103	70	7300
R3554.L061	Left	60	175	M52x3*	80.0	135	71	71	70	5900

Order No.	l ₄	w ₁	w ₂	A/F	a ₁	a ₂	Dyn. load C kN max.	Static load C ₀ kN max.
R3554.R006	-	6	4	9	13.0	6.5	2.5	10.6
R3554.R008	-	8	5	11	15.0	8.0	4.2	13.1
R3554.R010	-	9	6	14	12.0	6.0	6.4	18.8
R3554.R011	-	9	6	14	12.0	6.0	6.4	18.8
R3554.R012	-	10	7	17	10.5	5.0	9.2	28.0
R3554.R013	-	10	7	17	10.5	5.0	9.2	28.0
R3554.R015	-	12	9	19	8.5	4.5	13.4	41.0
R3554.R017	-	14	10	22	10.0	5.5	19.2	57.9
R3554.R020	-	16	12	24	9.0	4.5	25.2	76.7
R3554.R025	-	20	16	30	7.5	3.5	42.4	119.1
R3554.R030	-	22	18	36	6.0	3.0	54.0	141.8
R3554.R035	36	25	20	41	6.5	3.5	70.4	180.8
R3554.R036	41	25	20	41	6.5	3.5	70.4	180.8
R3554.R040	42	28	22	50	7.0	3.5	86.0	222.6
R3554.R041	39	28	22	46	7.0	3.5	86.0	222.6
R3554.R045	45	32	25	55	7.5	4.0	107.0	276.2
R3554.R046	42	32	25	50	7.5	4.0	107.0	276.2
R3554.R050	52	35	28	60	6.5	3.0	132.0	339.2
R3554.R051	45	35	28	55	6.5	3.0	132.0	339.2
R3554.R060	60	44	36	70	6.5	3.5	208.0	532.1
R3554.R061	52	44	36	60	6.5	3.5	208.0	532.1
R3554.L006	-	6	4	9	13.0	6.5	2.5	10.6
R3554.L008	-	8	5	11	15.0	8.0	4.2	13.1
R3554.L010	-	9	6	14	12.0	6.0	6.4	18.8
R3554.L011	-	9	6	14	12.0	6.0	6.4	18.8
R3554.L012	-	10	7	17	10.5	5.0	9.2	28.0
R3554.L013	-	10	7	17	10.5	5.0	9.2	28.0
R3554.L015	-	12	9	19	8.5	4.5	13.4	41.0
R3554.L017	-	14	10	22	10.0	5.5	19.2	57.9
R3554.L020	-	16	12	24	9.0	4.5	25.2	76.7
R3554.L025	-	20	16	30	7.5	3.5	42.4	119.1
R3554.L030	-	22	18	36	6.0	3.0	54.0	141.8
R3554.L035	36	25	20	41	6.5	3.5	70.4	180.8
R3554.L036	41	25	20	41	6.5	3.5	70.4	180.8
R3554.L040	42	28	22	50	7.0	3.5	86.0	222.6
R3554.L041	39	28	22	46	7.0	3.5	86.0	222.6
R3554.L045	45	32	25	55	7.5	4.0	107.0	276.2
R3554.L046	42	32	25	50	7.5	4.0	107.0	276.2
R3554.L050	52	35	28	60	6.5	3.0	132.0	339.2
R3554.L051	45	35	28	55	6.5	3.0	132.0	339.2
R3554.L060	60	44	36	70	6.5	3.5	208.0	532.1
R3554.L061	52	44	36	60	6.5	3.5	208.0	532.1



Heavy-Duty Rod Ends - Female with integral ball bearing

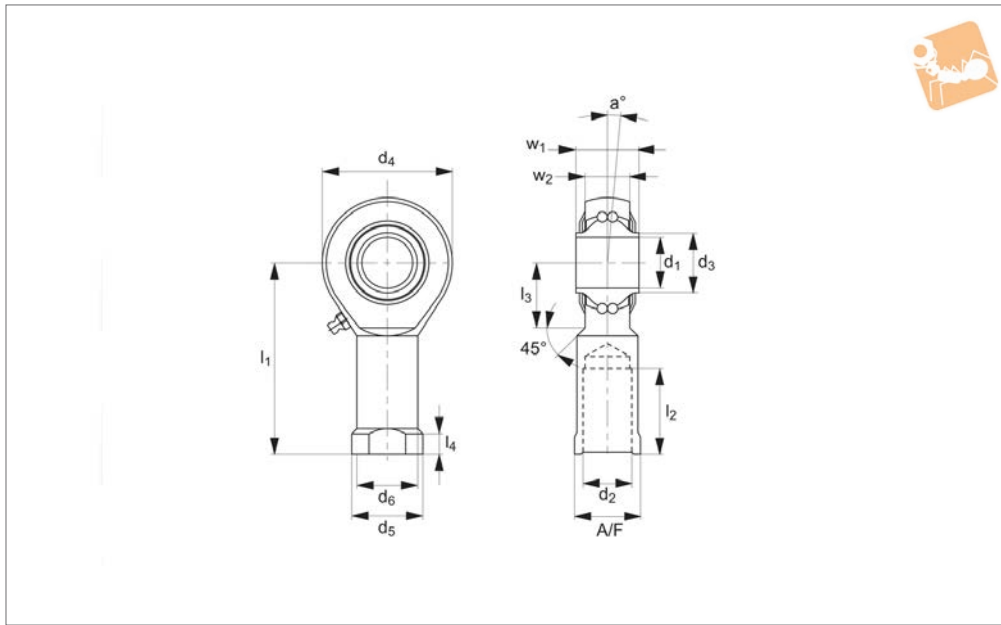

R3557

ROD ENDS

Material

Rod end housing - forged steel, tempered, case hardened bearing race, ground and lapped, surface galvanized.
Inner ring - ball bearing steel, hardened, superfine ground.
Lubrication - calcium-complex-soap-

grease, temp range -20°C to +120°C.
Lubrication nipple - DIN 3405 D1/A (sizes 6 to 10) DIN 71412 H1 (sizes 12 to 30).

Technical Notes

Low maintenance. Sizes according to DIN ISO 12240-4 series K, for tolerances see

technical pages.

Tips

Standard thread is right hand thread.

Important Notes

*Denotes fine pitch thread.

Order No.	Thread hand	d ₁	l ₁	d ₂	d ₃	d ₄	d ₅	d ₆	l ₂	l ₃	l ₄	Weight g
R3557.R006	Right	6	30	M6	9.0	20	10.0	13	12	10	5.0	24
R3557.R008	Right	8	36	M8	10.5	24	12.5	16	16	12	5.0	44
R3557.R010	Right	10	43	M10	12.0	28	15.0	19	20	15	6.5	72
R3557.R012	Right	12	50	M12	14.5	32	17.5	22	22	16	6.5	107
R3557.R014	Right	14	57	M14	17.0	36	20.0	25	25	20	8.0	160
R3557.R016	Right	16	64	M16	19.0	42	22.0	27	28	22	8.0	224
R3557.R018	Right	18	71	M18X1,5*	21.5	46	25.0	31	32	24	10.0	293
R3557.R020	Right	20	77	M20X1,5*	24.5	50	27.5	34	33	26	10.0	367
R3557.R022	Right	22	84	M22X1,5*	26.0	54	30.0	38	37	26	12.0	480
R3557.R025	Right	25	94	M24X2*	29.5	64	30.0	35	42	32	10.0	572
R3557.R030	Right	30	110	M30X2*	34.5	70	40.0	50	51	35	15.0	978
R3557.L006	Left	6	30	M6	9.0	20	10.0	13	12	10	5.0	24
R3557.L008	Left	8	36	M8	10.5	24	12.5	16	16	12	5.0	44
R3557.L010	Left	10	43	M10	12.0	28	15.0	19	20	15	6.5	72
R3557.L012	Left	12	50	M12	14.5	32	17.5	22	22	16	6.5	107
R3557.L016	Left	16	64	M16	19.0	42	22.0	27	28	22	8.0	224
R3557.L014	Left	14	57	M14	17.0	36	20.0	25	25	20	8.0	160
R3557.L018	Left	18	71	M18X1,5*	21.5	46	25.0	31	32	24	10.0	293
R3557.L020	Left	20	77	M20X1,5*	24.5	50	27.5	34	33	26	10.0	367
R3557.L022	Left	22	84	M22X1,5*	26.0	54	30.0	38	37	26	12.0	480
R3557.L025	Left	25	94	M24X2*	29.5	64	30.0	35	42	32	10.0	572
R3557.L030	Left	30	110	M30X2*	34.5	70	40.0	50	51	35	15.0	978

Order No.	w ₁	w ₂	A/F	a°	Calc. factor Y	Dyn. load C kN max.	Calc. factor Y ₀	Speed rpm max.	Static load C ₀ kN max.
R3557.R006	9	6.75	11	8.0	2.09	2.8	2.19	1350	0.7
R3557.R008	12	9.00	14	8.5	1.80	4.0	1.89	1300	1.0
R3557.R010	14	10.50	17	8.0	1.90	4.5	1.81	1225	1.5
R3557.R012	16	12.00	19	7.5	1.74	5.6	1.82	1125	2.0



Order No.	w ₁	w ₂	A/F	a °	Calc. factor Y	Dyn. load C kN max.	Calc. factor Y ₀	Speed rpm max.	Static load C ₀ kN max.
R3557.R014	19	13.50	22	6.0	2.36	7.1	2.48	1025	2.9
R3557.R016	21	15.00	22	8.0	2.24	7.9	2.35	975	3.5
R3557.R018	23	16.50	27	8.5	2.21	11.0	2.31	900	5.7
R3557.R020	25	18.00	30	7.0	2.46	14.2	2.58	825	7.5
R3557.R022	28	20.00	32	8.0	2.35	14.2	2.24	725	7.5
R3557.R025	31	22.00	30	5.0	2.02	14.2	2.12	600	7.5
R3557.R030	37	25.00	41	7.5	2.24	14.2	2.35	450	7.5
R3557.L006	9	6.75	11	8.0	2.09	2.8	2.19	1350	0.7
R3557.L008	12	9.00	14	8.5	1.80	4.0	1.89	1300	1.0
R3557.L010	14	10.50	17	8.0	1.90	4.5	1.81	1225	1.5
R3557.L012	16	12.00	19	7.5	1.74	5.6	1.82	1125	2.0
R3557.L016	21	15.00	22	8.0	2.24	7.9	2.35	1025	3.5
R3557.L014	19	13.50	22	6.0	2.36	7.1	2.48	975	2.9
R3557.L018	23	16.50	27	8.5	2.21	11.0	2.31	900	5.7
R3557.L020	25	18.00	30	7.0	2.46	14.2	2.58	825	7.5
R3557.L022	28	20.00	32	8.0	2.35	14.2	2.24	725	7.5
R3557.L025	31	22.00	30	5.0	2.02	14.2	2.12	600	7.5
R3557.L030	37	25.00	41	7.5	2.24	14.2	2.35	425	7.5



Heavy-Duty Rod Ends - Female with integral ball bearing

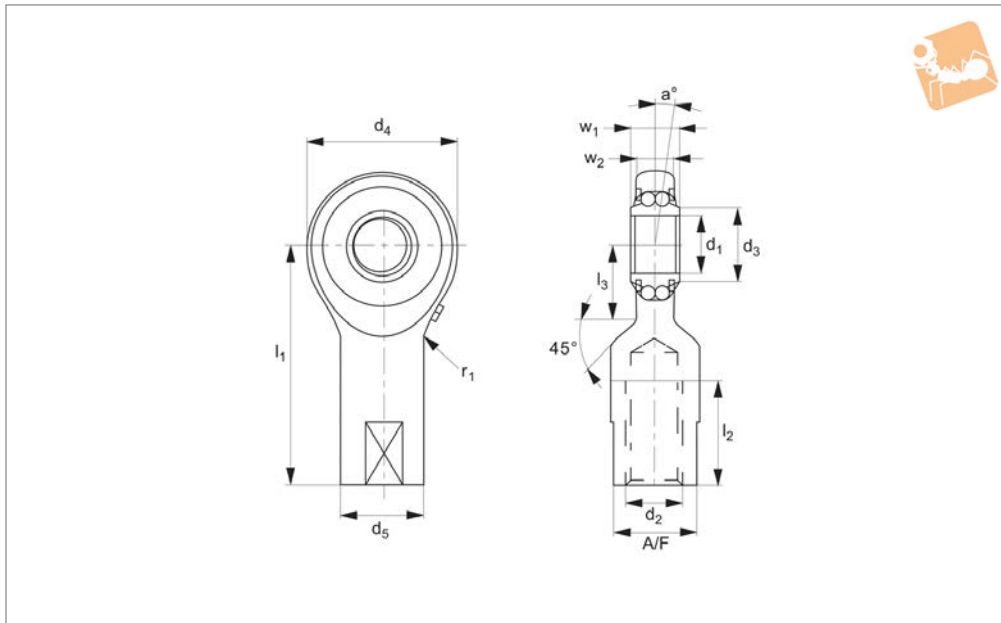

R3560

ROD ENDS

Material

Rod end housing - forged steel, tempered, case hardened bearing race, ground and lapped, surface galvanized.

Inner ring - ball bearing steel, hardened, superfine ground.

Lubrication - calcium-complex-soap-grease, temp range -20°C to +120°C, lubrication nipple - DIN 3405 D1/A.

Technical Notes

Low maintenance, for tolerances see technical pages.

Standard thread is right hand thread.

Tips

Standard thread is right hand thread.

Order No.	Thread hand	d ₁	l ₁	d ₂	d ₃	d ₄	d ₅	l ₂	l ₃	w ₁	w ₂	R	Weight g
R3560.R010	Right	10	38	M8	13.0	30	15	17	14.5	13.0	9	10	63
R3560.R015	Right	15	51	M12	17.5	40	19	24	20.0	16.5	12	15	140
R3560.R020	Right	20	65	M16	24.0	48	22	32	22.0	20.5	15	20	223
R3560.L010	Left	10	38	M8	13.0	30	15	17	14.5	13.0	9	10	63
R3560.L015	Left	15	51	M12	17.5	40	19	24	20.0	16.5	12	15	140
R3560.L020	Left	20	65	M16	24.0	48	22	32	22.0	20.5	15	20	223

Order No.	A/F	a°	Calc. factor Y	Dyn. load C kN max.	Calc. factor Y ₀	Speed rpm max.	Static load C ₀ kN max.
R3560.R010	13	7.0	1.90	2.6	1.81	1225	1.0
R3560.R015	17	7.0	2.30	5.0	2.41	1025	1.9
R3560.R020	19	6.5	2.34	6.1	2.45	850	3.0
R3560.L010	13	7.0	1.90	2.6	1.81	1225	1.0
R3560.L015	17	7.0	2.30	5.0	2.41	1025	1.9
R3560.L020	19	6.5	2.34	6.1	2.45	850	3.0

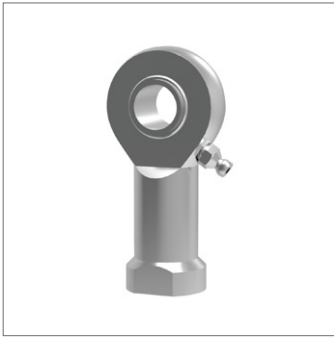

R3562

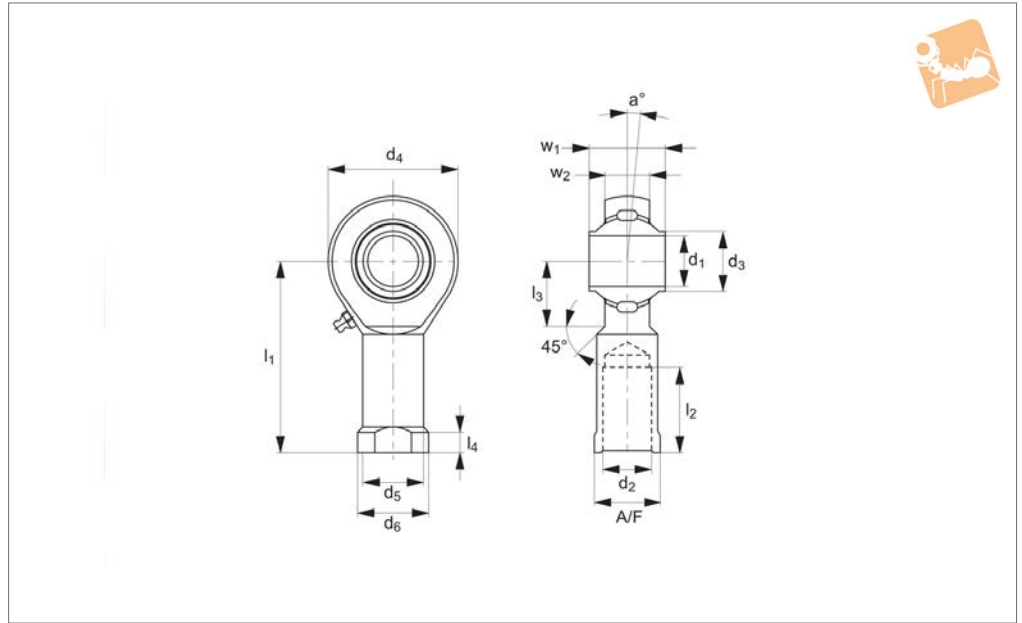

Material

Rod end housing - forged steel, tempered, case hardened bearing race, ground and lapped, surface galvanized.
Inner ring - ball bearing steel, hardened, superfine ground.
Lubrication - calcium-complex-soap-

grease, temp. range -20°C to +120°C, lubrication nipple - DIN 71412 HZ.

Technical Notes

Low maintenance. Sizes according to DIN ISO 12240-4, series K, for tolerances see technical pages.

Tips

Standard thread is right hand thread.

Important Notes

* Denotes fine pitch thread.

Order No.	Thread hand	d ₁	l ₁	d ₂	d ₃	d ₄	d ₅	d ₆	l ₂	Weight g
R3562.R012	Right	12	50.0	M12	14.5	32	17.5	22	22.0	109
R3562.R016	Right	16	64.0	M16	19.0	42	22.0	27	28.0	220
R3562.R020	Right	20	77.0	M20x1,5*	24.5	50	27.5	34	33.0	361
R3562.R025	Right	25	94.0	M24x2*	29.5	64	30.0	35	42.0	565
R3562.R030	Right	30	110.0	M30x2*	34.5	70	40.0	50	51.0	1000
R3562.L012	Left	12	50.0	M12	14.5	32	17.5	22	22.0	109
R3562.L016	Left	16	64.0	M16	19.0	42	22.0	27	28.0	220
R3562.L020	Left	20	77.0	M20x1,5*	24.5	50	27.5	34	33.0	361
R3562.L025	Left	25	94.0	M24x2*	29.5	64	30.0	35	42.0	565
R3562.L030	Left	30	110.0	M30x2*	34.5	70	40.0	50	51.0	1000

Order No.	l ₃	l ₄	w ₁	w ₂	A/F	a°	Dyn. load C kN max.	Speed rpm max.	Static load C ₀ kN max.
R3562.R012	16	6.5	16	12	19	7.5	10.3	1125	6.6
R3562.R016	22	8.0	21	15	22	7.0	13.3	975	8.9
R3562.R020	26	10.0	25	18	30	7.0	17.0	825	11.7
R3562.R025	32	10.0	31	22	30	5.0	24.9	600	18.5
R3562.R030	35	15.0	37	25	41	7.5	32.5	450	24.9
R3562.L012	16	6.5	16	12	19	7.5	10.3	1125	6.6
R3562.L016	22	8.0	21	15	22	7.0	13.3	975	8.9
R3562.L020	26	10.0	25	18	30	7.0	17.0	825	11.7
R3562.L025	32	10.0	31	22	30	5.0	24.9	600	18.5
R3562.L030	35	15.0	37	25	41	7.5	32.5	450	24.9



Stainless Heavy-Duty Rod Ends - with integral self-aligning ball bearing

Rod Ends

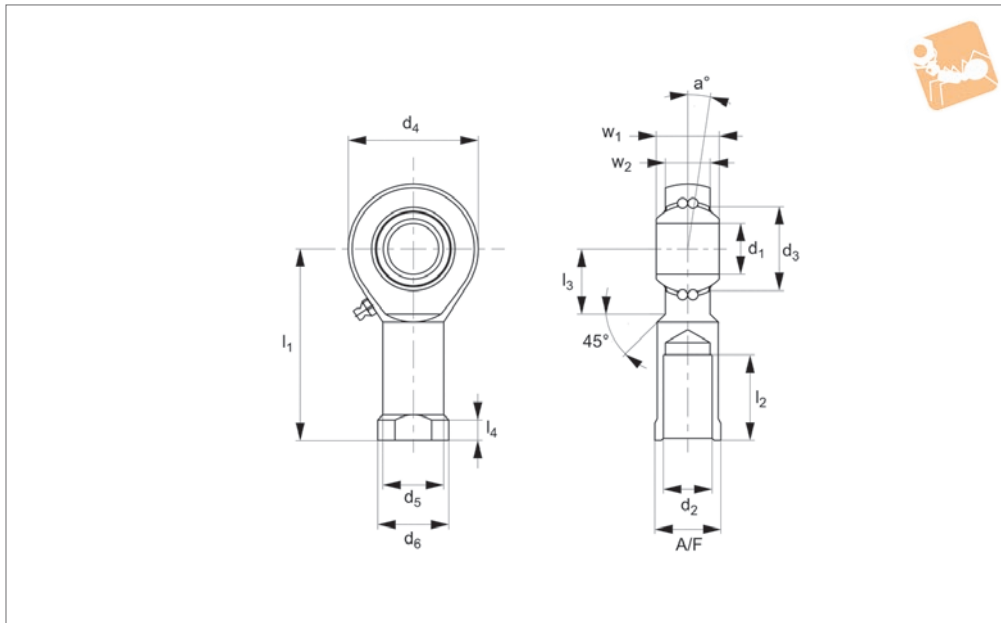

R3564

ROD ENDS

Material

Rod end housing - stainless forged steel (AISI 304), case hardened bearing race
 Inner ring - ball bearing stainless steel (AISI 304), hardened, polished.
 Lubrication - aluminium-complex-soap-grease, temp range -45°C to +120°C.

Lubrication nipple - DIN 3405 D1/A (until size 10) DIN 71412 H1 (from size 12).

Technical Notes

Low maintenance, sizes according to DIN ISO 12240-4 series K, for tolerances see technical pages.

Tips

Standard thread is right hand thread.

Important Notes

*Denotes fine pitch thread.

Order No.	Thread hand	d ₁	l ₁	d ₂	d ₃	d ₄	d ₅	d ₆	l ₂	l ₃	l ₄	Weight g
R3564.R006	Right	6	30	M6	9.0	20	10.0	13	12	10	5.0	24
R3564.R008	Right	8	36	M8	10.5	24	12.5	16	16	12	5.0	44
R3564.R010	Right	10	43	M10	12.0	28	15.0	19	20	15	6.5	72
R3564.R012	Right	12	50	M12	14.5	32	17.5	22	22	16	6.5	107
R3564.R016	Right	16	64	M16	19.0	42	22.0	27	28	22	8.0	224
R3564.R020	Right	20	77	M20X1,5*	24.5	50	27.5	34	33	26	10.0	367
R3564.L006	Left	6	30	M6	9.0	20	10.0	13	12	10	5.0	24
R3564.L008	Left	8	36	M8	10.5	24	12.5	16	16	12	5.0	44
R3564.L010	Left	10	43	M10	12.0	28	15.0	19	20	15	6.5	72
R3564.L012	Left	12	50	M12	14.5	32	17.5	22	22	16	6.5	107
R3564.L016	Left	16	64	M16	19.0	42	22.0	27	28	22	8.0	224
R3564.L020	Left	20	77	M20X1,5*	24.5	50	27.5	34	33	26	10.0	367

Order No.	w ₁	w ₂	A/F	a°	Calc. factor Y	Dyn. load C kN max.	Calc. factor Y ₀	Speed rpm max.	Static load C ₀ kN max.
R3564.R006	9	6.75	11	8.0	2.09	1.9	2.19	1350	0.5
R3564.R008	12	9.00	14	8.5	1.80	2.8	1.89	1300	0.7
R3564.R010	14	10.50	17	8.0	1.90	3.1	1.81	1225	1.0
R3564.R012	16	12.00	19	7.5	1.74	3.5	1.82	1125	1.3
R3564.R016	21	15.00	22	8.0	2.24	4.3	2.35	975	1.6
R3564.R020	25	18.00	30	7.0	2.46	5.4	2.58	825	2.3
R3564.L006	9	6.75	11	8.0	2.09	1.9	2.19	13550	0.5
R3564.L008	12	9.00	14	8.5	1.80	2.8	1.89	1300	0.7
R3564.L010	14	10.50	17	8.0	1.90	3.1	1.81	1225	1.0
R3564.L012	16	12.00	19	7.5	1.74	3.5	1.82	1125	1.3
R3564.L016	21	15.00	22	8.0	2.24	4.3	2.35	975	1.6
R3564.L020	25	18.00	30	7.0	2.46	5.4	2.58	825	2.3

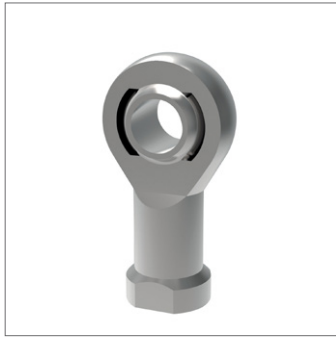

R3566

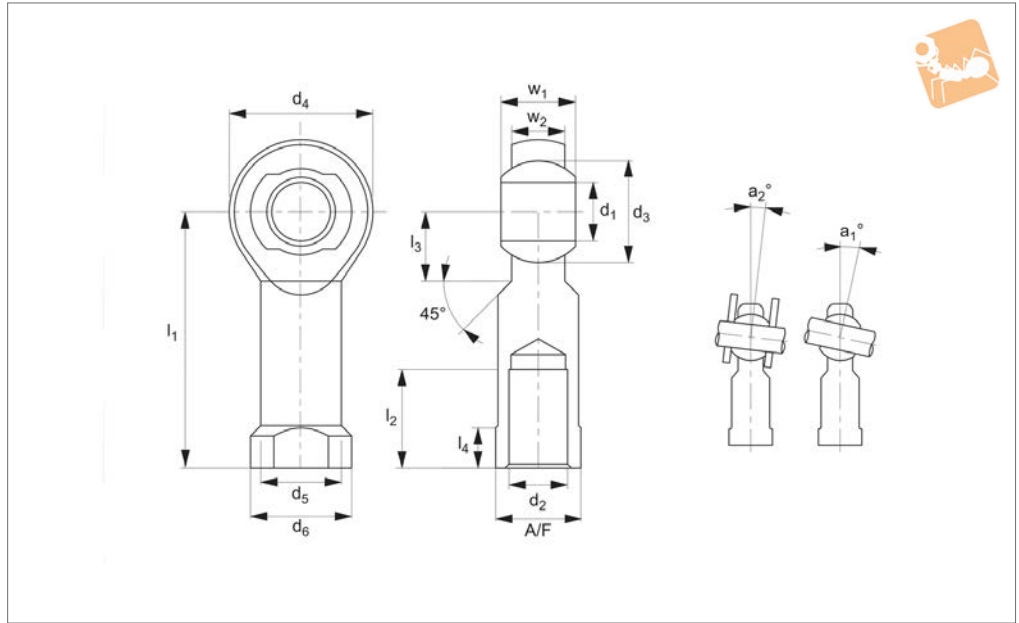

ROD ENDS

Material

Rod end housing: Stainless steel DIN 12240-4 (AISI 304).

Joint Ball: Stainless steel 1.4412, hardened and ground, surface polished.
Race: nylon/teflon/glass compound.

Technical Notes

Maintenance free, for tolerances see technical page 123, standard thread is right hand thread.

Technical page 123, standard thread is right hand thread.

Tips

A2 stainless steel provides good corrosion resistance to a wide range of atmospheric conditions and corrosive media.

It is considered resistant to potable water.

Important Notes

*Denotes fine pitch thread.

Order No.	Thread hand	d ₁	l ₁	d ₂	d ₃	d ₄	d ₅	d ₆	l ₂	Weight g
R3566.R004	Right	5	36	M4	11.11	18	9.0	11	10	18
R3566.R005	Right	5	36	M5	11.11	18	9.0	11	10	18
R3566.R006	Right	6	40	M6	12.70	20	10.0	13	12	24
R3566.R008	Right	8	48	M8	15.87	24	12.5	16	16	45
R3566.R010	Right	10	57	M10	19.05	28	15.0	19	20	74
R3566.R011	Right	10	57	M10x1,25*	19.05	28	15.0	19	20	74
R3566.R012	Right	12	66	M12	22.22	32	17.5	22	22	109
R3566.R013	Right	12	66	M12x1,25*	22.22	32	17.5	22	22	109
R3566.R014	Right	14	75	M14	25.40	36	20.0	25	25	155
R3566.R016	Right	16	85	M16	28.57	42	22.0	27	28	233
R3566.R017	Right	16	85	M16x1,5*	28.57	42	22.0	27	28	233
R3566.R018	Right	18	94	M18x1,5*	31.75	46	25.0	31	32	310
R3566.R020	Right	20	102	M20x1,5*	34.92	50	27.5	34	33	386
R3566.R022	Right	22	111	M22x1,5*	38.10	54	30.0	38	37	520
R3566.R025	Right	25	124	M24x2*	42.85	60	33.5	42	42	705
R3566.R030	Right	30	145	M30x2*	50.80	70	40.0	50	51	1084
R3566.R031	Right	30	145	M27x2*	50.80	70	40.0	50	51	1084
R3566.L004	Left	5	36	M4	11.11	18	9.0	11	10	18
R3566.L005	Left	5	36	M5	11.11	18	9.0	11	10	18
R3566.L006	Left	6	40	M6	12.70	20	10.0	13	12	24
R3566.L008	Left	8	48	M8	15.87	24	12.5	16	16	45
R3566.L010	Left	10	57	M10	19.05	28	15.0	19	20	74
R3566.L011	Left	10	57	M10x1,25*	19.05	28	15.0	19	20	74
R3566.L012	Left	12	66	M12	22.22	32	17.5	22	22	109
R3566.L013	Left	12	66	M12x1,25*	22.22	32	17.5	22	22	109
R3566.L014	Left	14	75	M14	25.40	36	20.0	25	25	155
R3566.L016	Left	16	85	M16	28.57	42	22.0	27	28	233
R3566.L017	Left	16	85	M16x1,5*	28.57	42	22.0	27	28	233
R3566.L018	Left	18	94	M18x1,5*	31.75	46	25.0	31	32	310



Stainless Heavy-Duty Rod Ends - with integral spherical plain bearing

Rod Ends

Order No.	Thread hand	d ₁	l ₁	d ₂	d ₃	d ₄	d ₅	d ₆	l ₂	Weight g
R3566.L020	Left	20	102	M20x1,5*	34.92	50	27.5	34	33	386
R3566.L022	Left	22	111	M22x1,5*	38.10	54	30.0	38	37	520
R3566.L025	Left	25	124	M24x2*	42.85	60	33.5	42	42	705
R3566.L030	Left	30	145	M30x2*	50.80	70	40.0	50	51	1084
R3566.L031	Left	30	145	M27x2*	50.80	70	40.0	50	51	1084

Order No.	l ₃	l ₄	w ₁	w ₂	A/F	a ₁	a ₂	Dyn. load C kN max.	Static load C ₀ kN max.
R3566.R004	10	4.0	8	6.00	9	13.0	7.5	3.9	7.9
R3566.R005	10	4.0	8	6.00	9	13.0	7.5	3.9	7.9
R3566.R006	12	5.0	9	6.75	11	13.0	6.5	4.6	9.4
R3566.R008	12	5.0	12	9.00	14	14.5	7.5	7.0	14.1
R3566.R010	15	6.5	14	10.50	17	13.5	8.0	10.4	20.1
R3566.R011	15	6.5	14	10.50	17	13.5	8.0	10.4	20.1
R3566.R012	16	6.5	16	12.00	19	13.0	8.0	12.4	24.5
R3566.R013	16	6.5	16	12.00	19	13.0	8.0	12.4	24.5
R3566.R014	20	8.0	19	13.50	22	16.0	9.5	15.4	30.4
R3566.R016	22	8.0	21	15.00	22	15.5	8.5	22.4	43.7
R3566.R017	22	8.0	21	15.00	22	15.5	8.5	22.4	43.7
R3566.R018	24	10.0	23	16.50	27	15.0	9.5	26.3	51.2
R3566.R020	26	10.0	25	18.00	30	14.5	9.0	30.8	60.3
R3566.R022	26	12.0	28	20.00	32	15.5	10.0	38.2	70.0
R3566.R025	30	12.0	31	22.00	36	15.0	10.0	45.4	87.0
R3566.R030	35	15.0	37	25.00	41	17.0	10.5	55.0	106.8
R3566.R031	35	15.0	37	25.00	41	17.0	10.5	55.0	106.8
R3566.L004	10	4.0	8	6.00	9	13.0	7.5	3.9	7.9
R3566.L005	10	4.0	8	6.00	9	13.0	7.5	3.9	7.9
R3566.L006	12	5.0	9	6.75	11	13.0	6.5	4.6	9.4
R3566.L008	12	5.0	12	9.00	14	14.5	7.5	7.0	14.1
R3566.L010	15	6.5	14	10.50	17	13.5	8.0	10.4	20.1
R3566.L011	15	6.5	14	10.50	17	13.5	8.0	10.4	20.1
R3566.L012	16	6.5	16	12.00	19	13.0	8.0	12.4	24.5
R3566.L013	16	6.5	16	12.00	19	13.0	8.0	12.4	24.5
R3566.L014	20	8.0	19	13.50	22	16.0	9.5	15.4	30.4
R3566.L016	22	8.0	21	15.00	22	15.5	8.5	22.4	43.7
R3566.L017	22	8.0	21	15.00	22	15.5	8.5	22.4	43.7
R3566.L018	24	10.0	23	16.50	27	15.0	9.5	26.3	51.2
R3566.L020	26	10.0	25	18.00	30	14.5	9.0	30.8	60.3
R3566.L022	26	12.0	28	20.00	32	15.5	10.0	38.2	70.0
R3566.L025	30	12.0	31	22.00	36	15.0	10.0	45.4	87.0
R3566.L030	35	15.0	37	25.00	41	17.0	10.5	55.0	106.8
R3566.L031	35	15.0	37	25.00	41	17.0	10.5	55.0	106.8

ROD ENDS



R3568

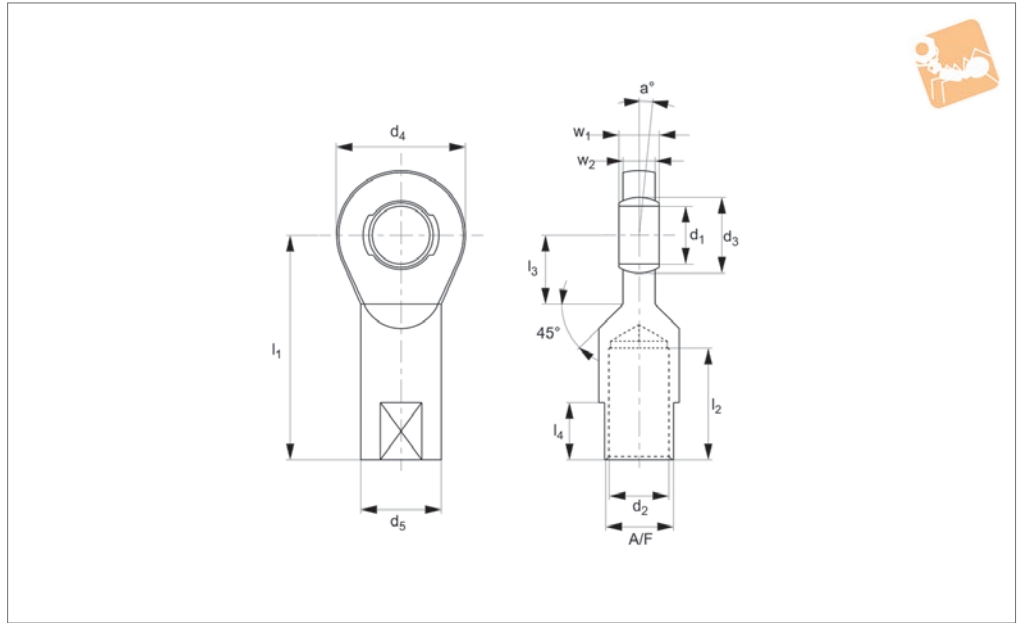

Material

Rod end housing - forged stainless steel
DIN 1.4301 (AISI 304).
Joint ball - stainless steel (AISI 304),
hardened, polished and ground
Race - polyamid-PTFE-fibreglass-

compound.

Technical Notes

Maintenance free, sizes according to DIN
ISO 12240-4, series E, for tolerances technical pages.

Tips

Standard thread is right hand thread.

Important Notes

* Denotes fine pitch thread

Order No.	Thread hand	d ₁	l ₁	d ₂	d ₃	d ₄	d ₅	l ₂	Weight g
R3568.R006	Right	6	30	M6	10.0	20	10	12	17
R3568.R008	Right	8	36	M8	13.0	23	13	16	31
R3568.R010	Right	10	43	M10	16.0	28	16	20	54
R3568.R011	Right	10	43	M10x1,25*	16.0	28	16	20	54
R3568.R012	Right	12	50	M12	18.0	32	19	22	86
R3568.R013	Right	12	50	M12x1,25*	18.0	32	19	22	86
R3568.R015	Right	15	61	M14	22.0	38	22	25	142
R3568.R017	Right	17	67	M16	25.0	44	25	28	208
R3568.R020	Right	20	77	M20x1,5*	29.0	51	28	33	290
R3568.R025	Right	25	94	M24x2*	35.5	62	35	42	573
R3568.R030	Right	30	110	M30x2*	40.7	70	42	51	908
R3568.R035	Right	35	125	M36x3*	47.0	82	50	61	1230
R3568.R036	Right	35	130	M36x2*	47.0	82	50	66	1230
R3568.R040	Right	40	145	M42x3*	53.0	92	58	71	2075
R3568.R041	Right	40	142	M39x3*	53.0	92	52	66	1880
R3568.R045	Right	45	165	M45x3*	60.0	102	67	76	3085
R3568.R046	Right	45	145	M42x3*	60.0	102	58	66	2500
R3568.R050	Right	50	195	M52x3*	66.0	112	70	89	3975
R3568.R051	Right	50	160	M45x3*	66.0	112	62	69	3200
R3568.R060	Right	60	225	M60x4*	80.0	135	82	103	7300
R3568.R061	Right	60	175	M52x3*	80.0	135	71	71	5900
R3568.L006	Left	6	30	M6	10.0	20	10	12	17
R3568.L008	Left	8	36	M8	13.0	23	13	16	31
R3568.L010	Left	10	43	M10	16.0	28	16	20	54
R3568.L011	Left	10	43	M10x1,25*	16.0	28	16	20	54
R3568.L012	Left	12	50	M12	18.0	32	19	22	86
R3568.L013	Left	12	50	M12x1,25*	18.0	32	19	22	86
R3568.L015	Left	15	61	M14	22.0	38	22	25	142
R3568.L017	Left	17	67	M16	25.0	44	25	28	208
R3568.L020	Left	20	77	M20x1,5*	29.0	51	28	33	290
R3568.L025	Left	25	94	M24x2*	35.5	62	35	42	573
R3568.L030	Left	30	110	M30x2*	40.7	70	42	51	908



Stainless Heavy-Duty Rod Ends - with integral spherical plain bearing

Rod Ends

Order No.	Thread hand	d ₁	l ₁	d ₂	d ₃	d ₄	d ₅	l ₂	Weight g
R3568.L035	Left	35	125	M36x3*	47.0	82	50	61	1230
R3568.L036	Left	35	130	M36x2*	47.0	82	50	66	1230
R3568.L040	Left	40	145	M42x3*	53.0	92	58	71	2075
R3568.L041	Left	40	142	M39x3*	53.0	92	52	66	1880
R3568.L045	Left	45	165	M45x3*	60.0	102	67	76	3085
R3568.L046	Left	45	145	M42x3*	60.0	102	58	66	2500
R3568.L050	Left	50	195	M52x3*	66.0	112	70	89	3975
R3568.L051	Left	50	160	M45x3*	66.0	112	62	69	3200
R3568.L060	Left	60	225	M60x4*	80.0	135	82	103	7300
R3568.L061	Left	60	175	M52x3*	80.0	135	71	71	5900

Order No.	l ₃	l ₄	w ₁	w ₂	A/F	α °	Dyn. load C kN max.	Static load C ₀ kN max.
R3568.R006	11	-	6	4	9	13.0	2.5	4.8
R3568.R008	12	-	8	5	11	15.0	4.2	5.9
R3568.R010	13	-	9	6	14	12.0	6.4	8.5
R3568.R011	13	-	9	6	14	12.0	6.4	8.5
R3568.R012	15	-	10	7	17	10.5	9.2	12.6
R3568.R013	15	-	10	7	17	10.5	9.2	12.6
R3568.R015	18	-	12	9	19	8.5	13.4	18.5
R3568.R017	20	-	14	10	22	10.0	19.2	26.0
R3568.R020	23	-	16	12	24	9.0	25.2	34.5
R3568.R025	30	-	20	16	30	7.5	42.4	54.0
R3568.R030	32	-	22	18	36	6.0	54.0	63.8
R3568.R035	38	36	25	20	41	6.5	70.4	81.4
R3568.R036	38	41	25	20	41	6.5	70.4	81.4
R3568.R040	42	42	28	22	50	7.0	86.0	100.2
R3568.R041	42	39	28	22	46	7.0	86.0	100.2
R3568.R045	50	45	32	25	55	7.5	86.0	124.3
R3568.R046	50	42	32	25	50	7.5	107.0	124.3
R3568.R050	60	52	35	28	60	6.5	132.0	152.6
R3568.R051	60	45	35	28	55	6.5	132.0	152.6
R3568.R060	70	60	44	36	70	6.5	208.0	239.5
R3568.R061	70	52	44	36	60	6.5	208.0	239.5
R3568.L006	11	-	6	4	9	13.0	2.5	4.8
R3568.L008	12	-	8	5	11	15.0	4.2	5.9
R3568.L010	13	-	9	6	14	12.0	6.4	8.5
R3568.L011	13	-	9	6	14	12.0	6.4	8.5
R3568.L012	15	-	10	7	17	10.5	9.2	12.6
R3568.L013	15	-	10	7	17	10.5	9.2	12.6
R3568.L015	18	-	12	9	19	8.5	13.4	18.5
R3568.L017	20	-	14	10	22	10.0	19.2	26.0
R3568.L020	23	-	16	12	24	9.0	25.2	34.5
R3568.L025	30	-	20	16	30	7.5	42.4	54.0
R3568.L030	32	-	22	18	36	6.0	54.0	63.8
R3568.L035	38	36	25	20	41	6.5	70.4	81.4
R3568.L036	38	41	25	20	41	6.5	70.4	81.4
R3568.L040	42	42	28	22	50	7.0	86.0	100.2
R3568.L041	42	39	28	22	46	7.0	86.0	100.2
R3568.L045	50	45	32	25	55	7.5	107.0	124.3
R3568.L046	50	42	32	25	50	7.5	107.0	124.3
R3568.L050	60	52	35	28	60	6.5	132.0	152.6
R3568.L051	60	45	35	28	55	6.5	132.0	152.6
R3568.L060	70	60	44	36	70	6.5	208.0	239.5
R3568.L061	70	52	44	36	60	6.5	208.0	239.5

ROD ENDS

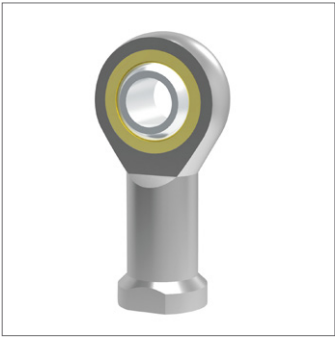

R3570

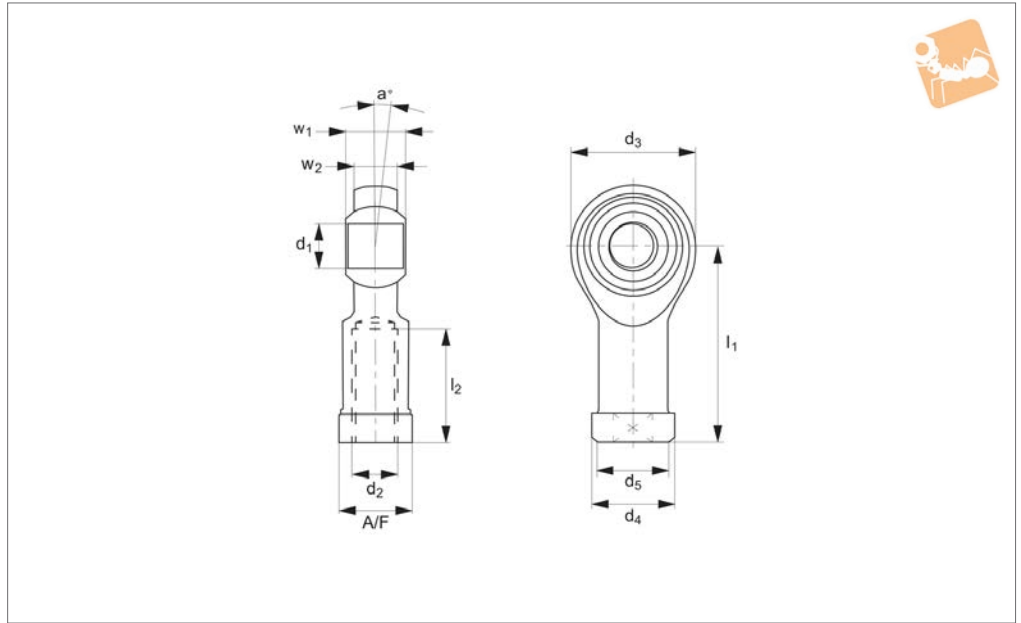

Material

Ball: low carbon steel, surface hardened.
Silver zinc plated.
Housing: low carbon steel, zinc plated for corrosion resistance.

Bearing race: teflon.

Brass bearing with PTFE composite lining.

Technical Notes

Standard thread is right hand thread.

Important Notes

Housing styles are subject to change.

Order No.	Thread hand	d ₁ tol. H7	l ₁	d ₂	d ₃	d ₄	d ₅	l ₂	w ₁	w ₂	A/F	a _o	Static load C ₀ kN max.
R3570.R005	Right	5	27	M5	18	11	9	10	8	6	9	13	4.8
R3570.R006	Right	6	30	M6	20	13	10	12	9	6.75	11	13	6.2
R3570.R008	Right	8	36	M8	24	16	12.5	16	12	9	13	14	10.3
R3570.R010	Right	10	43	M10	28	19	15	20	14	10.5	17	13	14.4
R3570.R012	Right	12	50	M12	34	22	17.5	22	16	12	19	13	19.2
R3570.R016	Right	16	64	M16	42	27	22	28	21	15	22	15	31.2
R3570.L005	Left	5	27	M5	18	11	9	10	8	6	9	13	4.8
R3570.L006	Left	6	30	M6	20	13	10	12	9	6.75	11	13	6.2
R3570.L008	Left	8	36	M8	24	16	12.5	16	12	9	13	14	10.3
R3570.L010	Left	10	43	M10	28	19	15	20	14	10.5	17	13	14.4
R3570.L012	Left	12	50	M12	34	22	17.5	22	16	12	19	13	19.2
R3570.L016	Left	16	64	M16	42	27	22	28	21	15	22	15	31.2



Low Cost Rod End - Female

with teflon bearing race

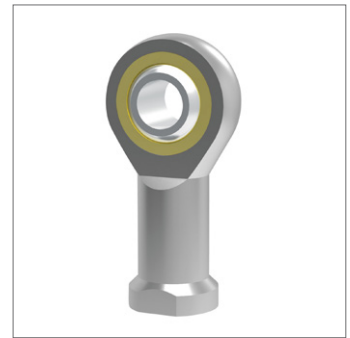

R3572.F

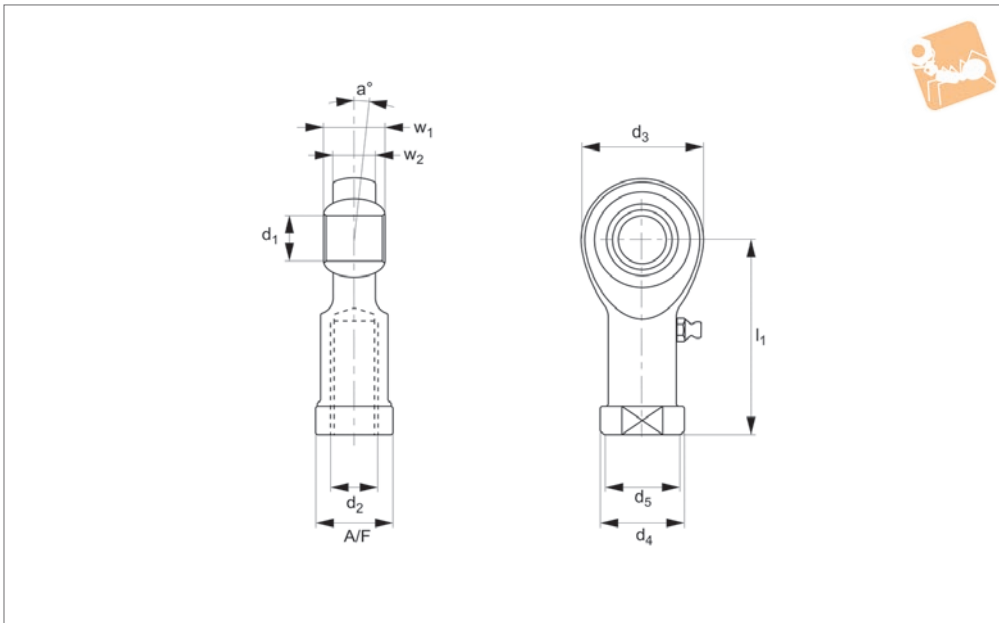

Material

Ball: low carbon steel, surface hardened.
 Silver zinc plated.
 Housing: low carbon steel, zinc plated for

corrosion resistance.

Technical Notes

Standard thread is right hand thread.

Order No.	Thread hand	d ₁ tol. H7	l ₁	d ₂	d ₃	d ₄	d ₅	l ₂	l ₃	w ₁	w ₂	A/F	a°	Static load C ₀ kN max.
R3572.FL005	Left	5	27	M 5	16	11	8.5	10	35	8	6.0	9	13	4.6
R3572.FL006	Left	6	30	M 6	18	13	10.0	12	39	9	6.75	11	13	5.8
R3572.FL008	Left	8	36	M 8	22	16	12.5	16	47	12	9.0	14	14	9.3
R3572.FL010	Left	10	43	M10	26	19	15.0	20	56	14	10.5	17	13	11.6
R3572.FL012	Left	12	50	M12	30	22	17.5	22	65	16	12.0	19	13	13.6
R3572.FL013	Left	12	50	M12x1,25	30	22	17.5	22	65	16	12.0	19	13	13.6
R3572.FL014	Left	14	57	M14	34	25	20.0	25	74	19	13.5	22	16	19.2
R3572.FL016	Left	16	64	M16	40	27	22.0	28	84	21	15.0	24	15	22.8
R3572.FL017	Left	16	64	M16x1,5	40	27	22.0	28	84	21	15.0	24	15	22.8
R3572.FL018	Left	18	71	M18x1,5	44	31	25.0	32	93	23	16.5	27	15	34.0
R3572.FL020	Left	20	77	M20x1,5	50	34	27.5	33	102	25	18.0	30	14	42.0
R3572.FL022	Left	22	84	M22x1,5	54	38	30.0	37	111	28	20.0	32	15	45.6
R3572.FL025	Left	25	94	M24x2	60	42	33.5	42	124	31	22.0	36	15	54.4
R3572.FL030	Left	30	110	M30x2	70	50	40.0	51	145	37	25.0	41	17	70.4

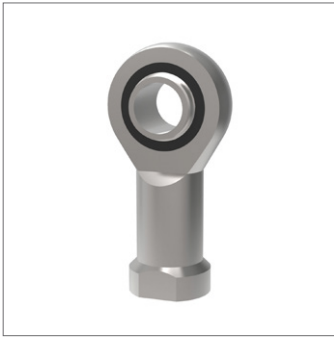

R3574

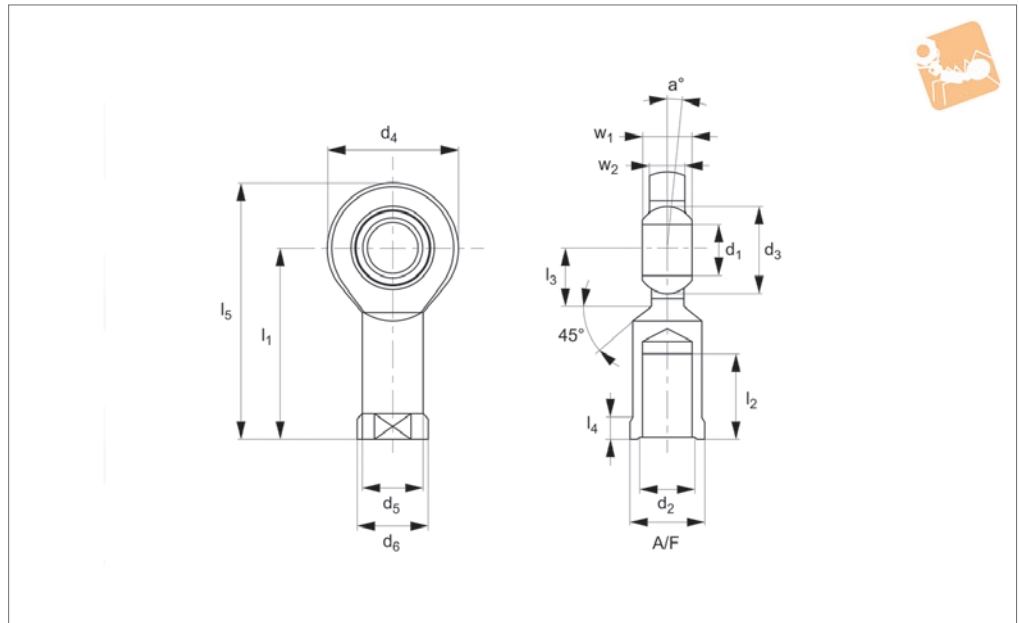

Material

Housing: Heat treated steel, surface galvanized, free of Cr VI. Outer ring: heat treated steel, hardened, single split, bonded with PTFE fabric.

Joint Ball: Ball bearing steel, hardened, ground, polished up to size 12, hard chromium plated.

Technical Notes

Standard thread is right hand thread,

series E, maintenance free.

Tips

For tolerances see technical page 123

Important Notes

*Denotes fine pitch thread.

Order No.	Thread hand	d ₁ tol. K6	l ₁	d ₂	d ₃	d ₄	d ₅	d ₆	Weight g
R3574.R006	Right	6	30	M6	10	21	10.0	13	21
R3574.R008	Right	8	36	M8	13	24	12.5	16	39
R3574.R010	Right	10	43	M10	16	29	15	19	61
R3574.R012	Right	12	50	M12	18	34	17.5	22	96
R3574.R015	Right	15	61	M14	22	40	21	26	180
R3574.R017	Right	17	67	M16	25	46	24	30	220
R3574.R020	Right	20	77	M20x1,5*	29	53	27.5	35	350
R3574.R025	Right	25	94	M24x2*	35.5	64	33.5	42	640
R3574.R030	Right	30	110	M30x2*	40.7	73	40	50	930
R3574.R035	Right	35	125	M36x3*	47	82	47	58	1300
R3574.R040	Right	40	142	M39x3*	53	92	52	65	2000
R3574.R041	Right	40	142	M42x3*	53	92	52	65	1960
R3574.R045	Right	45	145	M42x3*	60	102	58	70	2500
R3574.R046	Right	45	145	M45x3*	60	102	58	70	2440
R3574.R050	Right	50	160	M45x3*	66	112	62	75	3500
R3574.R051	Right	50	160	M52x3*	66	112	62	75	3400
R3574.R060	Right	60	175	M52x3*	80	135	70	88	5500
R3574.R061	Right	60	175	M60x4*	80	135	70	88	5380
R3574.R070	Right	70	200	M56x4*	92	160	80	98	8600
R3574.R071	Right	70	200	M72x4*	92	160	80	98	8420
R3574.R080	Right	80	230	M64x4*	105	180	95	110	12000
R3574.R081	Right	80	230	M80x4*	110	180	95	110	11800
R3574.L006	Left	6	30	M6	10	21	10.0	13	21
R3574.L008	Left	8	36	M8	13	24	12.5	16	39
R3574.L010	Left	10	43	M10	16	29	15	19	61
R3574.L012	Left	12	50	M12	18	34	17.5	22	96
R3574.L015	Left	15	61	M14	22	40	21	26	180
R3574.L017	Left	17	67	M16	25	46	24	30	220
R3574.L020	Left	20	77	M20x1,5*	29	53	27.5	35	350
R3574.L025	Left	25	94	M24x2*	35.5	64	33.5	42	640
R3574.L030	Left	30	110	M30x2*	40.7	73	40	50	930
R3574.L035	Left	35	125	M36x3*	47	82	47	58	1300



Low Cost Rod End - Female

with integral spherical plain bearings

Rod Ends

Order No.	Thread hand	d ₁ tol. K6	l ₁	d ₂	d ₃	d ₄	d ₅	d ₆	Weight g
R3574.L040	Left	40	142	M39x3*	53	92	52	65	2000
R3574.L041	Left	40	142	M42x3*	53	92	52	65	1960
R3574.L045	Left	45	145	M42x3*	60	102	58	70	2500
R3574.L046	Left	45	145	M45x3*	60	102	58	70	2440
R3574.L050	Left	50	160	M45x3*	66	112	62	75	3500
R3574.L051	Left	50	160	M52x3*	66	112	62	75	3400
R3574.L060	Left	60	175	M52x3*	80	135	70	88	5500
R3574.L061	Left	60	175	M60x4*	80	135	70	88	5380
R3574.L070	Left	70	200	M56x4*	92	160	80	98	8600
R3574.L071	Left	70	200	M72x4*	92	160	80	98	8420
R3574.L080	Left	80	230	M64x4*	105	180	95	110	12000
R3574.L081	Left	80	230	M80x4*	110	180	95	110	11800

Order No.	l ₂	l ₃	l ₄	l ₅	w ₁	w ₂	A/F	α°	Static load C ₀ kN max.
R3574.R006	11	12	5	40.5	6	4.4	11	13	6.6
R3574.R008	15	14	5	48	8	6	14	15	10.3
R3574.R010	20	15	6.5	57.5	9	7	17	12	14.1
R3574.R012	23	18	6.5	67	10	8	19	11	19.6
R3574.R015	30	20	8	81	12	10	22	8	28.8
R3574.R017	34	23	10	90	14	11	27	10	36.0
R3574.R020	40	27	10	103.5	16	13	32	9	48.0
R3574.R025	48	32	12	126	20	17	36	7	66.4
R3574.R030	56	37	15	146.5	22	19	41	6	88.0
R3574.R035	60	42	15	166	25	21	50	6	117
R3574.R040	65	48	18	188	28	23	55	7	144
R3574.R041	65	48	18	188	28	23	55	7	144
R3574.R045	65	52	20	196	32	27	60	7	192
R3574.R046	65	52	50	196	32	27	60	7	192
R3574.R050	68	60	20	216	35	30	65	6	232
R3574.R051	68	60	20	216	35	30	65	6	232
R3574.R060	70	75	20	242.5	44	38	75	6	360
R3574.R061	70	75	20	242.5	44	38	75	6	360
R3574.R070	80	87	20	280	49	42	85	6	488
R3574.R071	80	87	20	280	49	42	85	6	488
R3574.R080	85	100	24	320	55	47	100	6	600
R3574.R081	85	100	25	320	55	47	100	6	600
R3574.L006	11	12	5	40.5	6	4.4	11	13	6.6
R3574.L008	15	14	5	48	8	6	14	15	10.3
R3574.L010	20	15	6.5	57.5	9	7	17	12	14.1
R3574.L012	23	18	6.5	67	10	8	19	11	19.6
R3574.L015	30	20	8	81	12	10	22	8	28.8
R3574.L017	34	23	10	90	14	11	27	10	36.0
R3574.L020	40	27	10	103.5	16	13	32	9	48.0
R3574.L025	48	32	12	126	20	17	36	7	66.4
R3574.L030	56	37	15	146.5	22	19	41	6	88.0
R3574.L035	60	42	15	166	25	21	50	6	117
R3574.L040	65	48	18	188	28	23	55	7	144
R3574.L041	65	48	18	188	28	23	55	7	144
R3574.L045	65	52	20	196	32	27	60	7	192
R3574.L046	65	52	50	196	32	27	60	7	192
R3574.L050	68	60	20	216	35	30	65	6	232
R3574.L051	68	60	20	216	35	30	65	6	232
R3574.L060	70	75	20	242.5	44	38	75	6	360
R3574.L061	70	75	20	242.5	44	38	75	6	360
R3574.L070	80	87	20	280	49	42	85	6	488
R3574.L071	80	87	20	280	49	42	85	6	488
R3574.L080	85	100	24	320	55	47	100	6	600
R3574.L081	85	100	25	320	55	47	100	6	600

ROD ENDS



R3575.F

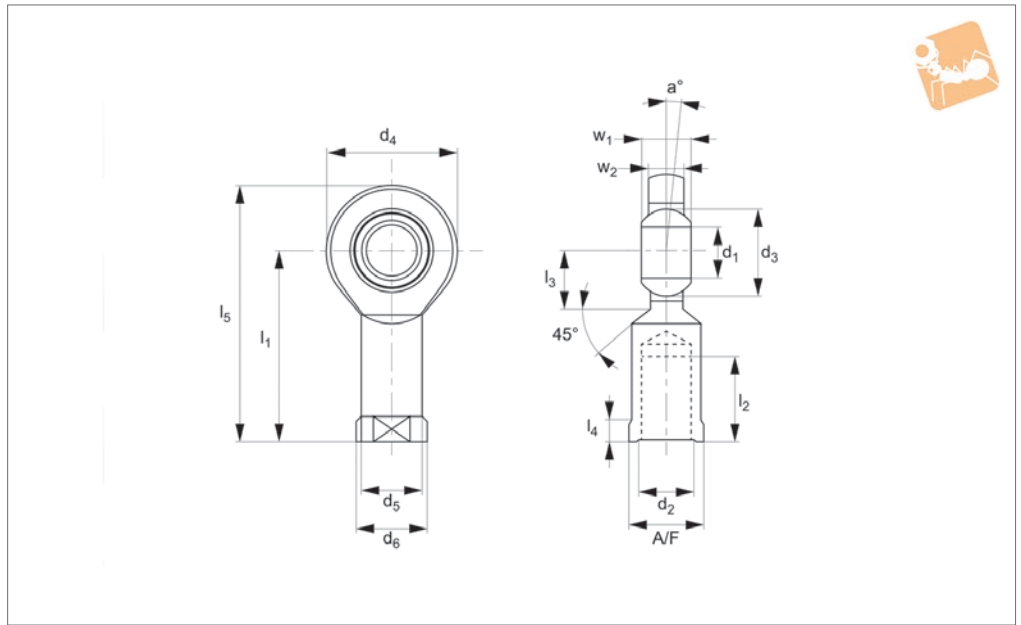

Material

Housing: Heat treated steel, surface galvanized, free of Cr VI. Outer ring: heat treated steel, hardened, single split, bonded with PTFE fabric.

Joint Ball: Ball bearing steel, hardened, ground, polished up to size 12, hard chromium plated.

Technical Notes

For tolerances see technical pages, main-

tenance required.

Tips

Standard thread is right hand thread.

Important Notes

*Denotes fine pitch thread.

Order No.	Thread hand	Type	d ₁ tol. H7	l ₁	d ₂	d ₃	d ₄	l ₂	l ₃	w ₁	w ₂	a°	Static load C ₀ kN max.	Weight g
R3575.FL006	Left	Female	6	36	M 6	10	21	18	12	6	4.4	13	6.6	17
R3575.FL008	Left	Female	8	42	M 8	13	24	22	14	8	6	15	10.3	29
R3575.FL010	Left	Female	10	48	M10	16	29	26	15	9	7	12	14.1	51
R3575.FL012	Left	Female	12	54	M12	18	34	28	18	10	8	11	19.6	86
R3575.FL015	Left	Female	15	63	M14	22	40	34	20	12	10	8	28.8	140
R3575.FL017	Left	Female	17	69	M16	25	46	36	23	14	11	10	36.0	190
R3575.FL020	Left	Female	20	78	M20x1.5*	29	53	43	27	16	13	9	48.0	310
R3575.FL025	Left	Female	25	94	M24x2*	35.5	64	53	32	20	17	7	66.4	560
R3575.FL030	Left	Female	30	110	M30x2*	40.7	73	65	37	22	19	6	88.0	890
R3575.FL035	Left	Female	35	140	M36x3*	47	82	82	42	25	21	6	116.8	1400
R3575.FL040	Left	Female	40	150	M39x3*	53	92	86	48	28	23	7	144	1800
R3575.FL041	Left	Female	40	150	M42x3*	53	92	86	48	28	23	7	144	1850
R3575.FL045	Left	Female	45	163	M43x3*	60	102	94	52	32	27	7	192	2600
R3575.FL046	Left	Female	45	163	M45x3*	60	102	94	52	32	27	7	192	2660
R3575.FL050	Left	Female	50	185	M45x3*	66	112	107	60	35	30	6	232	3400
R3575.FL051	Left	Female	50	185	M52x3*	66	112	107	60	35	30	6	232	3500
R3575.FL060	Left	Female	60	210	M52x3*	80	135	115	75	44	38	6	360	5900
R3575.FL061	Left	Female	60	210	M60x4*	80	135	115	75	44	38	6	360	6020
R3575.FL070	Left	Female	70	235	M56x4*	92	160	125	87	49	42	6	488	8200
R3575.FL071	Left	Female	70	235	M72x4*	92	160	125	87	49	42	6	488	8380
R3575.FL080	Left	Female	80	270	M64x4*	105	180	140	100	55	47	6	600	12000
R3575.FL081	Left	Female	80	270	M80x4*	105	180	140	100	55	47	6	600	12200



Stainless Low Cost Rod Ends

Female

Rod Ends

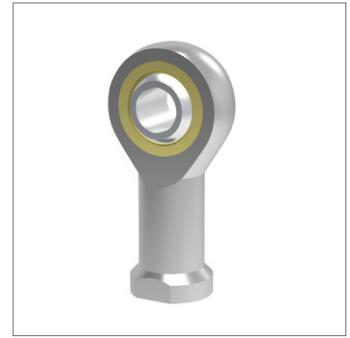

R3576.A2

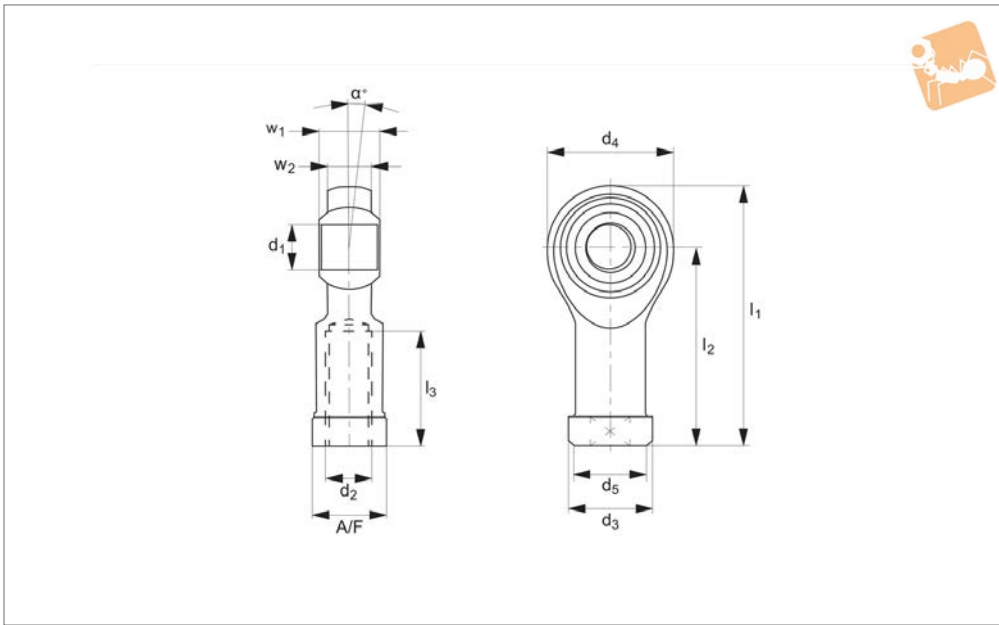

Material

Housing: stainless steel (AISI 303)
Ball: Stainless steel, hardened ground and

polished stainless steel bearing rings

series K, maintenance free.

Technical Notes

Standard thread is right hand thread,

Order No.	Thread hand	d ₁ tol. H7	l ₁	d ₂	d ₃	d ₄	d ₅	l ₂	l ₃	w ₁	w ₂	A/F	α °	Static load C ₀ kN max.	Weight g
R3576.R005-A2	Right	5	36	M 5	18	11	8.5	27	10	8	6.00	9	13	4.8	16
R3576.R006-A2	Right	6	40	M 6	20	13	10	30	12	9	6.75	11	13	6.2	22
R3576.R008-A2	Right	8	48	M 8	16	24	12.5	36	16	12	9.00	14	14	10.3	47
R3576.R010-A2	Right	10	57	M10	28	19	15	43	20	14	10.50	17	13	14.4	77
R3576.R012-A2	Right	12	66	M12	32	22	17.5	50	22	16	12.00	19	13	19.2	100
R3576.R016-A2	Right	16	85	M16	42	27	22	64	28	21	15.00	22	15	31.2	220
R3576.L005-A2	Left	5	36	M 5	18	11	8.5	27	10	8	6.00	9	13	4.8	16
R3576.L006-A2	Left	6	40	M 6	20	13	10	30	12	9	6.75	11	13	6.2	22
R3576.L008-A2	Left	8	48	M 8	16	24	12.5	36	16	12	9.00	14	14	10.3	47
R3576.L010-A2	Left	10	57	M10	28	19	15	43	20	14	10.50	17	13	14.4	77
R3576.L012-A2	Left	12	66	M12	32	22	17.5	50	22	16	12.00	19	13	19.2	100
R3576.L016-A2	Left	16	85	M16	42	27	22	64	28	21	15.00	22	15	31.2	220



ROD ENDS

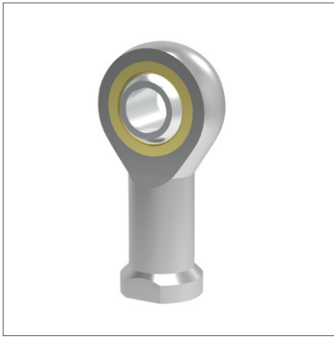

R3576.A4

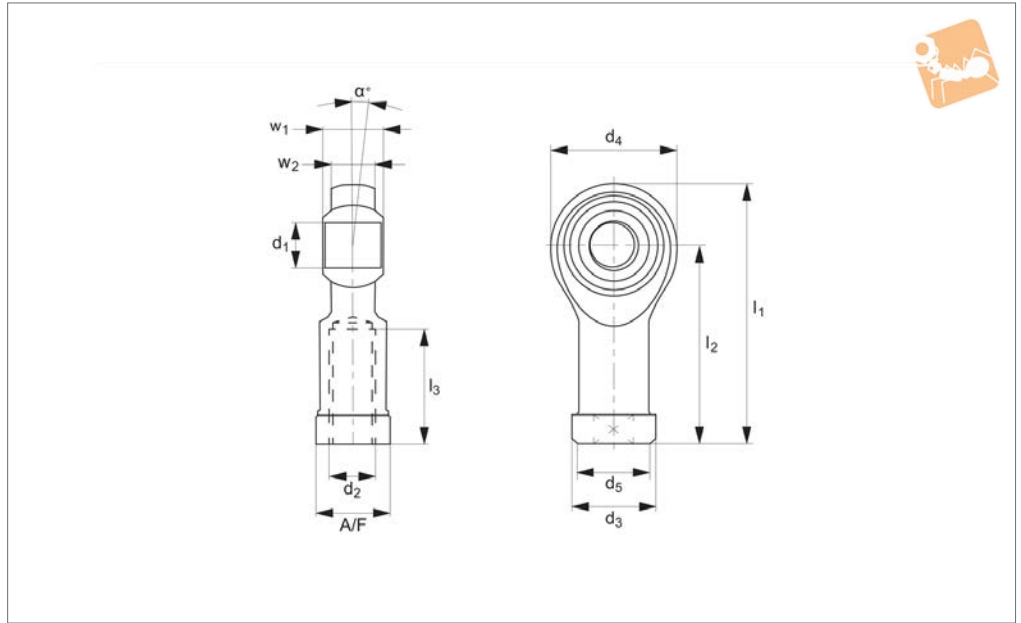

Material

Housing: stainless steel (AISI 316) Ball: Stainless steel, 1,4571 and polished stainless steel bearing rings.

Race: PTFE liner

series K, maintenance free.

Technical Notes

Standard thread is right hand thread,

Order No.	Thread hand	d ₁ tol. H7	l ₁	d ₂	d ₃	d ₄	d ₅	l ₂	l ₃	w ₁	w ₂	α	A/F	Static load C ₀ kN max.	Weight g
R3576.R005-A4	Right	5	36	M 5	18	11	8.5	27	10	8	6.00	13	9	4.8	16
R3576.R006-A4	Right	6	40	M 6	20	13	10	30	12	9	6.75	13	11	6.2	22
R3576.R008-A4	Right	8	48	M 8	16	24	12.5	36	16	12	9.00	14	14	10.3	47
R3576.R010-A4	Right	10	57	M10	28	19	15	43	20	14	10.50	13	17	14.4	77
R3576.R012-A4	Right	12	66	M12	32	22	17.5	50	22	16	12.00	13	19	19.2	100
R3576.R016-A4	Right	16	85	M16	42	27	22	64	28	21	15.00	15	22	31.2	220
R3576.L005-A4	Left	5	36	M 5	18	11	8.5	27	10	8	6.00	13	9	4.8	16
R3576.L006-A4	Left	6	40	M 6	20	13	10	30	12	9	6.75	13	11	6.2	22
R3576.L008-A4	Left	8	48	M 8	16	24	12.5	36	16	12	9.00	14	14	10.3	47
R3576.L010-A4	Left	10	57	M10	28	19	15	43	20	14	10.50	13	17	14.4	77
R3576.L012-A4	Left	12	66	M12	32	22	17.5	50	22	16	12.00	13	19	19.2	100
R3576.L016-A4	Left	16	85	M16	42	27	22	64	28	21	15.00	15	22	31.2	220



Imperial Low Cost Rod End

Male, with Nylon bearing race

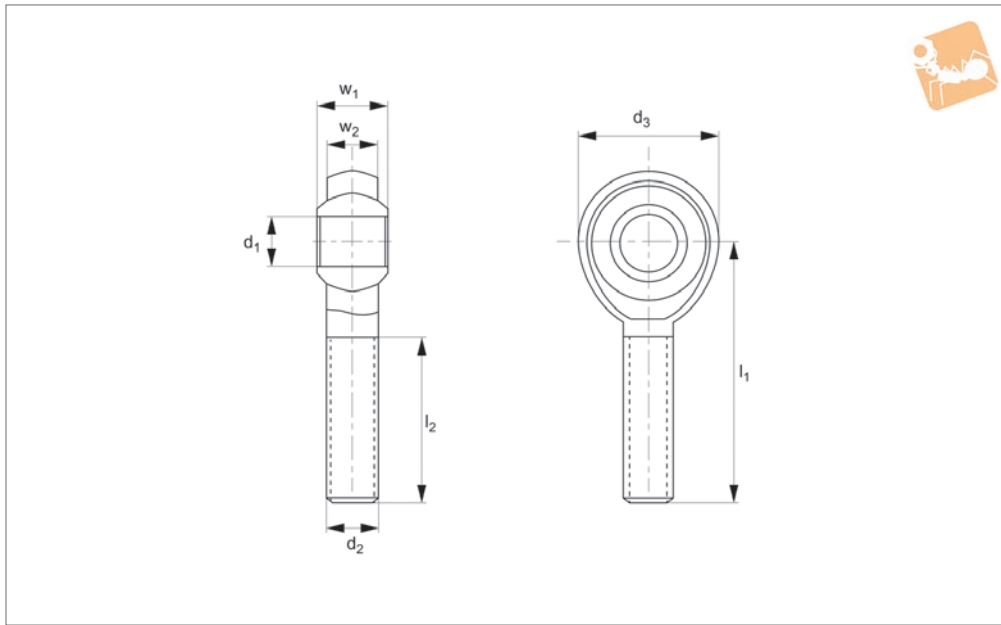

R3578.mi

ROD ENDS

Material

Housing: Yellow zinc plated steel.
Ball: Zinc plated, surface hardened steel.

Technical Notes

Features a reinforced nylon race that is

injection molded between the ball and forged housing.
The nylon race resists vibration, exhibits low hygroscopic properties and helps dampen structural vibration and noise.

As per SAE specification J1120 type B, yellow zinc is not RoHS Compliant.

Tips

Standard thread is right hand thread.

Order No.	Thread hand	d ₁	l ₁	d ₂	d ₃	l ₂	w ₁	w ₂
R3578.MIR190	Right	0.190	1.250	10-32	0.625	0.750	0.312	0.250
R3578.MIR250	Right	0.251	1.562	1/4-28	0.750	1.000	0.375	0.281
R3578.MIR313	Right	0.3135	1.875	5/16-24	0.875	1.250	0.437	0.344
R3578.MIR375	Right	0.376	2.000	3/8-24	1.090	1.250	0.500	0.406
R3578.MIR500	Right	0.501	2.437	1/2-20	1.380	1.500	0.625	0.500
R3578.MIR625	Right	0.626	2.625	5/8-18	1.500	1.625	0.750	0.562
R3578.MIR750	Right	0.751	2.875	3/4-16	1.750	1.750	0.875	0.687
R3578.MIL375	Left	0.376	2.000	3/8-24	1.090	1.250	0.500	0.406
R3578.MIL500	Left	0.501	2.437	1/2-20	1.380	1.500	0.625	0.500
R3578.MIL190	Left	0.190	1.250	10-32	0.625	0.750	0.312	0.250
R3578.MIL250	Left	0.251	1.562	1/4-28	0.750	1.000	0.375	0.280
R3578.MIL625	Left	0.626	2.625	5/8-18	1.500	1.625	0.750	0.562
R3578.MIL313	Left	0.3135	1.875	5/16-24	0.875	1.250	0.437	0.344
R3578.MIL750	Left	0.751	2.875	3/4-16	1.750	1.750	0.875	0.687



R3579

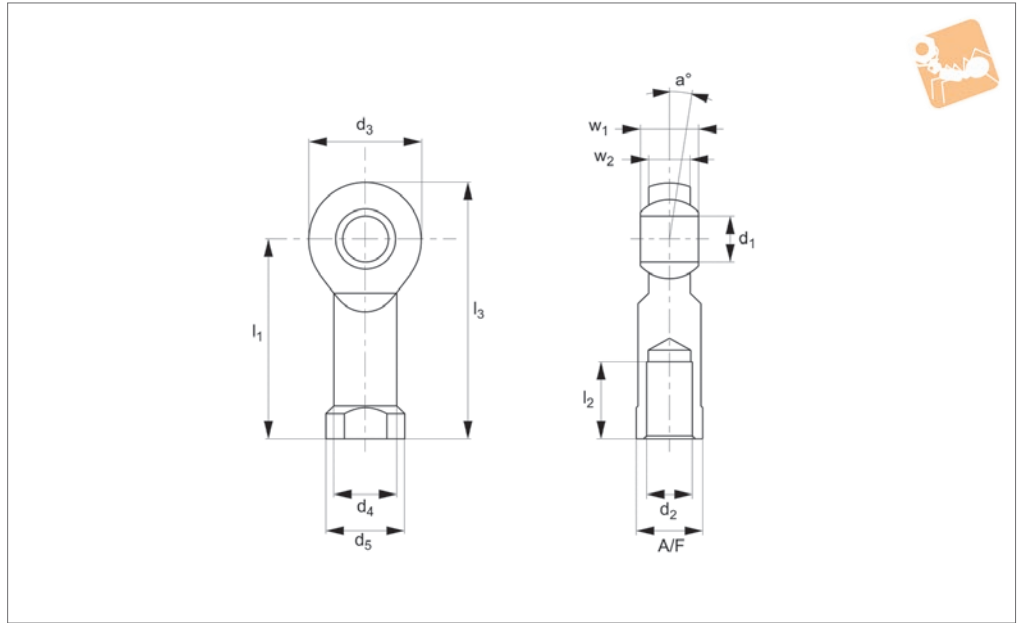

Material

Housing: Black plastic (Igumid G)
Spherical bearing: Iglidur w300.

Technical Notes

Resistant to corrosion and chemicals, standard thread is right hand thread.

High vibration dampening capacity

suitable for rotating, oscillating and linear movements.

Available with a metal sleeve to take a higher torque (Add -MS to part No.).

Important Notes

Dimensional series K according to standard DIN ISO 12240. *Denotes fine pitch thread. Short term max axial strength is up to 20 minutes. Any length of time greater than this is considered long term.

Order No.	Thread hand	d ₁ tol. E10	l ₁	d ₂	d ₃	d ₄	d ₅	l ₂	l ₃	w ₁	w ₂
R3579.R002	Right	2	12.5	M2	9	4.0	4.6	6	17	4	3.0
R3579.R003	Right	3	18.5	M3	13	6.5	8.0	8	25	6	4.5
R3579.R004	Right	5	27	M4	18	9.0	12.0	10	36	8	6.0
R3579.R005	Right	5	27	M5	18	9.0	12.0	10	36	8	6.0
R3579.R006	Right	6	30	M6	20	10.0	13.0	12	40	9	7.0
R3579.R008	Right	8	36	M8	24	13.0	16.0	16	48	12	9.0
R3579.R010	Right	10	43	M10	30	15.0	19.0	20	58	14	10.5
R3579.R011	Right	10	43	M10 x 1,25*	30	15.0	19.0	20	58	14	10.5
R3579.R012	Right	12	50	M12	34	18.0	22.0	22	67	16	12.0
R3579.R013	Right	12	50	M12 x 1,25*	34	18.0	22.0	22	67	16	12.0
R3579.R014	Right	14	57	M14	38	20.0	25.0	25	76	19	13.5
R3579.R016	Right	16	64	M16	42	22.0	27.0	28	85	21	15.0
R3579.R017	Right	16	64	M16 x 1,5*	42	22.0	27.0	28	85	21	15.0
R3579.R018	Right	18	71	M18 x 1,5*	46	25.0	31.0	32	94	23	16.5
R3579.R020	Right	20	77	M20 x 1,5*	50	28.0	34.0	33	102	25	18.0
R3579.R021	Right	20	77	M20 x 2,5	50	28.0	34.0	33	102	25	18.0
R3579.R022	Right	22	84	M22 x 1,5*	56	30.0	37.0	37	112	28	20.0
R3579.R025	Right	25	94	M24 x 2*	60	32.0	41.0	94	124	31	22.0
R3579.R030	Right	30	110	M30 x 2*	70	37.0	50.0	51	145	37	25.0
R3579.L002	Left	2	12.5	M2	9	4.0	4.6	6	17	6	3.0
R3579.L003	Left	3	18.5	M3	13	6.5	8.0	8	25	8	4.5
R3579.L004	Left	5	27	M4	18	9.0	12.0	10	36	10	6.0
R3579.L005	Left	5	27	M5	18	9.0	12.0	10	36	10	6.0
R3579.L006	Left	6	30	M6	20	10.0	13.0	12	40	12	7.0
R3579.L008	Left	8	36	M8	24	13.0	16.0	16	48	16	9.0
R3579.L010	Left	10	43	M10	30	15.0	19.0	20	58	20	10.5
R3579.L011	Left	10	43	M10 x 1,25*	30	15.0	19.0	20	58	20	10.5
R3579.L012	Left	12	50	M12	34	18.0	22.0	22	67	22	12.0
R3579.L013	Left	12	50	M12 x 1,25*	34	18.0	22.0	22	67	22	12.0
R3579.L014	Left	14	57	M14	38	20.0	25.0	25	76	25	13.5
R3579.L016	Left	16	64	M16	42	22.0	27.0	28	85	28	15.0



Plastic Rod End Female

Rod Ends

Order No.	Thread hand	d ₁ tol. E10	l ₁	d ₂	d ₃	d ₄	d ₅	l ₂	l ₃	w ₁	w ₂
R3579.L017	Left	16	64	M16 x 1,5*	42	22.0	27.0	28	85	28	15.0
R3579.L018	Left	18	71	M18 x 1,5*	46	25.0	31.0	32	94	32	16.5
R3579.L020	Left	20	77	M20 x 1,5*	50	28.0	34.0	33	102	33	18.0
R3579.L021	Left	20	77	M20 x 2,5	50	28.0	34.0	33	102	33	18.0
R3579.L022	Left	22	84	M22 x 1,5*	56	30.0	37.0	37	112	37	20.0
R3579.L025	Left	25	94	M24 x 2*	60	32.0	41.0	42	124	42	22.0
R3579.L030	Left	30	110	M30 x 2*	70	37.0	50.0	51	110	51	25.0

Order No.	A/F	α	Static strength (long term) N max.	Radial load (short term) N max.	Radial load (long term) N max.	Static strength (short term) N max.	Thread depth min.	Torque strength in thread max.	Torque through ball max.	Torque through ball MS Nm max.
R3579.R002	04	15	200	50	25	200	4	0.30	1	2
R3579.R003	06	15	100	400	50	800	5	0.50	2	4
R3579.R004	09	15	500	250	125	1000	7	0.75	5	12
R3579.R005	09	15	500	250	125	1000	7	1.00	5	12
R3579.R006	11	14.5	700	400	200	1400	8	1.50	10	15
R3579.R008	14	12.5	1050	700	350	2100	11	10.0	12	40
R3579.R010	17	12.5	1550	800	400	3100	13	15.0	20	50
R3579.R011	17	12.5	1550	800	400	3100	13	6.00	20	50
R3579.R012	19	12.5	1800	900	450	3600	15	20.0	30	70
R3579.R013	19	12,5°	1800	900	450	3600	15	15.0	30	70
R3579.R014	22	11.5	2000	1000	500	4000	17	25.0	35	75
R3579.R016	22	11.5	2100	1300	650	4200	19	30.0	40	110
R3579.R017	22	11.5	2100	1300	650	4200	19	27.5	40	110
R3579.R018	27	11.5	2300	1600	800	4600	21	45.0	45	150
R3579.R020	30	11.5	2700	2100	1050	5400	22	60.0	55	200
R3579.R021	30	11.5	2700	2100	1050	5400	22	60.0	55	200
R3579.R022	32	11	3500	2200	1100	7000	25	75.0	60	225
R3579.R025	36	11	4250	2300	1150	8500	28	120.0	60	260
R3579.R030	41	11	5250	2500	1250	10500	34	135.0	60	300
R3579.L002	04	15	200	50	25	200	4	0.30	1	2
R3579.L003	06	15	100	400	50	800	5	0.50	2	4
R3579.L004	09	15	500	250	125	1000	7	0.75	5	12
R3579.L005	09	15	500	250	125	1000	7	1.00	5	12
R3579.L006	11	14.5	700	400	200	1400	8	1.50	10	15
R3579.L008	14	12.5	1050	700	350	2100	11	10.0	12	40
R3579.L010	17	12.5	1550	800	400	3100	13	15.0	20	50
R3579.L011	17	12.5	1550	800	400	3100	13	6.00	20	50
R3579.L012	19	12.5	1800	900	450	3600	15	20.0	30	70
R3579.L013	19	12.5	1800	900	450	3600	15	15.0	30	70
R3579.L014	22	11.5	2000	1000	500	4000	17	25.0	35	75
R3579.L016	22	11.5	2100	1300	650	4200	19	30.0	40	110
R3579.L017	22	11.5	2100	1300	650	4200	19	27.5	40	110
R3579.L018	27	11.5	2300	1600	800	4600	21	45.0	45	150
R3579.L020	30	11.5	2700	2100	1050	5400	22	60.0	55	200
R3579.L021	30	11.5	2700	2100	1050	5400	22	60.0	55	200
R3579.L022	32	11	3500	2200	1100	7000	25	75.0	60	225
R3579.L025	36	11	4250	2300	1150	8500	28	120.0	60	260
R3579.L030	41	11	5250	2500	1250	10500	34	135.0	60	300

ROD ENDS



R3582

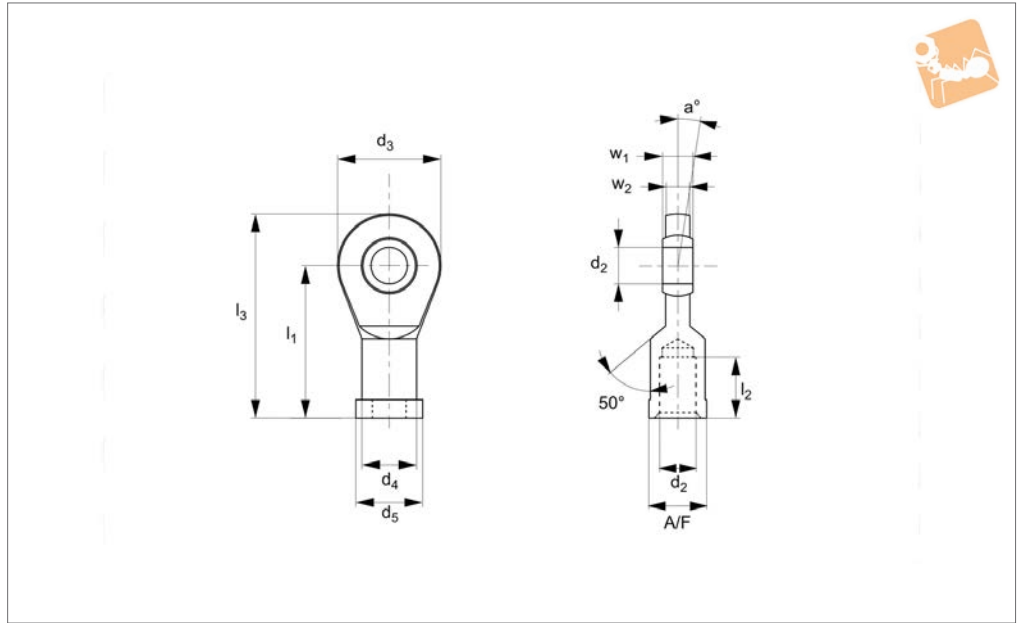

Material

Housing: Black plastic (Igumid G)
Spherical Bearing: Iglidur w300

Technical Notes

Maintenance free, self lubricating. High strength under impact loads. Very high tensile strength for varying loads. Resistant to dirt and dust, resistant to

corrosion and chemicals, standard thread is right hand thread.

High vibration dampening capacity, suitable for rotating, oscillating and linear movements.

Available with a metal sleeve to take a higher torque, (add -MS to part No.) Suitable for use with R3409 clevis joints.

Important Notes

Dimensional series E. *Denotes fine pitch thread.

Short term max axial strength is up to 20 minutes. Any length of time greater than this is considered long term.

Order No.	Thread hand	d ₁ tol. ±10	l ₁	d ₂	d ₃	d ₄	d ₅	l ₂	l ₃	w ₁	w ₂
R3582.R004	Right	4	22.5	M4	15	8.0	9.2	9.5	30.0	5	3.5
R3582.R005	Right	5	30.0	M5	19	9.0	11	12	39.5	6	4.4
R3582.R006	Right	6	30.0	M6	21	11.0	13	12	40.5	6	4.4
R3582.R008	Right	8	36.0	M8	24	13.0	16	16	48.0	8	6.0
R3582.R010	Right	10	43.0	M10	29	15.0	19	18	57.5	9	7.0
R3582.R011	Right	10	43.0	M10 x 1,25*	29	15.0	19	18	57.5	9	7.0
R3582.R012	Right	12	50.0	M12	34	18.0	22	20	67.0	10	8.0
R3582.R013	Right	12	50.0	M12 x 1,25*	34	18.0	22	20	67.0	10	8.0
R3582.R015	Right	15	61.0	M14	40	21.0	26	26	81.0	12	10.0
R3582.R017	Right	17	67.0	M16	46	24.0	30	27	90.0	14	11.0
R3582.R018	Right	17	67.0	M16 x 1,5*	46	24.0	30	27	90.0	14	11.0
R3582.R020	Right	20	77.0	M20 x 1,5*	53	27.0	34	31	103.5	16	13.0
R3582.R021	Right	20	77.0	M20 x 2,5	53	27.0	34	31	103.5	16	13.0
R3582.R025	Right	25	94.0	M24 x 2*	64	34.0	41	38	126.5	20	17.0
R3582.R030	Right	30	110.0	M30 x 2*	73	41.0	48	47	146.5	22	19.0
R3582.L004	Left	4	22.5	M4	15	8.0	9.2	9.5	30.0	5	3.5
R3582.L005	Left	5	30.0	M5	19	9.0	11	12	39.5	6	4.4
R3582.L006	Left	6	30.0	M6	21	11.0	13	12	40.5	6	4.4
R3582.L008	Left	8	36.0	M8	24	13.0	16	16	48.0	8	6.0
R3582.L010	Left	10	43.0	M10	29	15.0	19	18	57.5	9	7.0
R3582.L011	Left	10	43.0	M10 x 1,25*	29	15.0	19	18	57.5	9	7.0
R3582.L012	Left	12	50.0	M12	34	18.0	22	20	67.0	10	8.0
R3582.L013	Left	12	50.0	M12 x 1,25*	34	18.0	22	20	67.0	10	8.0
R3582.L015	Left	15	61.0	M14	40	21.0	26	26	81.0	12	10.0
R3582.L017	Left	17	67.0	M16	46	24.0	30	27	90.0	14	11.0
R3582.L018	Left	17	67.0	M16 x 1,5*	46	24.0	30	27	90.0	14	11.0
R3582.L020	Left	20	77.0	M20 x 1,5*	53	27.0	34	31	103.5	16	13.0
R3582.L021	Left	20	77.0	M20 x 2,5	53	27.0	34	31	103.5	16	13.0
R3582.L025	Left	25	94.0	M24 x 2*	64	34.0	41	38	126.5	20	17.0



Plastic Rod End Female

Rod Ends

Order No.	Thread hand	d_1 tol. E10	l_1	d_2	d_3	d_4	d_5	l_2	l_3	w_1	w_2
R3582.L030	Left	30	110.0	M30 x 2*	73	41.0	48	47	146.5	22	19.0

Order No.	A/F	a	Static strength (long term) N max.	Radial load (short term) N max.	Radial load (long term) N max.	Static strength (short term) N max.	Thread depth min.	Torque inside thread Nm max.	Torque through ball Nm max.
R3582.R004	08	16.5	400	100	50	800	7	0.4	2.0
R3582.R005	09	16.5	650	150	75	1300	8	0.5	2.0
R3582.R006	11	13.5	750	200	100	1500	8	1.5	2.5
R3582.R008	14	12	1000	450	225	2000	11	5.0	7.0
R3582.R010	17	12	1150	500	250	2300	13	15.0	14.0
R3582.R011	17	12	1150	500	250	2300	13	6.0	14.0
R3582.R012	19	10.5	1650	550	275	3300	14	20.0	25.0
R3582.R013	19	10.5	1650	550	275	3300	14	15.0	25.0
R3582.R015	22	10.5	2400	800	400	4800	18	25.0	30.0
R3582.R017	27	9	2650	1100	550	5300	19	30.0	35.0
R3582.R018	27	9	2650	1100	550	5300	19	27.5	35.0
R3582.R020	30	8	3600	1800	900	7200	22	60.0	40.0
R3582.R021	30	8	3600	1800	900	7200	22	60.0	40.0
R3582.R025	36	8	5000	2600	1300	10000	27	115.0	55.0
R3582.R030	41	6.5	5250	3000	1300	10500	33	130.0	70.0
R3582.L004	08	16.5	400	100	50	800	7	0.4	2.0
R3582.L005	09	16.5	650	150	75	1300	8	0.5	2.0
R3582.L006	11	13.5	750	200	100	1500	8	1.5	2.5
R3582.L008	14	12	1000	450	225	2000	11	5.0	7.0
R3582.L010	17	12	1150	500	250	2300	13	15.0	14.0
R3582.L011	17	12	1150	500	250	2300	13	6.0	14.0
R3582.L012	19	10.5	1650	550	275	3300	14	20.0	25.0
R3582.L013	19	10.5	1650	550	275	3300	14	15.0	25.0
R3582.L015	22	10.5	2400	800	400	4800	18	25.0	30.0
R3582.L017	27	9	2650	1100	550	5300	19	30.0	35.0
R3582.L018	27	9	2650	1100	550	5300	19	27.5	35.0
R3582.L020	30	8	3600	1800	900	7200	22	60.0	40.0
R3582.L021	30	8	3600	1800	900	7200	22	60.0	40.0
R3582.L025	36	8	5000	2600	1300	10000	27	115.0	55.0
R3582.L030	41	6.5	5250	3000	1300	10500	33	130.0	70.0

ROD ENDS



R3610

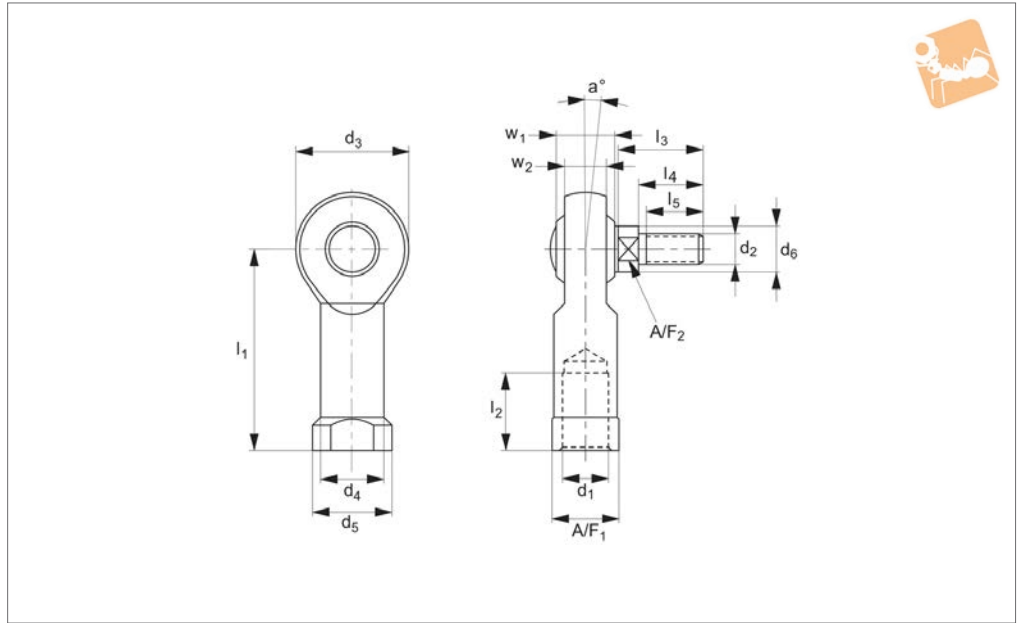

Material

Body: surface zinc plated
 Race: steel/ bronze - PTFE composite.
 Inner ring: bearing steel, hardened ground and spherical surface chromium plates.
 Outer ring: brass body pressed around,

outer race lined with bronze - PTFE composite.

Technical Notes

Maintenance free. Sizes according to DIN ISO 12240-4 series K.

Tips

Standard thread is right hand thread.
 Rod end studs are all right hand threads.

Important Notes

*Denotes fine pitch threads.

Order No.	Thread hand	d ₁	d ₂	l ₁	w ₁	d ₃	d ₄	d ₅	d ₆	l ₂	Weight g
R3610.R006	Right	M6	M6	30	9	20	10.0	13	9.0	12	22
R3610.R008	Right	M8	M8	36	12	24	12.5	16	10.5	16	47
R3610.R010	Right	M10	M10	43	14	28	15.0	19	13.0	20	77
R3610.R011	Right	M10 x 1,25*	M10	43	14	28	15.0	19	13.0	20	77
R3610.R012	Right	M12	M12	50	16	32	17.5	22	15.0	22	100
R3610.R013	Right	M12 x 1,25*	M12	50	16	32	17.5	22	15.0	22	100
R3610.R014	Right	M14	M14	57	19	36	20.0	25	17.0	25	160
R3610.R015	Right	M14 x 1,5*	M14	57	19	36	20.0	25	17.0	25	160
R3610.R016	Right	M16	M16	64	21	42	22.0	27	19.0	28	220
R3610.R017	Right	M16 x 1,5*	M16	64	21	42	22.0	27	19.0	28	220
R3610.L006	Left	M6	M6	30	9	20	10.0	13	9.0	12	22
R3610.L008	Left	M8	M8	36	12	24	12.5	16	10.5	16	47
R3610.L010	Left	M10	M10	43	14	28	15.0	19	13.0	20	77
R3610.L011	Left	M10 x 1,25*	M10	43	14	28	15.0	19	13.0	20	77
R3610.L012	Left	M12	M12	50	16	32	17.5	22	15.0	22	100
R3610.L013	Left	M12 x 1,25*	M12	50	16	32	17.5	22	15.0	22	100
R3610.L014	Left	M14	M14	57	19	36	20.0	25	17.0	25	160
R3610.L015	Left	M14 x 1,50*	M14	57	19	36	20.0	25	17.0	25	160
R3610.L016	Left	M16	M16	64	21	42	22.0	27	19.0	28	220
R3610.L017	Left	M16 x 1,50*	M16	64	21	42	22.0	27	19.0	28	220

Order No.	l ₃	l ₄	l ₅	w ₂	A/F ₁	A/F ₂	a °	Static load C ₀ kN max.
R3610.R006	18.5	13	10	6.75	11	8	13	7.7
R3610.R008	23.5	17	13	9.00	14	8	14	12.9
R3610.R010	28.0	21	17	10.50	17	12	13	18.0
R3610.R011	28.0	21	17	10.50	17	12	13	18.0
R3610.R012	32.5	25	20	12.00	19	14	13	24.0
R3610.R013	32.5	25	20	12.00	19	14	13	24.0
R3610.R014	37.5	29	22	13.50	22	14	16	31.0
R3610.R015	37.5	29	22	13.50	22	14	16	31.0



Rod End with Stud - Female

Rod Ends

Order No.	l_3	l_4	l_5	w_2	A/F_1	A/F_2	α	Static load C_0 kN max.
R3610.R016	42.5	33	24	15.00	22	17	15	39.0
R3610.R017	42.5	33	24	15.00	22	17	15	39.0
R3610.L006	18.5	13	10	6.75	11	8	13	7.7
R3610.L008	23.5	17	13	9.00	14	8	14	12.9
R3610.L010	28.0	21	17	10.50	17	12	13	18.0
R3610.L011	28.0	21	17	10.50	17	12	13	18.0
R3610.L012	32.5	25	20	12.00	19	14	13	24.0
R3610.L013	32.5	25	20	12.00	19	14	13	24.0
R3610.L014	37.5	29	22	13.50	22	14	16	31.0
R3610.L015	37.5	29	22	13.50	22	14	16	31.0
R3610.L016	42.5	33	24	15.00	22	17	15	39.0
R3610.L017	42.5	33	24	15.00	22	17	15	39.0



R3611

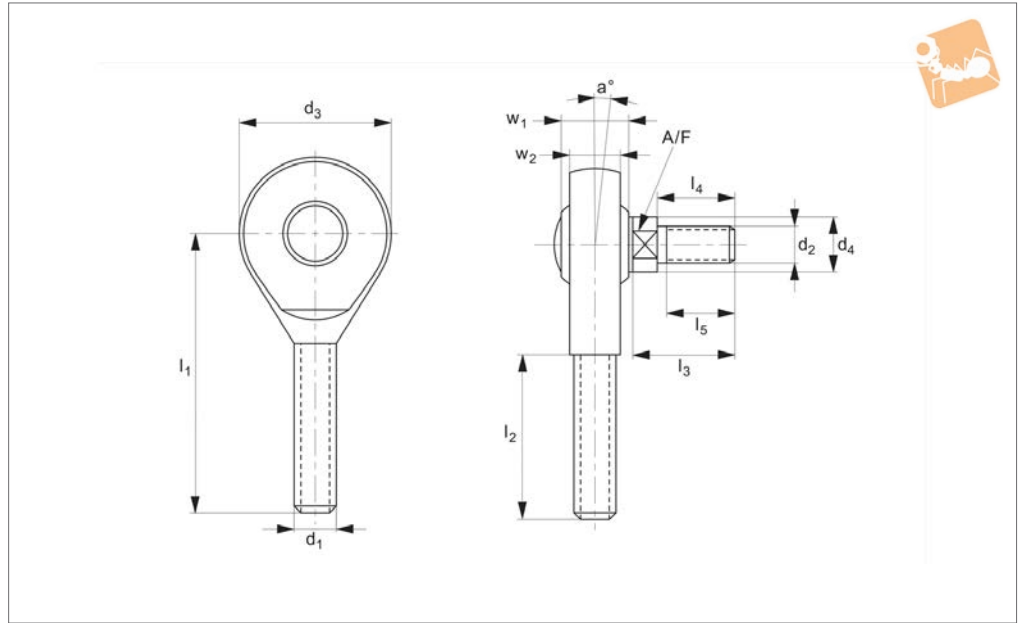

Material

Body: surface zinc plated.
 Race: steel/ bronze - PTFE composite.
 Inner ring: bearing steel, hardened ground and spherical surface chromium plates.
 Outer ring: brass body pressed around,

outer race lined with bronze - PTFE composite.

Technical Notes

Maintenance free, sizes according to DIN ISO 12230-4 series K.

Tips

Standard thread is right hand thread.
 Rod end studs are all right hand threads.

Order No.	Thread hand	d ₁	d ₂	l ₁	w ₁	d ₃	d ₄	l ₂	l ₃	Weight g
R3611.R006	Right	M6	M6	36	9	20	9.0	21	18.5	20
R3611.R008	Right	M8	M8	42	12	24	10.5	25	23.5	38
R3611.R010	Right	M10	M10	48	14	28	13.0	28	28.5	55
R3611.R012	Right	M12	M12	54	16	32	15.0	32	32.5	85
R3611.R014	Right	M14	M14	60	19	36	17.0	36	37.5	140
R3611.R016	Right	M16	M16	66	21	42	19.0	37	42.5	210
R3611.L006	Left	M6	M6	36	9	20	9.0	21	18.5	20
R3611.L008	Left	M8	M8	42	12	24	10.5	25	23.5	38
R3611.L010	Left	M10	M10	48	14	28	13.0	28	28.5	55
R3611.L012	Left	M12	M12	54	16	32	15.0	32	32.5	85
R3611.L014	Left	M14	M14	60	19	36	17.0	36	37.5	140
R3611.L016	Left	M16	M16	66	21	42	19.0	37	42.5	210

Order No.	l ₄	l ₅	w ₂	A/F	a°	Static load C ₀ kN max.
R3611.R006	13	10	6.75	8	13	7.7
R3611.R008	17	13	9.00	8	14	12.9
R3611.R010	21	17	10.50	12	13	18.0
R3611.R012	25	20	12.00	14	13	24.0
R3611.R014	29	22	13.50	14	16	31.0
R3611.R016	33	24	15.00	17	15	39.0
R3611.L006	13	10	6.75	8	13	7.7
R3611.L008	17	13	9.00	8	14	12.9
R3611.L010	21	17	10.50	12	13	18.0
R3611.L012	25	20	12.00	14	13	24.0
R3611.L014	29	22	13.50	14	16	31.0
R3611.L016	33	24	15.00	17	15	39.0



Stainless Rod End with Stud Female

Rod Ends



R3613

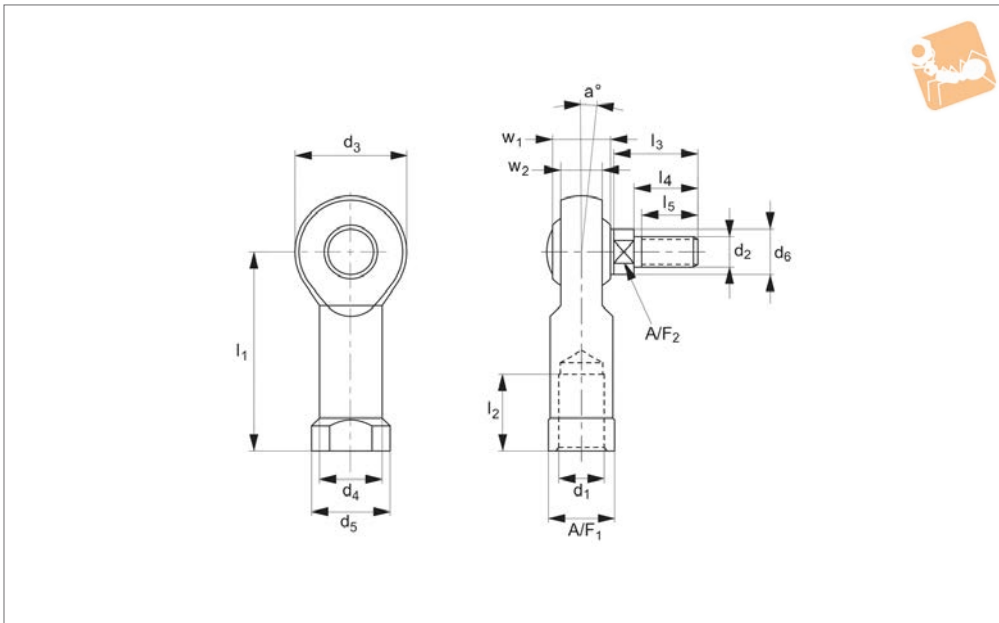

Material

Body: stainless steel (AISI 304)
 Race: steel/ bronze - PTFE composite.
 Inner ring: stainless steel, hardened and ground (AISI 304).
 Outer ring: brass body pressed around, outer race lined with bronze - PTFE compo-

site.
 Joint ball: stainless steel (AISI 440C)

Technical Notes

Maintenance free. Sizes according to DIN ISO 12740-4, series K

Tips

Standard thread is right hand thread.
 Rod end studs are all right hand threads.

Important Notes

*denotes fine pitch threads.

Order No.	Thread hand	d ₁	d ₂	l ₁	w ₁	d ₃	d ₄	d ₅	d ₆	l ₂	Weight g
R3613.R006	Right	M6	M6	30	9	20	10.0	13	9.0	12	22
R3613.R008	Right	M8	M8	36	12	24	12.5	16	10.5	16	47
R3613.R010	Right	M10	M10	43	14	28	15.0	19	13.0	20	77
R3613.R011	Right	M10 x 1,25*	M10	43	14	28	15.0	19	13.0	20	100
R3613.R012	Right	M12	M12	50	16	32	17.5	22	15.0	22	100
R3613.R013	Right	M12 x 1,25*	M12	50	16	32	17.5	22	15.0	22	100
R3613.R014	Right	M14	M14	57	19	36	20.0	25	17.0	25	160
R3613.R015	Right	M14 x 1,5*	M14	57	19	36	20.0	25	17.0	25	160
R3613.R016	Right	M16	M16	64	21	42	22.0	27	19.0	28	220
R3613.R017	Right	M16 x 1,5*	M16	64	21	42	22.0	27	19.0	28	220
R3613.L006	Left	M6	M6	30	9	20	10.0	13	9.0	12	22
R3613.L008	Left	M8	M8	36	12	24	12.5	16	10.5	16	47
R3613.L010	Left	M10	M10	43	14	28	15.0	19	13.0	20	77
R3613.L011	Left	M10 x 1,25*	M10	43	14	28	15.0	19	13.0	20	100
R3613.L012	Left	M12	M12	50	16	32	17.5	22	15.0	22	100
R3613.L013	Left	M12 x 1,25*	M12	50	16	32	17.5	22	15.0	22	100
R3613.L014	Left	M14	M14	57	19	36	20.0	25	17.0	25	160
R3613.L015	Left	M14 x 1,50*	M14	57	19	36	20.0	25	17.0	25	160
R3613.L016	Left	M16	M16	64	21	42	22.0	27	19.0	28	220
R3613.L017	Left	M16 x 1,50*	M16	64	21	42	22.0	27	19.0	28	220

Order No.	l ₃	l ₄	l ₅	w ₂	A/F ₁	A/F ₂	a°	Static load C ₀ kN max.
R3613.R006	18.5	13	10	6.75	11	8	13	7.7
R3613.R008	23.5	17	13	9.00	14	8	14	12.9
R3613.R010	28.0	21	17	10.50	17	12	13	18.0
R3613.R011	28.0	21	17	10.50	17	12	13	18.0
R3613.R012	32.5	25	20	12.00	19	14	13	24.0
R3613.R013	32.5	25	20	12.00	19	14	13	24.0



Order No.	l_3	l_4	l_5	w_2	A/F_1	A/F_2	a	Static load C_0 kN max.
R3613.R014	37.5	29	22	13.50	22	14	16	31.0
R3613.R015	37.5	29	22	13.50	22	14	16	31.0
R3613.R016	42.5	33	24	15.00	22	17	15	39.0
R3613.R017	42.5	33	24	15.00	22	17	15	39.0
R3613.L006	18.5	13	10	6.75	11	8	13	7.7
R3613.L008	23.5	17	13	9.00	14	8	14	12.9
R3613.L010	28.0	21	17	10.50	17	12	13	18.0
R3613.L011	28.0	21	17	10.50	17	12	13	18.0
R3613.L012	32.5	25	20	12.00	19	14	13	24.0
R3613.L013	32.5	25	20	12.00	19	14	13	24.0
R3613.L014	37.5	29	22	13.50	22	14	16	31.0
R3613.L015	37.5	29	22	13.50	22	14	16	31.0
R3613.L016	42.5	33	24	15.00	22	17	15	39.0
R3613.L017	42.5	33	24	15.00	22	17	15	39.0



Stainless Rod End with stud Male

Rod Ends

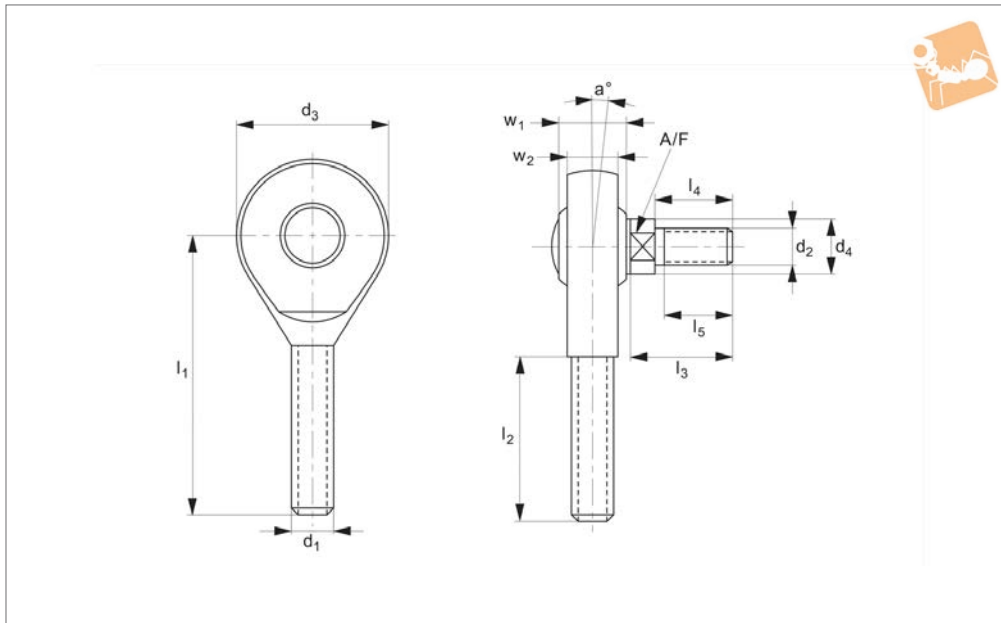

R3614

ROD ENDS

Material

Body: stainless steel (AISI 304)
Race: steel/ bronze - PTFE composite.
Inner ring: stainless steel, hardened and ground (AISI 304)
Outer ring: brass body pressed around,

outer race lined with bronze - PTFE composite.

Joint ball: stainless steel (AISI 440C)

Technical Notes

Maintenance free, sizes according to DIN

ISO 12240-4 series K.

Tips

Standard thread is right hand thread.
Rod end studs are all right hand threads.

Order No.	Thread hand	d ₁	d ₂	l ₁	w ₁	d ₃	d ₄	Weight g
R3614.R006	Right	M6	M6	36	9	20	9.0	20
R3614.R008	Right	M8	M8	42	12	24	10.5	38
R3614.R010	Right	M10	M10	48	14	28	13.0	55
R3614.R012	Right	M12	M12	54	16	32	15.0	85
R3614.R014	Right	M14	M14	60	19	36	17.0	140
R3614.R016	Right	M16	M16	66	21	42	19.0	210
R3614.L006	Left	M6	M6	36	9	20	9.0	20
R3614.L008	Left	M8	M8	42	12	24	10.5	38
R3614.L010	Left	M10	M10	48	14	28	13.0	55
R3614.L012	Left	M12	M12	54	16	32	15.0	85
R3614.L014	Left	M14	M14	60	19	36	17.0	140
R3614.L016	Left	M16	M16	66	21	42	19.0	210

Order No.	l ₂	l ₃	l ₄	l ₅	w ₂	A/F	a °	Static load C ₀ kN max.
R3614.R006	21	18.5	13	10	6.75	8	13	7.7
R3614.R008	25	23.5	17	13	9.00	8	14	12.9
R3614.R010	28	28.5	21	17	10.50	12	13	18.0
R3614.R012	32	32.5	25	20	12.00	14	13	24.0
R3614.R014	36	37.5	29	22	13.50	14	16	31.0
R3614.R016	37	42.5	33	24	15.00	17	15	39.0
R3614.L006	21	18.5	13	10	6.75	8	13	7.7
R3614.L008	25	23.5	17	13	9.00	8	14	12.9
R3614.L010	28	28.5	21	17	10.50	12	13	18.0
R3614.L012	32	32.5	25	20	12.00	14	13	24.0
R3614.L014	36	37.5	29	22	13.50	14	16	31.0
R3614.L016	37	42.5	33	24	15.00	17	15	39.0



R3616.i

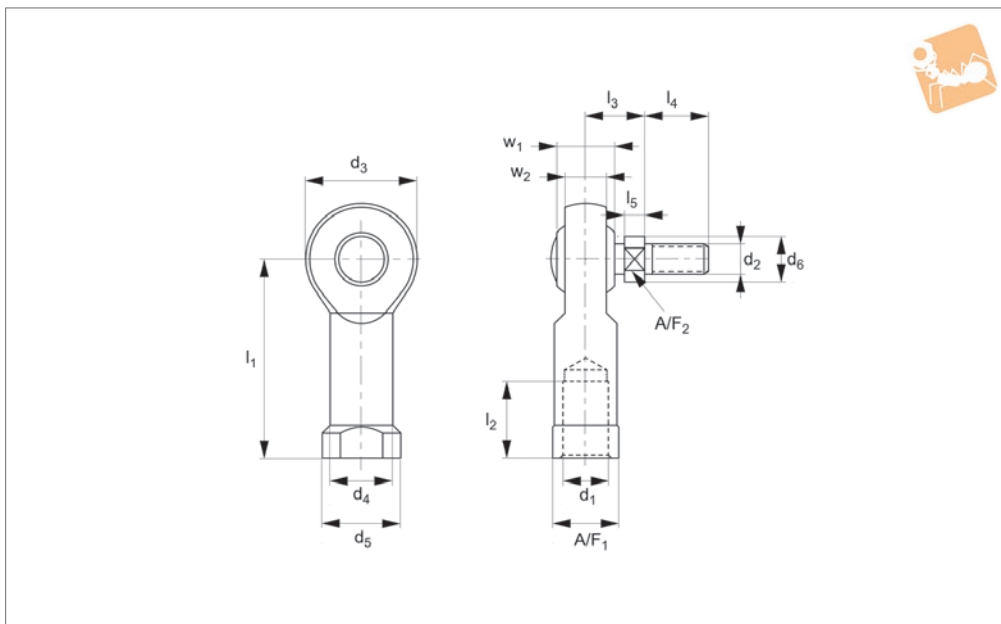

Material

Housing and Stud: Yellow zinc plated steel.
Ball: Zinc plated, surface hardened steel

forced nylon bearing race.
Female thread, Maintenance free, yellow zinc is not RoHS Compliant.

Rod end studs are all right hand threads.

Technical Notes

Features an injection molded, fibre rein-

Tips

Standard thread is Right hand thread.

Order No.	Thread hand	d ₁	d ₂	l ₁	w ₁	d ₃	d ₄
R3616.I190	Right	10-32	10-32	1.062	0.312	0.625	0.406
R3616.I250	Right	1/4-28	1/4-28	1.312	0.375	0.750	0.469
R3616.I313	Right	5/16-24	5/16-24	1.375	0.437	0.875	0.500
R3616.I375	Right	3/8-24	3/8-24	1.625	0.500	1.000	0.687
R3616.I500	Right	1/2-20	1/2-20	2.125	0.625	1.312	0.875
R3616.I625	Right	5/8-18	5/8-18	2.500	0.750	1.500	1.000
R3616.I750	Right	3/4-16	3/4-16	2.875	0.875	1.750	1.125
R3616.IL190	Left	10-32	10-32	1.062	0.312	0.625	0.406
R3616.IL250	Left	1/4-28	1/4-28	1.312	0.375	0.750	0.469
R3616.IL313	Left	5/16-24	5/16-24	1.375	0.437	0.875	0.500
R3616.IL375	Left	3/8-24	3/8-24	1.625	0.500	1.000	0.687
R3616.IL500	Left	1/2-20	1/2-20	2.125	0.625	1.312	0.875

Order No.	d ₅	l ₂	l ₃	l ₄	l ₅	w ₂	A/F ₁	A/F ₂	α
R3616.I190	0.187	0.562	0.437	0.437	0.125	0.250	0.312	0.321	25
R3616.I250	0.304	0.750	0.469	0.562	0.125	0.281	0.375	0.375	25
R3616.I313	0.356	0.750	0.531	0.687	0.125	0.344	0.437	0.437	25
R3616.I375	0.424	0.937	0.644	0.906	0.187	0.406	0.562	0.500	25
R3616.I500	0.564	1.187	0.875	1.125	0.250	0.500	0.750	0.625	25
R3616.I625	0.622	1.500	1.000	1.125	0.375	0.562	0.875	0.750	25
R3616.I750	0.747	1.562	1.187	1.812	0.375	0.687	1.000	1.000	25
R3616.IL190	0.187	0.562	0.437	0.437	0.125	0.250	0.312	0.321	25
R3616.IL250	0.304	0.750	0.469	0.562	0.125	0.281	0.375	0.375	25
R3616.IL313	0.356	0.750	0.531	0.687	0.125	0.344	0.437	0.437	25
R3616.IL375	0.424	0.937	0.644	0.906	0.187	0.406	0.562	0.500	25
R3616.IL500	0.564	1.187	0.875	1.125	0.250	0.500	0.750	0.625	25



Imperial Male Rod End with Stud with Nylon bearing race

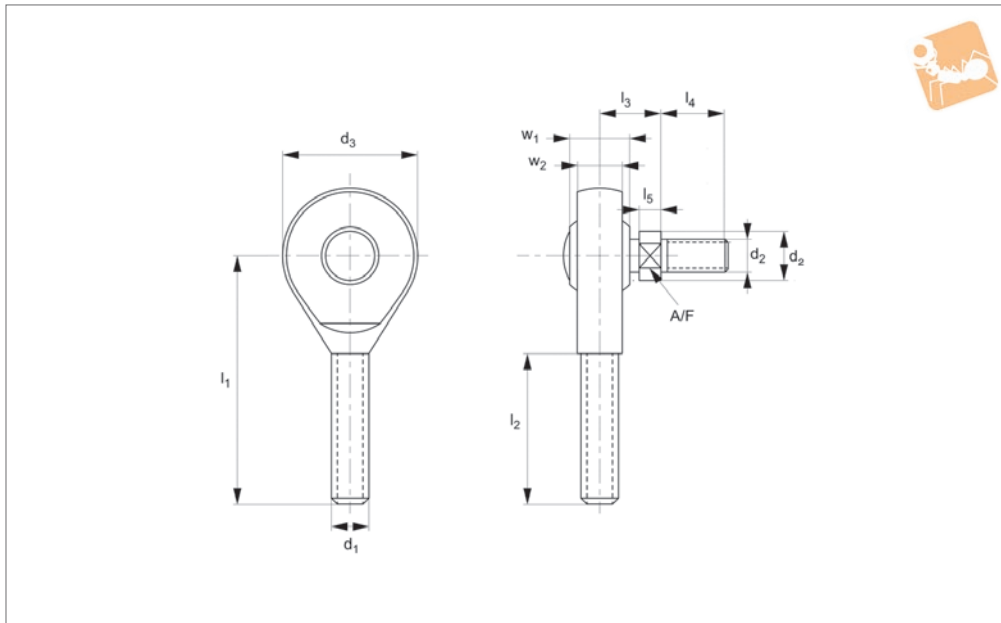

R3617.i

ROD ENDS

Material

Housing and Stud: Yellow zinc plated steel.
Ball: Zinc plated, surface hardened steel.

forced nylon bearing race.
Female thread, Maintenance free, yellow zinc is not RoHS Compliant.

end studs are all Right hand threads.

Technical Notes

Features an injection molded, fibre rein-

Tips

Standard thread is Right hand thread, rod

Order No.	Thread hand	d ₁	d ₂	l ₁	w ₁	d ₃	d ₄	l ₂	l ₃	l ₄	l ₅	w ₂	A/F	a _o
R3617.I250	Right	10-32	10-32	1.562	0.375	0.750	0.304	1.000	0.469	0.562	0.125	0.281	0.375	25
R3617.I313	Right	5/16-24	5/16-24	1.875	0.437	0.875	0.356	1.250	0.531	0.687	0.125	0.344	0.437	25
R3617.I375	Right	3/8-24	3/8-24	2.000	0.500	1.090	0.424	1.250	0.644	0.906	0.187	0.406	0.500	25
R3617.I500	Right	1/2-20	1/2-20	2.437	0.625	1.380	0.564	1.500	0.875	1.125	0.250	0.500	0.625	25
R3617.I625	Right	5/8-18	5/8-18	2.625	0.750	1.500	0.622	1.625	1.000	1.125	0.375	0.562	0.750	25
R3617.I750	Right	3/4-16	3/4-16	2.875	0.875	1.750	0.747	1.750	1.187	1.812	0.375	0.687	1.000	25
R3617.IL250	Left	10-32	10-32	1.562	0.375	0.750	0.304	1.000	0.469	0.562	0.125	0.281	0.375	25
R3617.IL313	Left	5/16-24	5/16-24	1.875	0.437	0.875	0.356	1.250	0.531	0.687	0.125	0.344	0.437	25
R3617.IL375	Left	3/8-24	3/8-24	2.000	0.500	1.090	0.424	1.250	0.644	0.906	0.187	0.406	0.500	25
R3617.IL500	Left	1/2-20	1/2-20	2.437	0.625	1.380	0.564	1.500	0.875	1.125	0.250	0.500	0.625	25

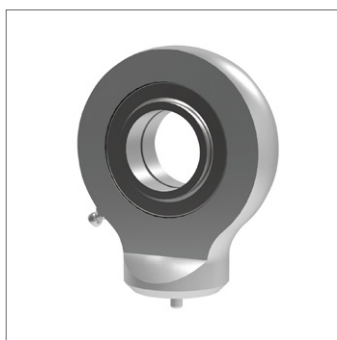

R3620

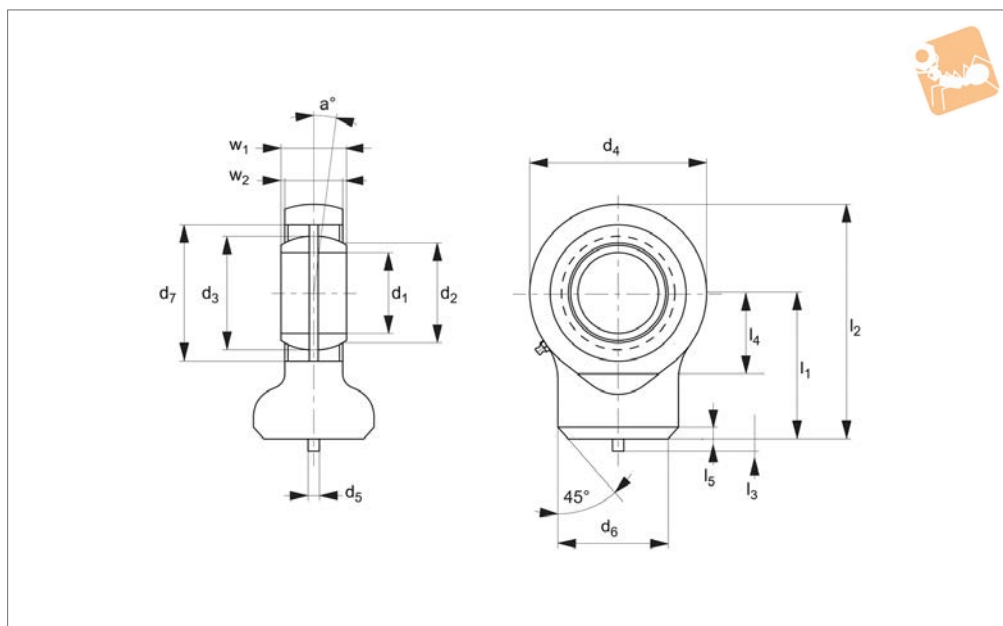

Material

Housing: forged steel (st 52-3).
Steel on steel bearing requiring lubrication.

Spherical plain bearing.

Technical Notes

Sizes up to 12 not regreasable, rod ends

series E to DIN ISO 12240-4.

Tips

For weld-on piston rod ends.

Order No.	d ₁	l ₁	d ₂	d ₃	d ₄	d ₅	d ₆	d ₇	Weight g
R3620.010	10	24	13.2	16	29	3	15	19	41
R3620.012	12	27	15	18	34	3	17.5	22	66
R3620.015	15	31	18.4	22	40	4	21	26	120
R3620.017	17	35	20.7	25	46	4	24	30	190
R3620.020	20	38	24.2	29	53	4	27.5	35	230
R3620.025	25	45	29.3	35.5	64	4	35.5	42	430
R3620.030	30	51	34.2	40.7	73	4	40	47	640
R3620.035	35	61	39.8	47	82	4	47	55	960
R3620.040	40	69	45.0	53	92	4	52	62	1300
R3620.045	45	77	50.8	60	102	6	58	68	1800
R3620.050	50	88	55.9	66	112	6	62	75	2500
R3620.060	60	100	66.8	80	135	6	70	90	3900
R3620.070	70	115	77.9	92	160	6	80	105	6600
R3620.080	80	141	89.4	105	180	6	95	120	8700

Order No.	Dyn. load C ₀ N max.	l ₂	l ₃	l ₄	l ₅	Static load C ₀ kN max.	w ₁	w ₂	a°
R3620.010	8.15	38.5	6	15.0	2	12.48	9	7	12
R3620.012	10.8	44	6	18.0	2	17.28	10	8	11
R3620.015	17.00	51	6	20.0	2.5	25.60	12	10	8
R3620.017	21.20	58	6	23.0	3	32.00	14	11	10
R3620.020	30.00	64.5	6	27.5	3	43.20	16	13	9
R3620.025	48.00	77	6	33	4	57.60	20	17	7
R3620.030	62.00	87.5	6	37.5	4	76.00	22	19	6
R3620.035	80.00	102	6	43	4	100.00	25	21	6
R3620.040	100.00	115	6	48	5	124.80	28	23	7
R3620.045	127.00	128	6	52.0	5	166.40	32	27	7
R3620.050	156.00	144	6	59.0	6	200.00	35	30	6
R3620.060	245.00	167.5	6	72.5	8	312.00	44	38	6
R3620.070	315.00	195	6	86	10	408.00	49	42	6
R3620.080	400.00	231	6	98	10	496.00	55	47	6

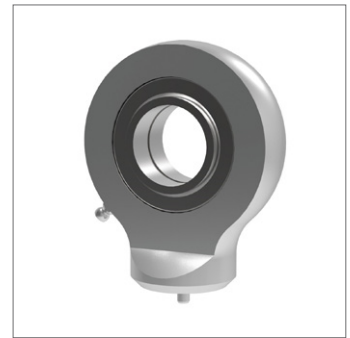
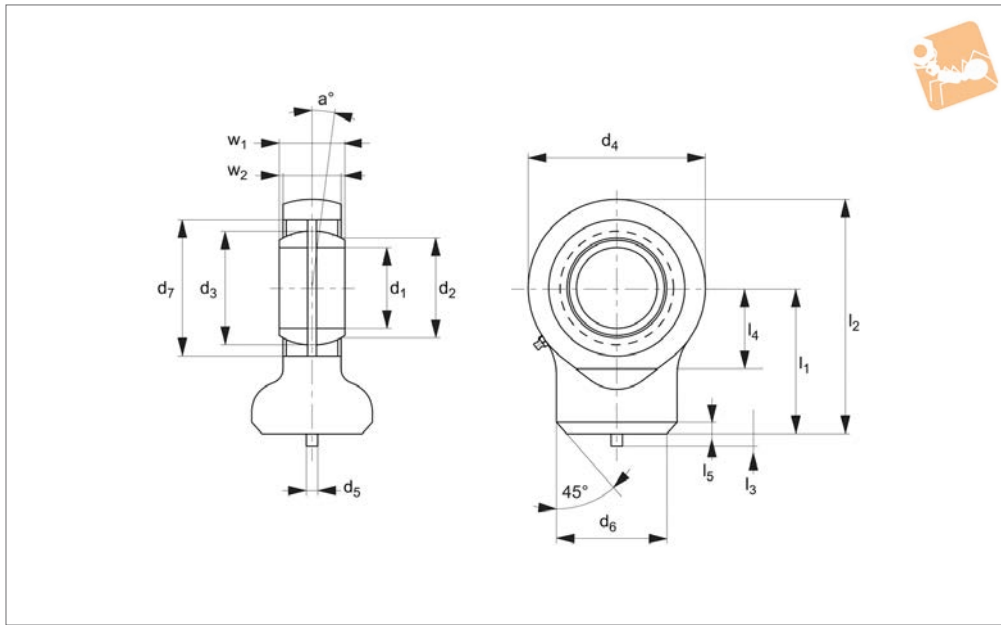

R3621

ROD ENDS

Material

PTFE fabric.

Housing: stainless steel (AISI 316).

Bearing stainless steel (AISI 420C) and

Order No.	d ₁ tol. M7	l ₁	d ₂	d ₃	d ₄	d ₅	d ₆	d ₇	Weight g
R3621.020	20	38	24.1	29	53	4	27.5	35	250
R3621.025	25	45	29.3	35.5	64	4	33.5	42	450
R3621.030	30	51	34.2	40.7	73	4	40	47	675
R3621.035	35	61	39.7	47	82	4	47	55	950
R3621.040	40	69	45.0	53	92	4	52	62	1400
R3621.045	45	77	50.7	60	102	6	58	68	1910
R3621.050	50	88	56.0	66	112	6	62	75	2650

Order No.	Dyn. load C ₀ N max.	l ₂	l ₃	l ₄	l ₅	Static load C ₀ N max.	w ₁	w ₂	a °
R3621.020	30.00	64.5	6	27.5	3	54.00	16	13	9
R3621.025	48.00	77	6	33	4	72.00	20	17	7
R3621.030	62.00	87.5	6	37.5	4	95.00	22	19	6
R3621.035	80.00	102	6	43	4	125.00	25	21	6
R3621.040	100.00	115	6	48	5	156.00	28	23	7
R3621.045	127.00	128	6	52.0	5	208.00	32	27	7
R3621.050	156.00	144	6	59.0	6	250.00	35	30	6

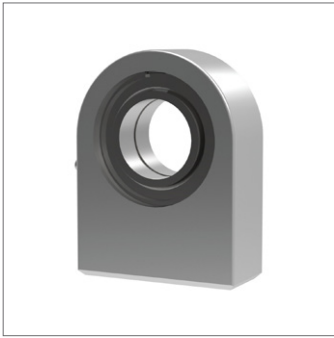

R3622

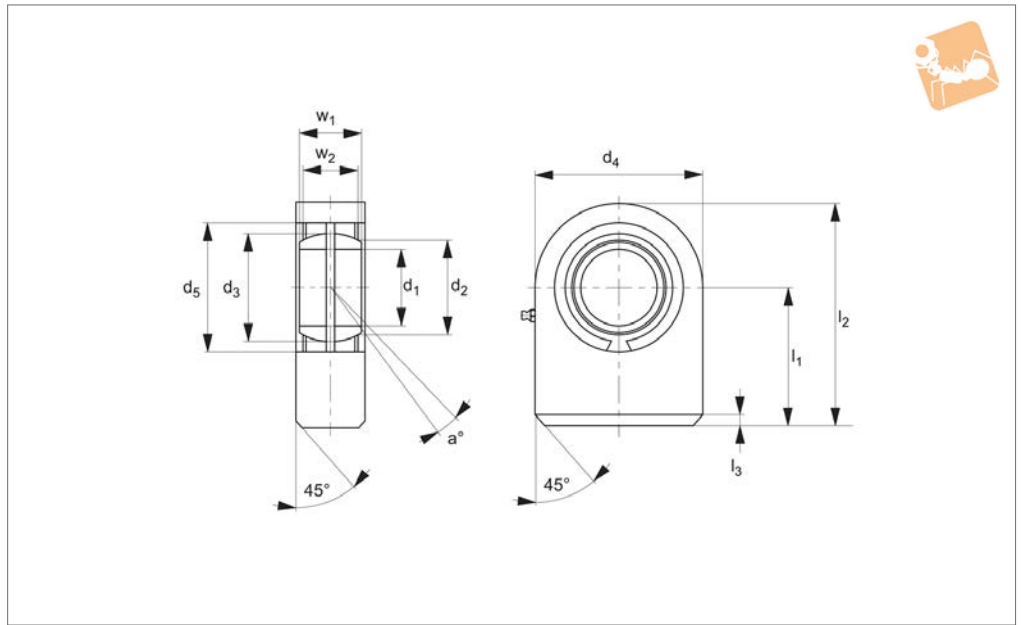

Material

Housing: forged steel (st 52-3), steel on steel bearing requiring lubrication, spherical plain bearing.

71412

Tips

Rod ends with rectangular surface for weld-on, spherical plain bearings fixed with snap rings.

Technical Notes

Fitted with hydraulic grease nipple to DIN

Order No.	d ₁ tol. M7	l ₁	d ₂	d ₃	d ₄	d ₅	Weight g
R3622.020	20	38	24.1	29.0	50	35	350
R3622.025	25	45	29.3	35.5	55	42	530
R3622.030	30	51	34.2	40.7	65	47	870
R3622.035	35	61	39.7	47.0	83	55	1500
R3622.040	40	69	45	53.0	100	62	2400
R3622.045	45	77	50.7	60.0	110	68	3400
R3622.050	50	88	56	66.0	123	75	4400
R3622.060	60	100	66.8	80.0	140	90	7100
R3622.070	70	115	77.8	92.0	164	105	10500
R3622.080	80	141	89.4	105	180	120	15000
R3622.090	90	150	98.1	115	226	130	23500
R3622.100	100	170	109.5	130	250	150	31500
R3622.110	110	185	121.2	140	295	160	48500
R3622.120	120	210	135.5	160	360	180	79000

Order No.	Dyn. load C kN max.	l ₂	l ₃	Static load C ₀ kN max.	w ₁	w ₂	a °
R3622.020	30.00	63.0	2	67.00	19	16	9
R3622.025	48.00	72.5	2	69.50	23	20	7
R3622.030	62.00	83.5	2	118.00	28	22	6
R3622.035	80.00	102.5	2	196.00	30	25	6
R3622.040	100.00	119	3	300.00	35	28	7
R3622.045	127.00	132	3	380.00	40	32	7
R3622.050	156.00	149.5	3	440.00	40	35	6
R3622.060	245.00	170	4	570.00	50	44	6
R3622.070	315.00	197	4	695.00	55	49	6
R3622.080	400.00	231	4	780.00	60	55	6
R3622.090	490.00	263	4	1340.00	65	60	5
R3622.100	610.00	295	4	1500.00	70	70	7
R3622.110	655.00	332.5	4	2160.00	80	70	6



Hydraulic Rod Ends

weld-on base

Rod Ends

Order No.	Dyn. load C kN max.	l_2	l_3	Static load C_0 kN max.	w_1	w_2	a
R3622.120	950.00	390	4	3250.00	90	85	6

ROD ENDS

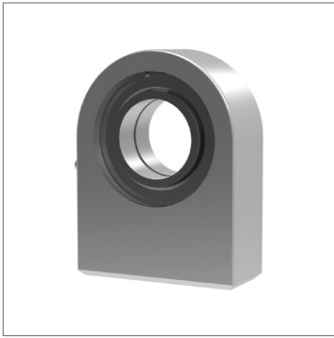

R3623

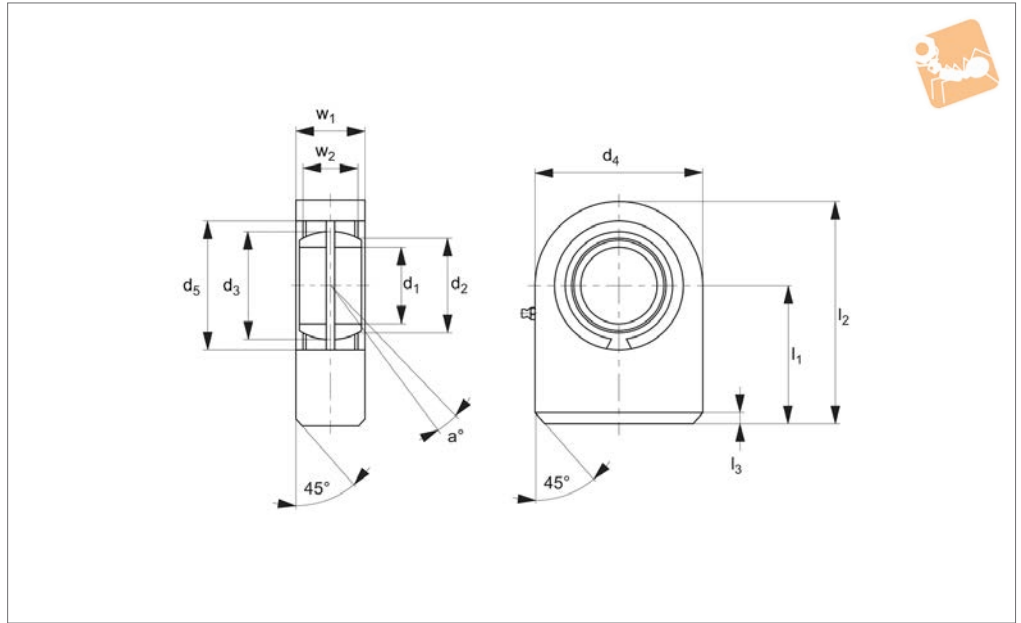

Material

Housing: stainless steel (AISI 316).
Bearing: stainless steel (AISI 420C) and

PTFE fabric.

Order No.	d ₁ tol. M7	l ₁	d ₂	d ₃	d ₄	d ₅	Weight g
R3623.020	20	38	24.1	29.0	50	35	325
R3623.025	25	45	29.3	35.5	55	42	500
R3623.030	30	51	34.2	40.7	65	47	825
R3623.035	35	61	39.7	47.0	83	55	1475
R3623.040	40	69	45	53.0	100	62	2480
R3623.045	45	77	50.7	60.0	110	68	3450
R3623.050	50	88	56	66.0	123	75	4450

Order No.	Dyn. load C kN max.	l ₂	l ₃	Static load C ₀ kN max.	w ₁	w ₂	a °
R3623.020	30.00	63.0	2	67.00	19	16	9
R3623.025	48.00	72.5	2	69.50	23	20	7
R3623.030	62.00	83.5	2	118.00	28	22	6
R3623.035	80.00	102.5	2	196.00	30	25	6
R3623.040	100.00	119	3	300.00	35	28	7
R3623.045	127.00	132	3	380.00	40	32	7
R3623.050	156.00	149.5	3	440.00	40	35	6



Hydraulic Rod Ends with female thread

Rod Ends

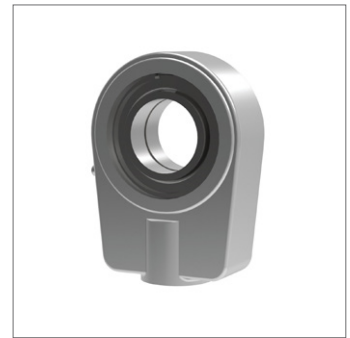
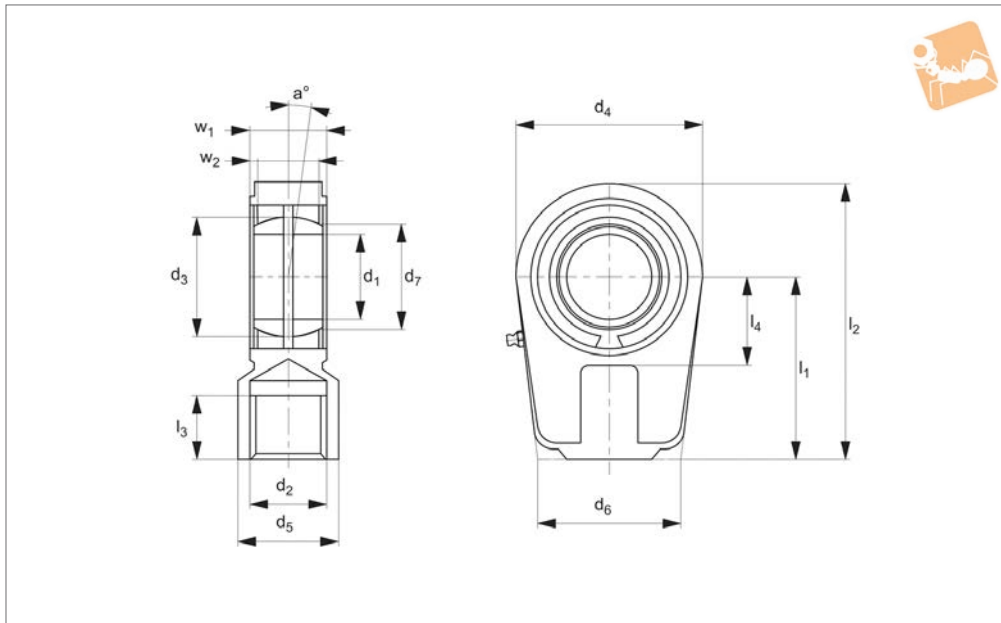

R3624

ROD ENDS

Material

Housing: Up to size 60 - Heat-treated steel (C45).
From size 70 cast iron (GS400).
Steel on steel bearing requiring lubrication, spherical plain bearing.

Technical Notes

Fitted with hydraulic grease nipples to DIN71412, rod ends with short thread, particularly suited to hydraulic cylinders. Spherical plain bearing fixed with snap rings.

Tips

For use with shortest relay distances and maximum stroke utilization.

Order No.	d ₁ tol. M7	l ₁	d ₂ tol. 6H	d ₃	d ₄	d ₅	d ₆	d ₇	Dyn. load C kN max.	Weight g
R3624.020	20	50	M16x1,5	29	56	25	46	24.2	30.00	430
R3624.025	25	50	M16x1,5	35.5	56	25	46	29.3	48.00	480
R3624.030	30	60	M22x1,5	40.7	64	32	50	34.2	62.00	740
R3624.035	35	70	M28x1,5	47	78	40	66	39.8	80.00	1200
R3624.040	40	85	M35x1,5	53	94	49	76	45	100.00	2000
R3624.050	50	105	M45x1,5	66	116	61	90	55.9	156.00	3800
R3624.060	60	130	M58x1,5	80	130	75	120	66.8	245.00	5400
R3624.070	70	150	M65x1,5	92	154	86	130	77.9	245.00	5400
R3624.080	80	170	M80x2,0	105	176	105	160	89.4	400.00	12000
R3624.090	90	210	M100x2,0	115	206	124	180	98.1	490.00	21500
R3624.100	100	235	M110x2,0	130	230	138	200	109.5	610.00	27500
R3624.110	110	265	M120x3,0	140	265	152	220	121.2	655.00	40500
R3624.120	120	310	M130x3,0	160	340	172	257	135.5	950.00	76000

Order No.	l ₂	l ₃	l ₄	Static load C ₀ kN max.	w ₁	w ₂	a °
R3624.020	80	17	25	72.00	19	16	9
R3624.025	80	17	28	72.00	23	20	7
R3624.030	94	23	30	106.00	28	22	6
R3624.035	112	29	38	153.00	30	25	6
R3624.040	135	36	45	250.00	35	28	7
R3624.050	168	46	55	365.00	40	35	6
R3624.060	200	59	65	400.00	50	44	6
R3624.070	237	66	75	400.00	55	49	6
R3624.080	265	81	80	670.00	60	55	6
R3624.090	323	101	90	980.00	65	60	5
R3624.100	360	111	105	1120.00	70	70	7
R3624.110	407.5	125	115	1700.00	80	80	6
R3624.120	490	135	140	2900.00	90	90	6

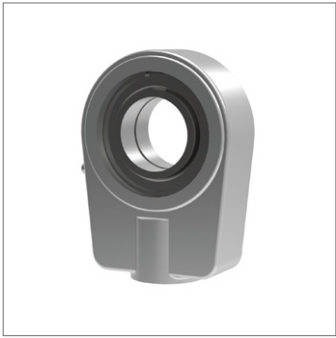

R3625

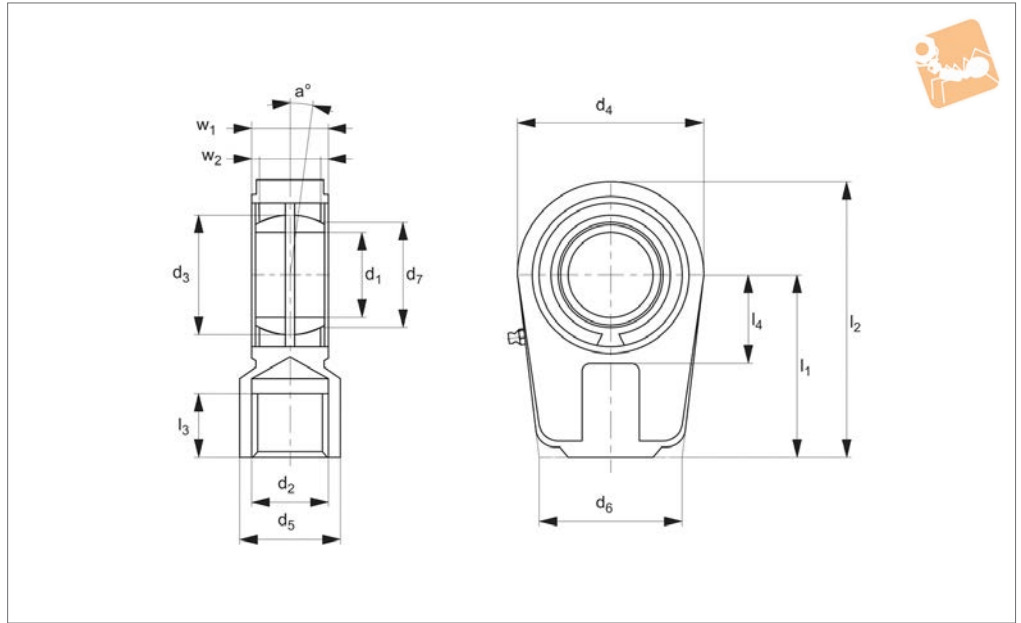

Material

Housing: stainless steel (AISI 316.)
Bearing stainless steel (AISI 420C) and

PTFE fabric.

Tips

Standard thread is right hand thread.

Order No.	d_1 tol. M7	l_1	d_2 tol. 6H	d_3	d_4	d_5	d_6	d_7	Dyn. load C kN max.	Weight g
R3625.020	20	50	M16x1,5	29	56	25	46	24.1	30.00	400
R3625.025	25	50	M16x1,5	35.5	56	25	46	29.3	48.00	475
R3625.030	30	60	M22x1,5	40.7	64	32	50	34.2	62.00	700
R3625.035	35	70	M28x1,5	47	78	40	66	39.7	80.00	1150
R3625.040	40	85	M35x1,5	53	94	49	76	45	100.00	2075
R3625.050	50	105	M45x1,5	66	116	61	90	56	156.00	3575

Order No.	l_2	l_3	l_4	Static load C_0 kN max.	w_1	w_2	a°
R3625.020	80	17	25	72.00	19	16	9
R3625.025	80	17	28	72.00	23	20	7
R3625.030	94	23	30	106.00	28	22	6
R3625.035	112	29	38	153.00	30	25	6
R3625.040	135	36	45	250.00	35	28	7
R3625.050	168	46	55	365.00	40	35	6



Hydraulic Rod Ends with female thread and locking nuts

Rod Ends

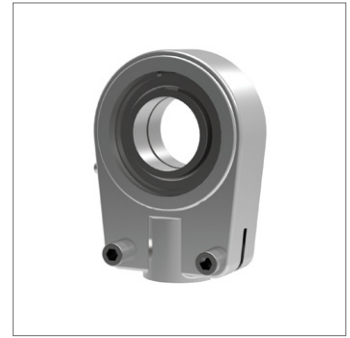

R3626

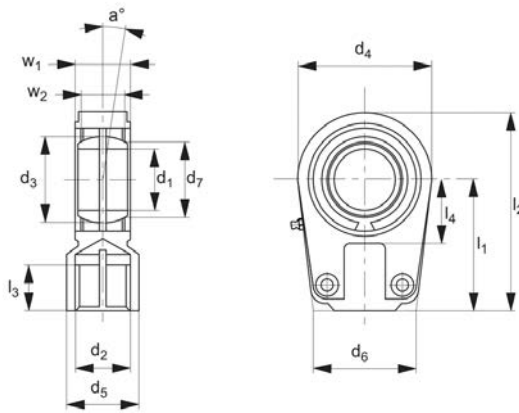

Material

Housing: Up to size 60 - Heat-treated steel (C45).
From size 70 cast iron (GS400).
Steel on steel bearing requiring lubrication.

Spherical plain bearing.

Technical Notes

Fitted with hydraulic grease nipples to DIN71412.
Hex socket cap screw to DIN912-12.9,

spherical plain bearings fixed with snap rings.

Tips

For use with shortest relay distances and maximum stroke utilization.

Order No.	d ₁ tol. M7	l ₁	d ₂ tol. 6H	d ₃	d ₄	d ₅	d ₆	d ₇	Dyn. load C kN max.	Weight g
R3626.020	20	50	M16x1,5	29	56	25	46	24.2	30.00	430
R3626.025	25	50	M16x1,5	35.5	56	25	46	29.3	48.00	480
R3626.030	30	60	M22x1,5	40.7	64	32	50	34.2	62.00	740
R3626.035	35	70	M28x1,5	47	78	40	66	39.8	80.00	1200
R3626.040	40	85	M35x1,5	53	94	49	76	45	100.00	2000
R3626.050	50	105	M45x1,5	66	116	61	90	55.9	156.00	3800
R3626.060	60	130	M58x1,5	80	130	75	120	66.8	245.00	5400
R3626.070	70	150	M65x1,5	92	154	86	130	77.9	245.00	8500
R3626.080	80	170	M80x2,0	105	176	105	160	89.4	400.00	12000
R3626.090	90	210	M100x2,0	115	206	124	180	98.1	490.00	21500
R3626.100	100	235	M110x2,0	130	230	138	200	109.5	610.00	27500
R3626.110	110	265	M120x3,0	140	265	152	220	121.2	655.00	40500
R3626.120	120	310	M130x3,0	160	340	172	257	135.5	950.00	76000

Order No.	l ₂	l ₃	l ₄	Static load C ₀ kN max.	w ₁	w ₂	a °
R3626.020	80	17	25	72.00	19	16	9
R3626.025	80	17	28	72.00	23	20	7
R3626.030	94	23	30	106.00	28	22	6
R3626.035	112	29	38	153.00	30	25	6
R3626.040	135	36	45	250.00	35	28	7
R3626.050	168	46	55	365.00	40	35	6
R3626.060	200	59	65	400.00	50	44	6
R3626.070	237	66	75	400.00	55	49	6
R3626.080	265	81	80	670.00	60	55	6
R3626.090	323	101	90	980.00	65	60	5
R3626.100	360	111	105	1120.00	70	70	7
R3626.110	407.5	125	115	1700.00	80	80	6
R3626.120	490	135	140	2900.00	90	90	6

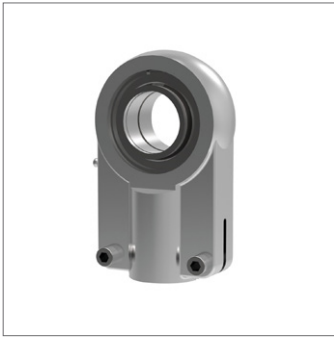

R3628

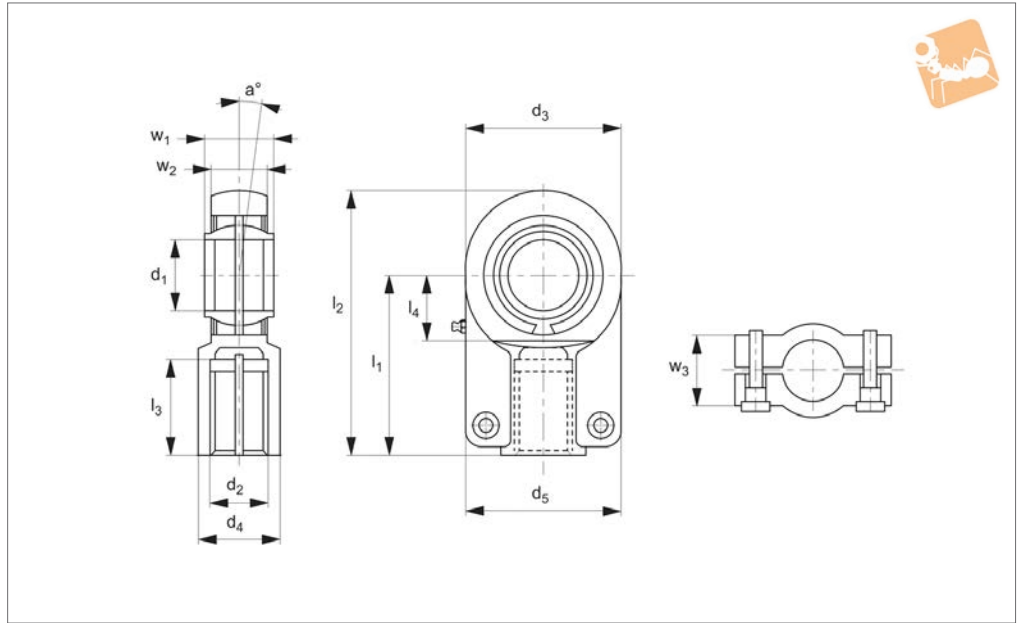

Material

Housing: Up to size 60 - Heat-treated steel (C45).

From size 70 cast iron (GS400).

Bearing: steel on steel requiring lubrication.

For standard hydraulic cylinders, fastened by hexagon socket cap screws to DIN912-12.9.

Spherical plain bearings, regreasable, fixed with snap rings, sizes up to 12 not regreasable.

hand thread available on request.

Technical Notes

DIN24338/ISO6982.

Tips

Standard thread is right hand thread, left

Order No.	d ₁ tol. H7	l ₁	d ₂ tol. 6H	d ₃	d ₄	d ₅	Dyn. load C kN max.	l ₂	l ₃	Weight g
R3628.012	12	38	M12x1,25	32	16.5	32	10.80	54	17	100
R3628.016	16	44	M14x1,5	40	21	40	17.60	64	19	200
R3628.020	20	52	M16x1,5	47	25	47	30.00	77	23	400
R3628.025	25	65	M20x1,5	58	30	54	48.00	96	29	660
R3628.032	32	80	M27x2,0	71	38	66	67.00	118.5	37	1200
R3628.040	40	97	M33x2,0	90	47	80	100.00	146	46	2100
R3628.050	50	120	M42x2,0	109	58	96	156.00	179.5	57	4400
R3628.063	63	140	M48x2,0	136	70	114	255.00	213	64	7600
R3628.070	70	160	M56x2,0	155	80	135	315.00	245	76	9500
R3628.080	80	180	M64x3,0	168	90	148	400.00	270	86	14500
R3628.090	90	195	M72x3,0	185	100	160	490.00	296	91	17000
R3628.100	100	210	M80x3,0	210	110	178	610.00	322	96	28000
R3628.110	110	235	M90x3,0	235	125	190	655.00	364	106	32000
R3628.125	125	102	M100x3,0	260	135	200	950.00	405	113	43000

Order No.	l ₄	Static load C ₀ kN max.	w ₁	w ₂	w ₃	a°
R3628.012	14	17.60	12	11	11	4
R3628.016	18	36.50	16	14	14	4
R3628.020	22	48.00	20	17	17	4
R3628.025	27	78.00	25	22	19	4
R3628.032	32	114.00	32	28	22	4
R3628.040	41	204.00	40	33	26	4
R3628.050	50	310.00	50	41	32	4
R3628.063	62	430.00	63	53	38	4
R3628.070	70	540.00	70	57	42	4
R3628.080	78	695.00	80	66	48	4



Hydraulic Rod Ends with female thread and locking nuts

Rod Ends

Order No.	l_4	Static load C_0 kN max.	w_1	w_2	w_3	a °
R3628.090	85	750.00	90	72	52	4
R3628.100	98	1060.00	100	84	62	4
R3628.110	105	1200.00	110	88	62	4
R3628.125	120	1430.00	125	102	72	4

ROD ENDS

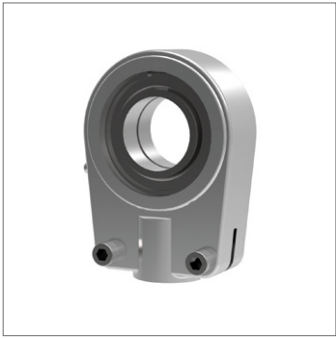

R3627

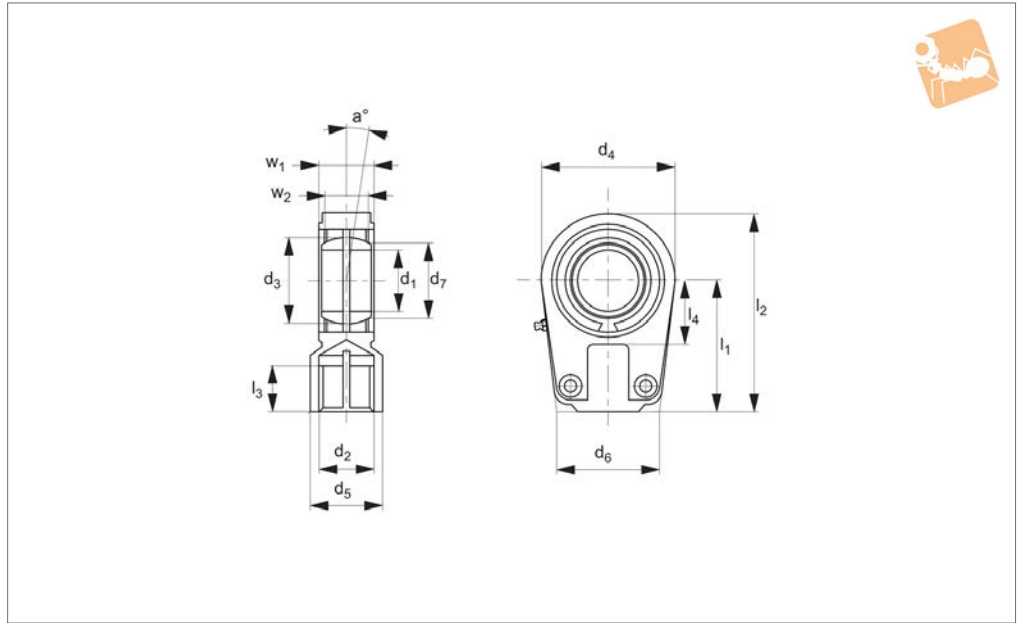

Material

Housing: stainless steel (AISI 316).
Bearing stainless steel (AISI 420C) and PTFE fabric.

Technical Notes

Hex socket cap screw to DIN912-12.9.
Spherical plain bearings fixed with snap rings, maintenance free.

Tips

Standard thread is right hand thread.

Order No.	d ₁ tol. M7	l ₁	d ₂ tol. 6H	d ₃	d ₄	d ₅	d ₆	d ₇	Dyn. load C kN max.	Weight g
R3627.020	20	50	M16x1,5	29	56	25	46	24.1	30.00	400
R3627.025	25	50	M16x1,5	35.5	56	25	46	29.3	48.00	475
R3627.030	30	60	M22x1,5	40.7	64	32	50	34.2	62.00	700
R3627.035	35	70	M28x1,5	47	78	40	66	39.7	80.00	1150
R3627.040	40	85	M35x1,5	53	94	49	76	45	100.00	2075
R3627.050	50	105	M45x1,5	66	116	61	90	56	156.00	3575

Order No.	l ₂	l ₃	l ₄	Static load C ₀ kN max.	w ₁	w ₂	a °
R3627.020	80	17	25	72.00	19	16	9
R3627.025	80	17	28	72.00	23	20	7
R3627.030	94	23	30	106.00	28	22	6
R3627.035	112	29	38	153.00	30	25	6
R3627.040	135	36	45	250.00	35	28	7
R3627.050	168	46	55	365.00	40	35	6

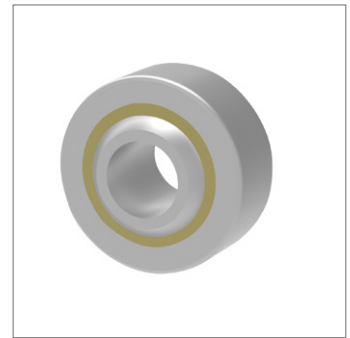
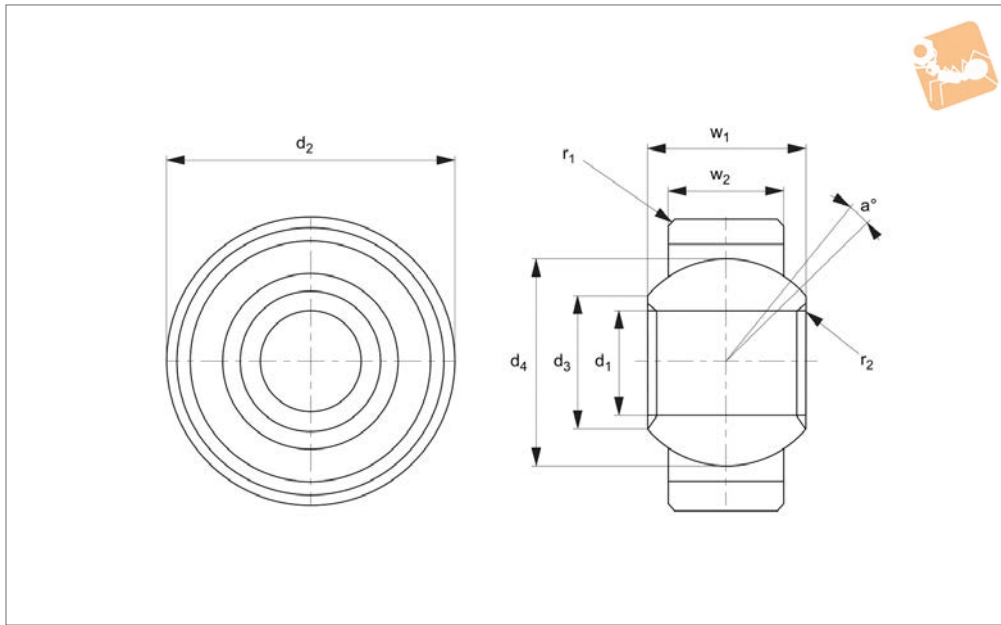

R3640

ROD ENDS

Material

Housing: undercut steel 11SMnPb30K (1.0718) turned silver zinc plated.
Ball: ball bearing steel 100Cr6 hardened, surface condition polished.

Race: teflon.

Technical Notes
To DIN 12240-1

Tips

For stainless steel version see R3641

Order No.	a °	d ₁ tol. H7	d ₂	d ₃	d ₄	r ₁	r ₂	w ₁	w ₂	Static load C ₀ kN max.	Weight g
R3640.005	13	5	16	7.7	11.10	0.3	1.2	8	6	17	9
R3640.006	13	6	18	8.9	12.70	0.3	1.2	9	6.75	22	13
R3640.008	13	8	22	10.3	15.88	0.3	1.2	12	9	36	24
R3640.010	13	10	26	12.9	19.05	0.3	1.2	14	10.5	50	40
R3640.012	13	12	30	15.4	22.23	0.4	1.2	16	12	67	80
R3640.016	15	16	38	19.3	28.58	0.4	1.5	21	15	107	130

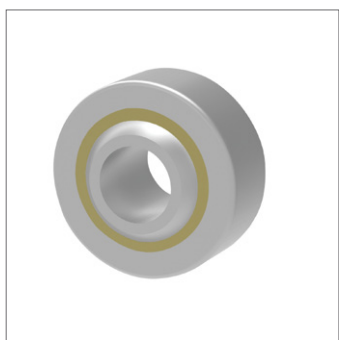

R3640.i

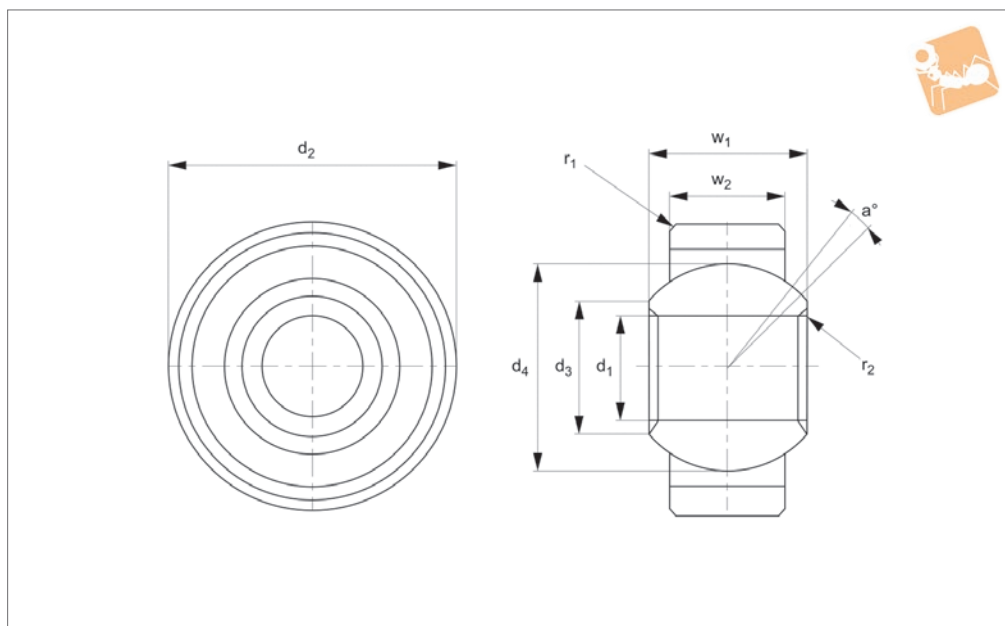

Material

Zinc - plated steel, Teflon or PTFE bearing race.

Order No.	α	d_1	d_2	d_3	d_4	r_1	w_1	w_2	Radial static load kN max.	Weight g
R3640.0190	11,0°	0.1900	0.5625	0.293	0.406	0.015	0.281	0.218	21.6	5
R3640.0250	13,5°	0.2500	0.6562	0.364	0.5	0.022	0.343	0.25	33.0	9
R3640.0313	12,0°	0.3125	0.75	0.419	0.562	0.032	0.375	0.281	43.2	14
R3640.0375	10,0°	0.3750	0.8125	0.516	0.656	0.032	0.406	0.312	56.0	18
R3640.0438	8,0°	0.4375	0.9062	0.53	0.687	0.032	0.437	0.343	63.0	22
R3640.0500	9,5°	0.5000	1	0.64	0.813	0.032	0.5	0.39	88.4	31
R3640.0563	9,5°	0.5625	1.0937	0.71	0.906	0.032	0.562	0.437	110.9	40
R3640.0625	8,5°	0.6250	1.1875	0.78	1	0.032	0.625	0.5	141.9	49
R3640.0750	9,0°	0.7500	1.4375	0.92	1.187	0.044	0.75	0.593	213.0	90
R3640.0875	9,5°	0.8750	1.5265	0.98	1.312	0.044	0.875	0.703	279.9	118
R3640.1000	10,0°	1.0000	1.75	1.118	1.5	0.044	1	0.797	368.3	177

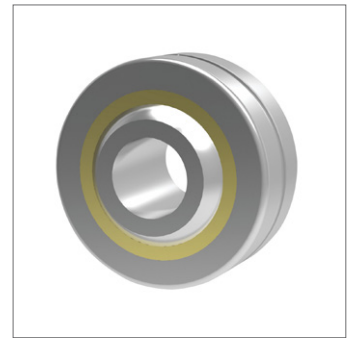
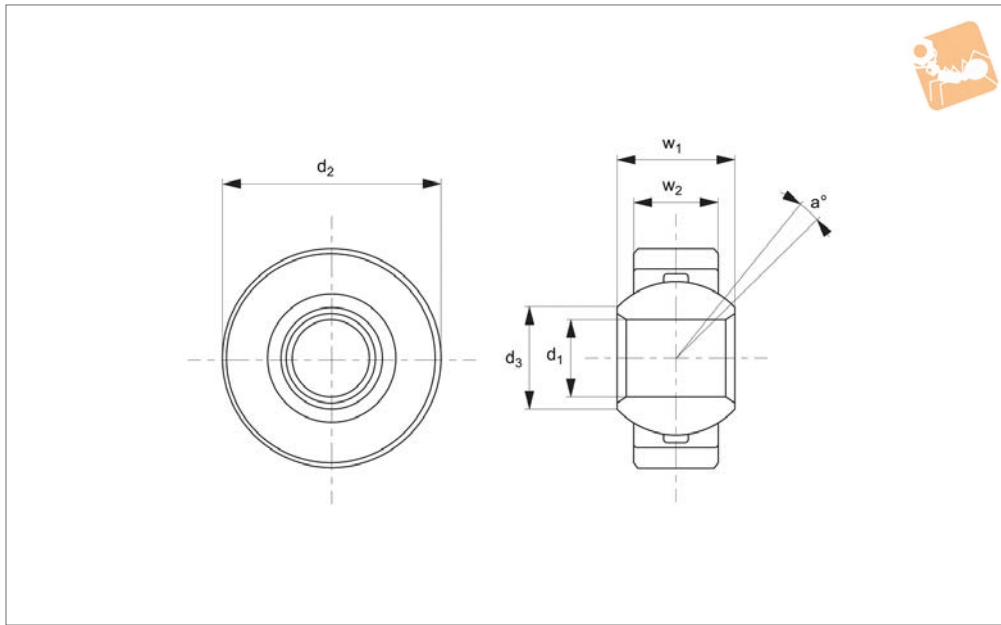

R3642

ROD ENDS

Material

Housing: stainless steel (1.4305) turned.
 Bearing shell: special brass CuSn8 surface coated with a PTFE foil.
 Ball: ball bearing steel 100Cr6 hardened, surface condition polished, hard chrome plated.
 Upon request: stainless steel (1.4034) hardened, surface condition polished.

Stainless steel (1.4401) not hardened, surface condition polished.

Technical Notes

Suitable for low speeds and high dynamic loads.

Maintenance free, series K similar to DIN 12240-1 (DIN 648)

Important Notes

Working range -50°C to +200°C
 Recommended shaft tolerance: g6

External diameter of pivoting bearing: h6

Recommended housing tolerance: J7

Order No.	a °	d ₁ tol. H7	d ₂	d ₃	w ₁	w ₂	Admissible rpm min.	Static load C ₀ kN max.	Weight g
R3642.005	13	5	16	7.7	8	6	600	12.5	8
R3642.006	13	6	18	8.9	9	6.75	530	15.5	12
R3642.008	14	8	22	10.4	12	9	420	27.8	23
R3642.010	13	10	26	12.9	14	10.5	350	39	38
R3642.012	13	12	30	15.4	16	12	300	53.5	58
R3642.016	15	16	38	19.3	21	15	230	88	115



R3630

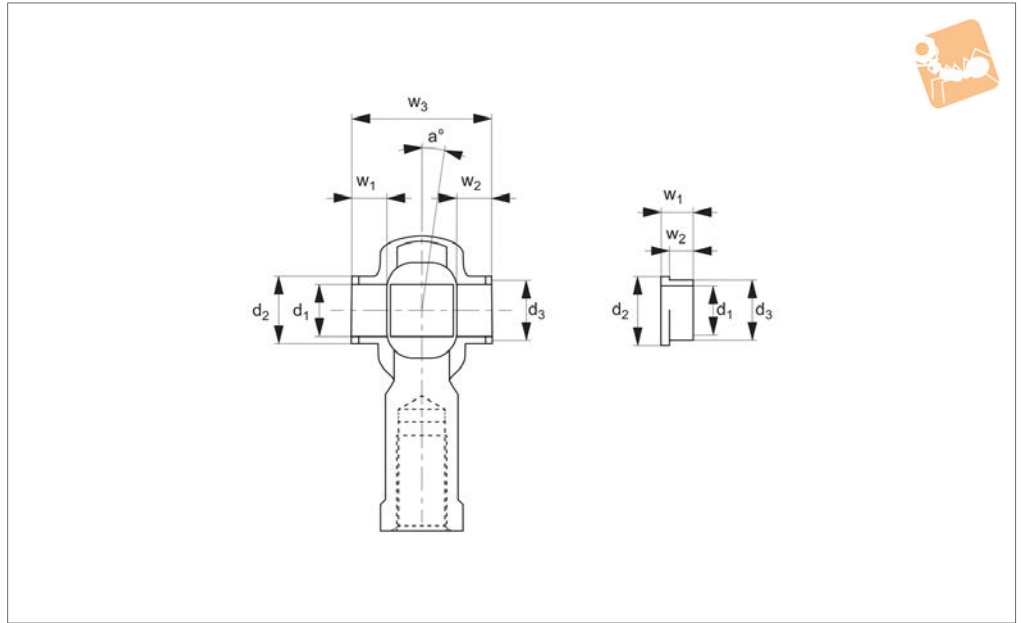

Material
Rubber

protection of rod ends. For use with main-
tenance free series K rod ends.
Brass spacer bush available on request.
Temperature range: -20°C to + 110°C.

Tips
Mounted easily with retaining pliers.

Technical Notes

Rubber protector caps for additional

Order No.	Suitable for steel rod ends	Suitable for stainless steel rod ends	d ₁	d ₂	d ₃	w ₁	w ₂	w ₃	a _°	Weight g
R3630.006	R3550/R3551.006	R3565/R3566.006	6	11	8.7	6	4	21	13	3
R3630.008	R3550/R3551.008	R3565/R3566.008	8	12	10.3	6	4	24	14	3
R3630.010	R3550/R3551.010	R3565/R3566.010	10	14	12.5	6	4	26	14	5
R3630.012	R3550/R3551.012	R3565/R3566.012	12	17	15.0	8	6	32	13	5
R3630.014	R3550/R3551.014	R3565/R3566.014	14	19	16.8	8	6	35	16	7
R3630.016	R3550/R3551.016	R3565/R3566.016	16	21	19.0	8	6	37	15	7
R3630.018	R3550/R3551.018	R3565/R3566.018	18	25	21.8	8	6	39	15	7
R3630.020	R3550/R3551.020	R3565/R3566.020	20	28	24.3	10	8	45	15	40
R3630.022	R3550/R3551.022	R3565/R3566.022	22	29	25.7	10	8	48	15	40
R3630.025	R3550/R3551.025	R3565/R3566.025	25	33	29.7	10	8	51	15	40

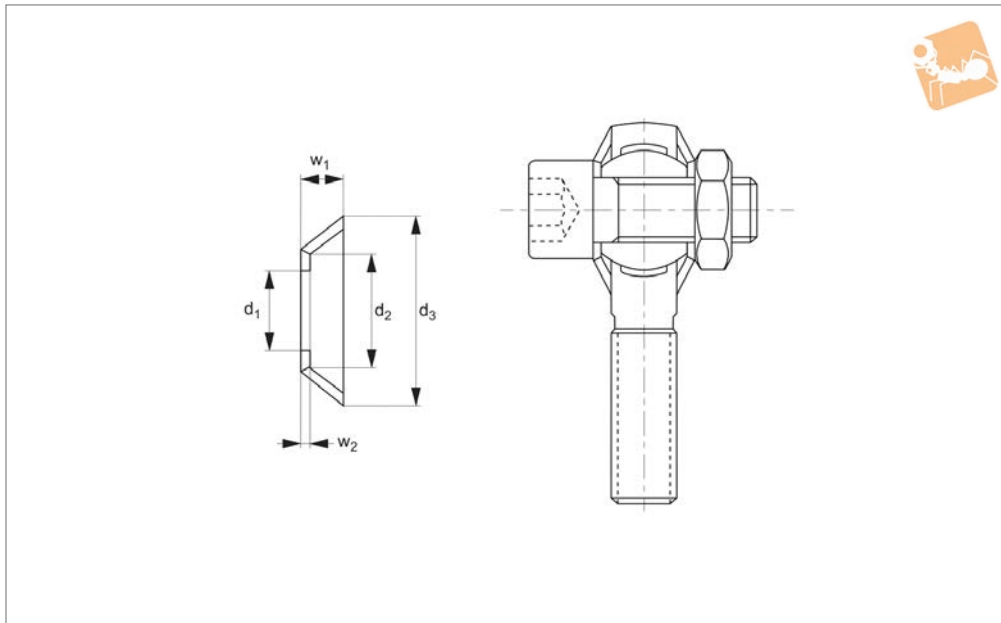

R3631

ROD ENDS

Material

Seal: neoprene rubber.
Washer: stainless steel.

bearing for use with series K rod ends.
Consisting of grease, oil, saltwater, as well as several chemicals.
Temperature range -20°C to +110°C

Tips

Before installation, fill cup half full with waterpump grease.

Technical Notes

Washers for additional protection of

Order No.	Suitable for rod end bore size	d ₁ ±0.13	d ₂ ±0.13	d ₃ ±0.25	w ₁ ±0.25	w ₂ ±0.13	Weight g
R3631.005	5	5.25	8.28	11.22	2.41	0.50	1
R3631.006	6	6.25	9.53	12.7	3.05	0.69	1
R3631.008	8	8.25	12.37	17.78	5.08	1.20	2
R3631.010	10	10.25	13.46	20.32	5.59	1.20	2
R3631.012	12	12.25	18.54	28.58	6.35	1.20	3
R3631.014	14	14.25	20.32	29.21	6.86	1.20	3
R3631.016	16	16.25	22.4	31.7	6.8	1.20	4
R3631.018	18	18.25	22.6	32.69	8.25	1.20	5
R3631.020	20	20.25	25.15	38.1	10.16	1.20	6
R3631.025	25	25.25	33.8	53.3	12.7	1.50	9
R3631.030	30	30.25	35.56	55.88	19.97	1.53	11



R3670

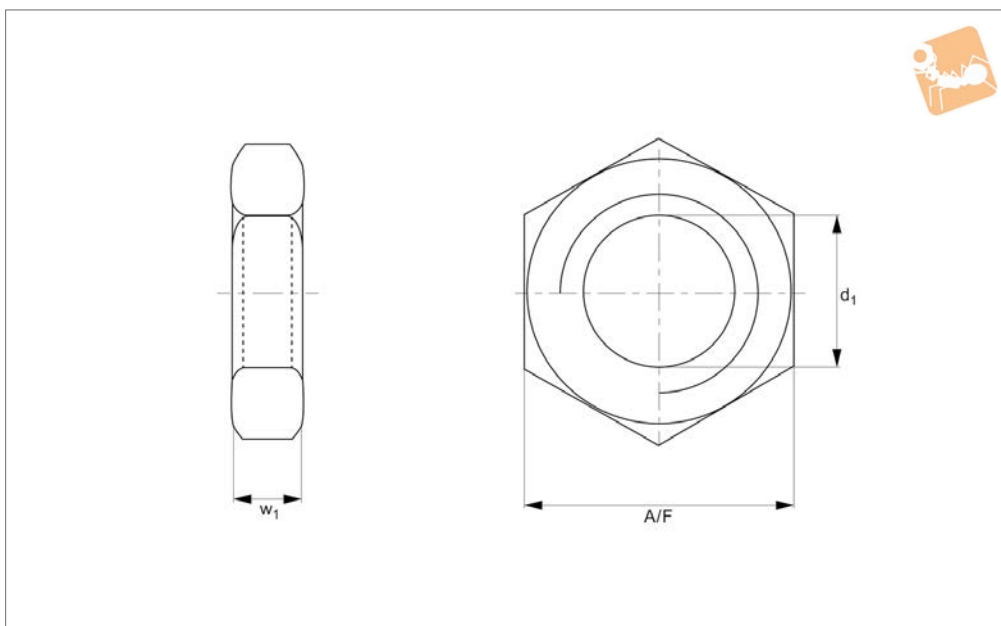

Material

Mild steel, silver zinc plated

Technical Notes

Hexagonal lock nuts to DIN 936

Order No.	Thread hand	d	A/F	w	Weight g
R3670.R005	Right	M5	8	2.7	2
R3670.R006	Right	M6	10	3.2	3
R3670.R008	Right	M8	13	5	4
R3670.R010	Right	M10	17	6	8
R3670.R011	Right	M10x1,25	17	6	8
R3670.R012	Right	M12	19	7	10
R3670.R013	Right	M12x1,25	19	7	10
R3670.R014	Right	M14	22	8	16
R3670.R015	Right	M14x1,5	22	8	16
R3670.R016	Right	M16	24	8	18
R3670.R017	Right	M16x1,5	24	8	18
R3670.R018	Right	M18x1,5	27	9	28
R3670.R020	Right	M20x1,5	30	9	32
R3670.R022	Right	M22x1,5	32	10	40
R3670.R024	Right	M24x2	36	10	52
R3670.R027	Right	M27x2	41	12	102
R3670.R030	Right	M30x2	46	12	102
R3670.R036	Right	M36x3	55	18	175
R3670.R039	Right	M39x3	60	16	240
R3670.R042	Right	M42x3	65	16	290
R3670.R045	Right	M45x3	70	18	380
R3670.R052	Right	M52x3	80	26	535
R3670.R060	Right	M60x4	90	27	860
R3670.L005	Left	M5	8	2.7	2
R3670.L006	Left	M6	10	3.2	3
R3670.L008	Left	M8	13	5	4
R3670.L010	Left	M10	17	6	8
R3670.L011	Left	M10x1,25	17	6	8
R3670.L012	Left	M12	19	7	10
R3670.L013	Left	M12x1,25	19	7	10
R3670.L014	Left	M14	22	8	16
R3670.L015	Left	M14x1,5	22	8	16
R3670.L016	Left	M16	24	8	18
R3670.L017	Left	M16x1,5	24	8	18



Steel Lock Nuts

Rod Ends

Order No.	Thread hand	d	A/F	w	Weight g
R3670.L018	Left	M18x1,5	27	9	28
R3670.L020	Left	M20x1,5	30	9	32
R3670.L022	Left	M22x1,5	32	10	40
R3670.L024	Left	M24x2	36	10	52
R3670.L027	Left	M27x2	41	12	102
R3670.L030	Left	M30x2	46	12	102
R3670.L036	Left	M36x3	55	18	175
R3670.L039	Left	M39x3	60	16	240
R3670.L042	Left	M42x3	65	16	290
R3670.L045	Left	M45x3	70	18	380
R3670.L052	Left	M52x3	80	26	535
R3670.L060	Left	M60x4	90	27	860

ROD ENDS

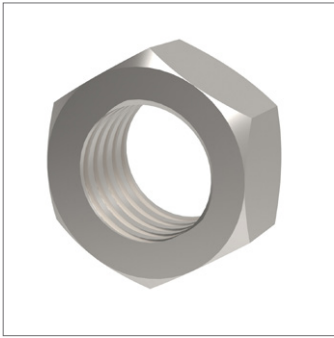

R3671

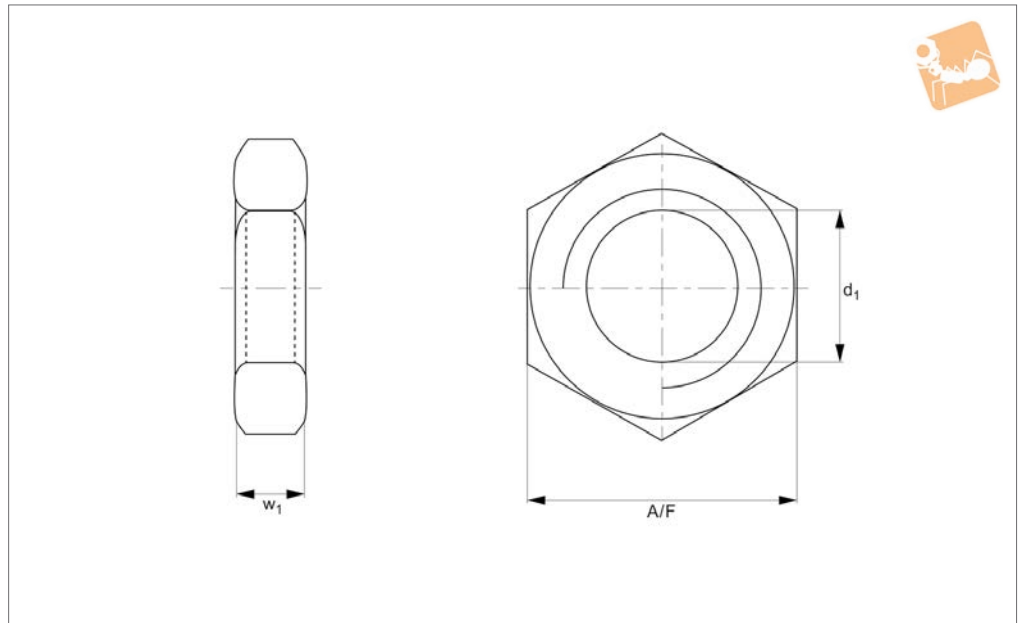

Material
Stainless steel (A2)

8675 (DIN 439/936)

Technical Notes
Hexagonal lock nuts similar to ISO 4035/

Tips
Stainless steel (A4) available on request.

Order No.	Thread hand	d	A/F	w	Weight g
R3671.R005	Right	M5	8	2.7	2
R3671.R006	Right	M6	10	3.2	3
R3671.R008	Right	M8	13	4	4
R3671.R009	Right	M8x1,0	13	4	4
R3671.R010	Right	M10	17	5	8
R3671.R011	Right	M10x1,25	17	6	8
R3671.R012	Right	M12	19	6	10
R3671.R013	Right	M12x1,25	19	6	10
R3671.R014	Right	M14	22	7	18
R3671.R015	Right	M14x1,5	22	7	18
R3671.R016	Right	M16	24	8	20
R3671.R017	Right	M16x1,5	24	8	20
R3671.R018	Right	M18	27	9	30
R3671.R019	Right	M18x1,5	27	9	30
R3671.R020	Right	M20	30	10	32
R3671.R021	Right	M20x1,5	30	10	32
R3671.R022	Right	M22	34	11	40
R3671.R023	Right	M22x1,5	34	11	40
R3671.R024	Right	M24	36	12	52
R3671.R025	Right	M24x2,0	36	12	52
R3671.R027	Right	M27	41	13.5	90
R3671.R028	Right	M27x2,0	41	13.5	90
R3671.R030	Right	M30	46	15	110
R3671.R031	Right	M30x2,0	46	15	110
R3671.R033	Right	M33	50	16.5	155
R3671.R036	Right	M36	55	18	190
R3671.L006	Left	M6	10	4	3
R3671.L008	Left	M8	13	5	4
R3671.L010	Left	M10	17	6	8
R3671.L012	Left	M12	19	7	10
R3671.L016	Left	M16	24	8	20
R3671.L020	Left	M20	30	9	32



Stainless Lock Nuts

Rod Ends

Order No.	Thread hand	d	A/F	w	Weight g
R3671.L022	Left	M24	32	10	40
R3671.L030	Left	M30	46	15	110
R3671.L036	Left	M36	55	18	190

ROD ENDS