

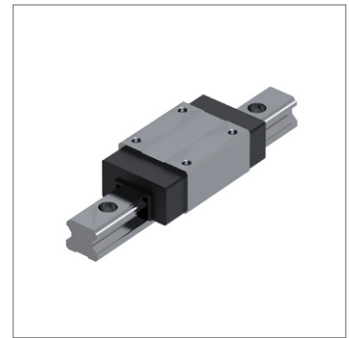

Unflanged Carriages - Low with retained ball cage

Linear Guide- ways

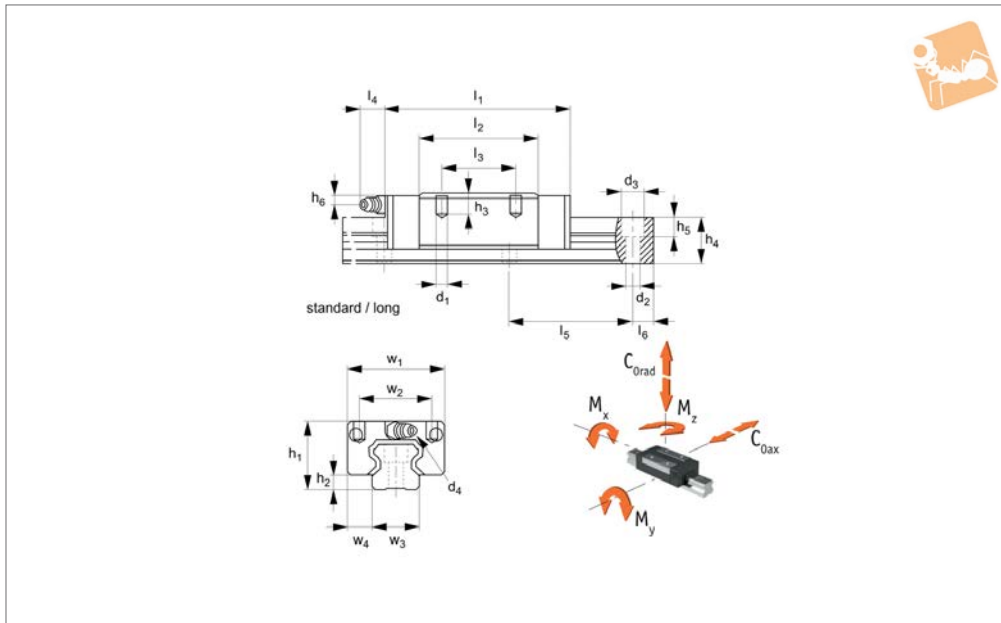

L1016.UL

LINEAR GUIDEWAYS

Material

Hardened and ground steel.

Technical Notes

Select the size and number of carriages to

suit the required load then select the required rail length, (see part nos. L1016.15 through to L1016.55). Standard preload carriages are K_0 (no

preload) or K_1 (0,02 x dynamic load capacity). Other preloads available on request.

Order No.	Rail size	l_1	h_1	l_2	w_1	l_3	h_2	h_3	h_4	d_1	h_5	d_2	h_6	w_2	w_3	w_4	l_4	Weight kg
L1016.UL15-S	15	40.6	24	22.2	34	-	3.3	4.8	13.0	M 4	6.0	4.5	5.5	26	15	9.5	5.0	0.10
L1016.UL15	15	58.6	24	40.2	34	26	3.3	4.8	13.0	M 4	6.0	4.5	5.5	26	15	9.5	5.0	0.17
L1016.UL15-L	15	66.1	24	47.7	34	26	3.0	4.8	13.0	M 4	6.0	4.5	5.5	26	15	9.5	5.0	0.18
L1016.UL20-S	20	48.3	28	27.5	42	-	4.5	5.5	16.3	M 5	8.5	6.0	5.1	32	20	11.0	15.6	0.17
L1016.UL20	20	69.3	28	48.5	42	32	4.5	5.5	16.3	M 5	8.5	6.0	7.1	32	20	11.0	15.6	0.26
L1016.UL25-S	25	54.0	33	32.3	48	-	5.8	6.8	19.2	M 6	9.0	7.0	7.2	35	23	12.5	15.6	0.21
L1016.UL25	25	79.2	33	57.5	48	35	5.8	6.8	19.2	M 6	9.0	7.0	7.2	35	23	12.5	15.6	0.38
L1016.UL30-S	30	64.2	42	37.2	60	-	7.0	10.0	22.8	M 8	12.0	9.0	10.0	40	28	16.0	15.6	0.50
L1016.UL30	30	94.8	42	67.8	60	40	7.0	10.0	22.8	M 8	12.0	9.0	10.0	40	28	16.0	15.6	0.80
L1016.UL30-L	30	105.0	42	78.0	60	40	7.0	10.0	22.8	M 8	12.0	9.0	10.0	40	28	16.0	15.6	0.94
L1016.UL30-XL	30	130.5	42	103.5	60	60	7.0	10.0	22.8	M 8	12.0	9.0	10.0	40	28	16.0	15.6	1.16
L1016.UL35-S	35	75.5	48	44.5	70	-	7.5	10.0	26.0	M 8	12.0	9.0	11.5	50	34	18.0	16.0	0.80
L1016.UL35	35	111.5	48	80.5	70	50	7.5	10.0	26.0	M 8	12.0	9.0	11.5	50	34	18.0	16.0	1.20
L1016.UL35-L	35	123.5	48	92.5	70	50	7.5	10.0	26.0	M 8	12.0	9.0	11.5	50	34	18.0	16.0	1.40
L1016.UL35-XL	35	153.5	48	122.5	70	72	7.5	10.0	26.0	M 8	12.0	9.0	11.5	50	34	18.0	16.0	1.84
L1016.UL45	45	129.0	60	94.0	86	60	8.9	15.5	31.1	M10	17.0	14.0	14.4	60	45	20.5	16.0	1.64
L1016.UL45-L	45	145.0	60	110.0	86	60	8.9	15.5	31.1	M10	17.0	14.0	14.4	60	45	20.5	16.0	1.93
L1016.UL45-XL	45	174.0	60	139.0	86	80	8.9	15.5	31.1	M10	17.0	14.0	14.4	60	45	20.5	16.0	2.42
L1016.UL55	55	155.0	70	116.0	100	75	12.7	18.0	38.0	M12	20.0	16.0	14.0	75	53	23.5	16.0	2.67
L1016.UL55-L	55	193.0	70	154.0	100	75	12.7	18.0	38.0	M12	20.0	16.0	14.0	75	53	23.5	16.0	3.57
L1016.UL55-XL	55	210.0	70	171.0	100	95	12.7	18.0	38.0	M12	20.0	16.0	14.0	75	53	23.5	16.0	3.97

Order No.	l_5	l_6	d_3	d_4	M_x Nm	M_y Nm	M_z Nm	Dyn. load $C_{rad \& ax}$ kN	Static load $C_{Orad \& ax}$ kN
L1016.UL15-S	60	20.0	7.5	M3x0,5	69	32	32	5.81	9.90
L1016.UL15	60	20.0	7.5	M3x0,5	137	120	120	11.67	19.90
L1016.UL15-L	60	20.0	7.5	M3x0,5	166	171	171	14.12	24.05
L1016.UL20-S	60	20.0	9.5	M6x1,0	148	66	66	9.25	15.93
L1016.UL20	60	20.0	9.5	M6x1,0	289	224	224	17.98	30.96
L1016.UL25-S	60	20.0	11.0	M6x1,0	230	103	103	12.87	21.34
L1016.UL25	60	20.0	11.0	M6x1,0	447	358	358	25.25	41.73
L1016.UL30-S	80	20.0	14.0	M6x1,0	356	153	153	18.50	27.51
L1016.UL30	80	20.0	14.0	M6x1,0	719	560	560	37.33	55.50



Order No.	l_5	l_6	d_3	d_4	M_x Nm	M_y Nm	M_z Nm	Dyn. load $C_{rad \& ax}$ kN	Static load $C_{0rad \& ax}$ kN
L1016.UL30-L	80	20.0	14.0	M6x1,0	931	836	836	48.35	71.88
L1016.UL30-XL	80	20.0	14.0	M6x1,0	1142	1361	1361	53.83	88.18
L1016.UL35-S	80	20.0	14.0	M6x1,0	655	275	275	26.72	41.43
L1016.UL35	80	20.0	14.0	M6x1,0	1307	991	991	53.31	82.66
L1016.UL35-L	80	20.0	14.0	M6x1,0	1633	1424	1424	66.61	103.29
L1016.UL35-XL	80	20.0	14.0	M6x1,0	2020	2330	2330	73.29	127.68
L1016.UL45	105	22.5	20.0	M8x1,25	2353	1559	1559	73.14	111.30
L1016.UL45-L	105	22.5	20.0	M8x1,25	2798	2170	2170	86.99	132.39
L1016.UL45-XL	105	22.5	20.0	M8x1,25	3527	3455	3455	100.52	166.87
L1016.UL55	120	30.0	23.0	M8x1,25	3385	2361	2361	88.26	136.62
L1016.UL55-L	120	30.0	23.0	M8x1,25	4538	4202	4202	119.10	183.14
L1016.UL55-XL	120	30.0	23.0	M8x1,25	6430	6617	6617	161.43	259.71



L1016 Linear guideways

Linear guideways are widely used throughout industry for heavy-duty and precise applications.

Precision high load rails

The use of steel balls and the design of the carriages and guideways mean that the rails can accept very heavy loads and significant moment loads. Our rails have circular as opposed to friction coefficient, lower driving resistance, lower wear and lower energy consumption.

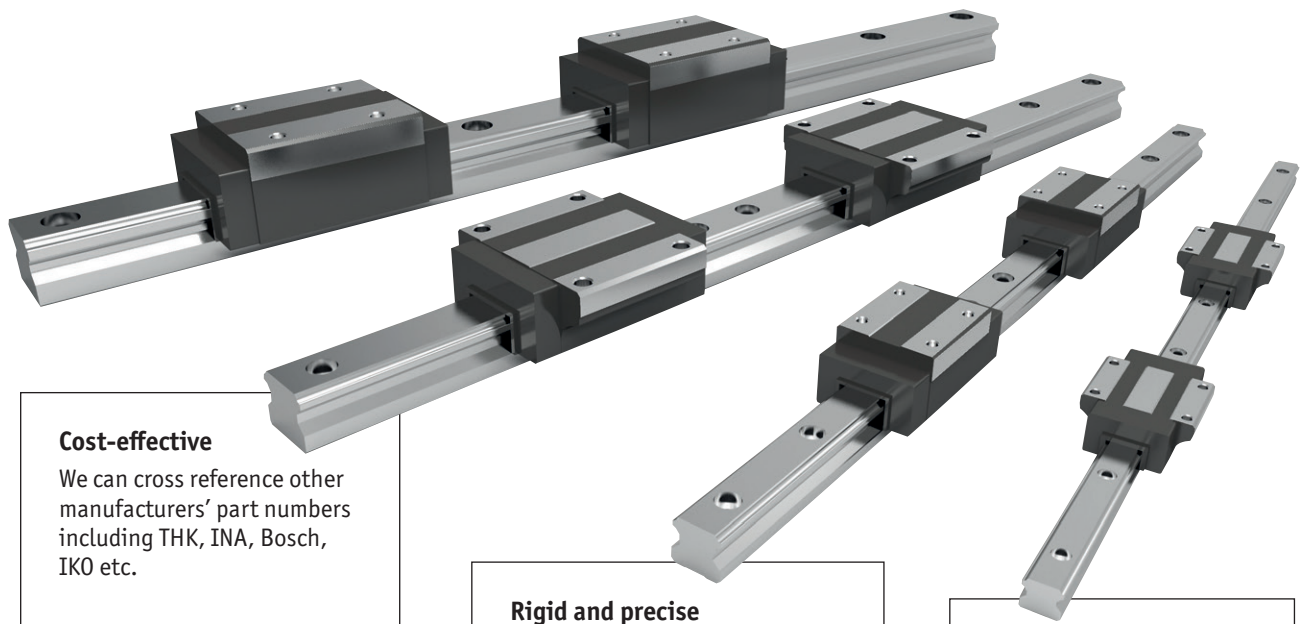

Cost-effective

We can cross reference other manufacturers' part numbers including THK, INA, Bosch, IKO etc.

Rigid and precise

- High load rating.
- High moment load capacity.

Stocked

7 rail profiles ready for same day despatch. Lengths up to 4 metres.

Rail sizes

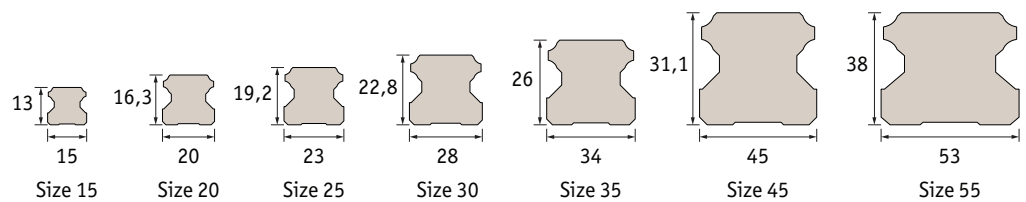



- Carriage types

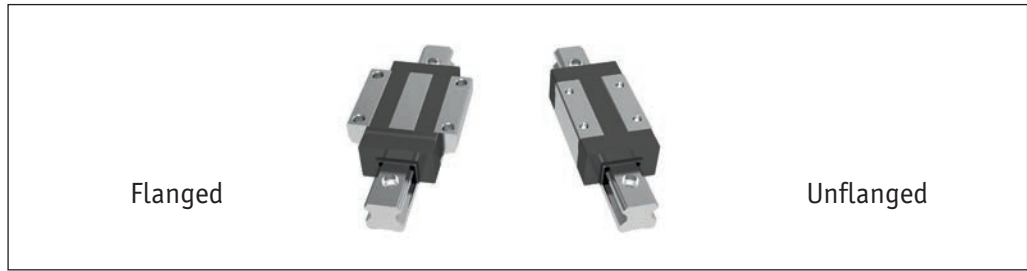

Carriage lengths

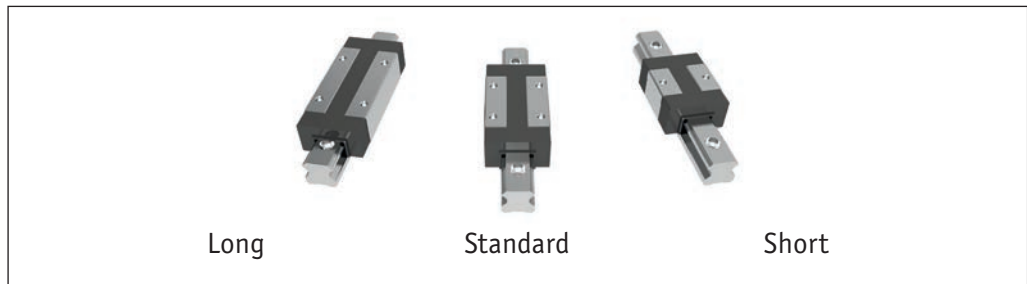

Rail types

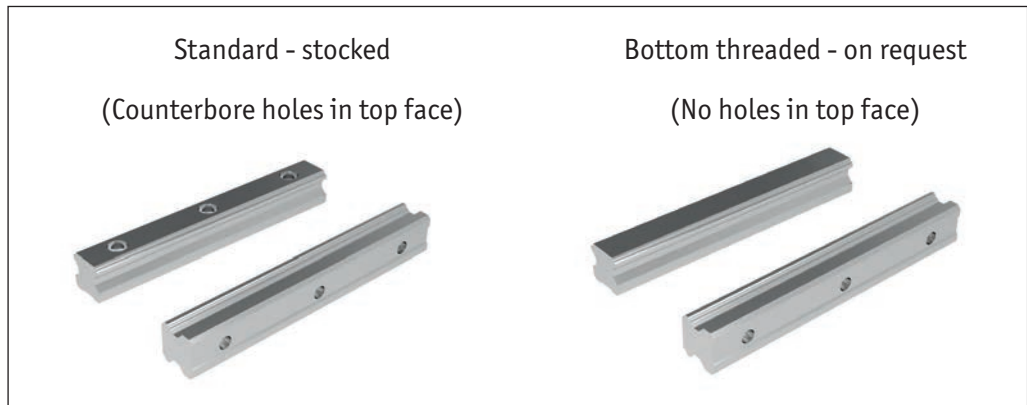

Linear Guideways from Automation Components

CAD - Download in 3 easy steps

Most of our products are available to download directly from our website. Get the CAD you need for your application in minutes, no registration required.

<p>Step 1: find the part you need</p> <p>Find the part or enter the Automation part number into the search bar.</p>	
<p>Step 2: Choose the CAD option</p> <p>Click on the CAD button below the product window to the right of the drawing.</p>	
<p>Step 3: Download your format</p> <p>Choose the the format you require, and download it to your computer.</p>	

Load capacities – explained

- A number of load figures are stated for load capacity:

Dynamic Load – this is the main figure considered for linear guideways. It is the moving load that the system can bear. It takes account of the total moving load as well as considerations such as impact, vibration and fatigue.

Static Load – this is a load that is constant for an extended time (i.e. the dead load the system can bear before any movement). It can be in tension or compression.

For these linear guideways the radial and axial load capacities are the same.

Moment loads are twisting loads generated by offset loads in either X, Y or Z planes. Moment loads can be reduced by adding further carriages or rails to reduce any twisting of the carriage due to the load offset.

Straightness of rails

- The measurements of the straightness of the system are taken from the running accuracy of the sliders over the length of the rails (given in microns) – see system precision page.
- For standard accuracy this equates to around 20 microns for a metre length, increasing to 35 microns for a 4 metre length.

What lengths can be provided?

- We have standard rail lengths. These are based on the hole pitch of the rails and end machining to provide an equidistant length to the first and last hole centre.
- However we can cut the rail (from stock) to any length required – we just need to know the distance required to the first hole.
- In general our cutting procedures allow for a ± 2 mm accuracy on the overall rail length. If greater accuracy than this is required then we have to machine the end accurately (rather than cut it) and this involves extra time and cost.
- Standard maximum length for each rail size is around 4 metres. Rails can be joined together but the preparation needs to be made in our workshop. The rails will be marked clearly with the ends to be placed adjacent to each other.

Installation

- The linear guideways are very accurate and as a result need to be installed on accurately prepared surfaces – please see installation instructions. If the two rails are installed parallel to each other, they need to be accurately aligned – see assembly precision page.
- If you are not able to prepare the surface as accurately as required you might want to consider using our Compact Rail system, as this has a master rail (T rail) and a slave rail (U rail) that allows for structural inaccuracies.

Mounting the carriages to the rails

- In general the carriages will be supplied separately to the rails. To install the carriage onto the rails, offer the carriage up to the rails and slide it onto the rail itself.

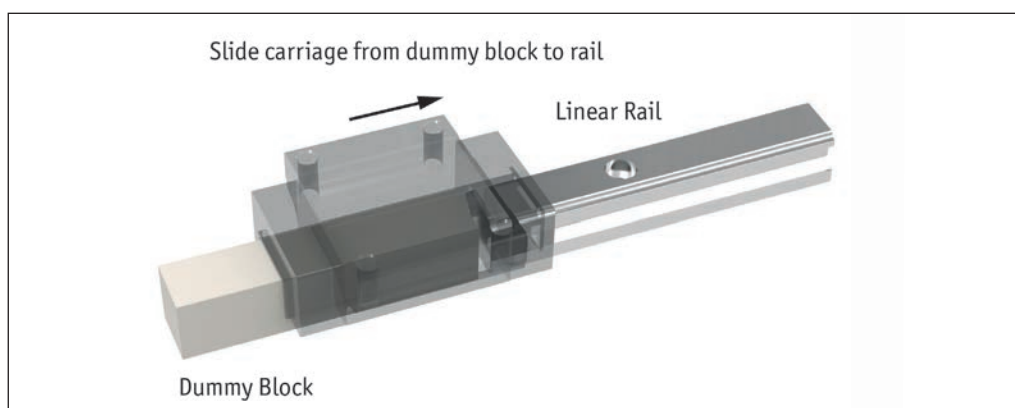



New ball chain technology

Our new and improved linear guideway systems include the latest “ball chain” technology with the following benefits:

- Higher maximum velocity.
- Lower heat generation
- Lower noise generation.
- Very smooth running.
- Optimised lubrication system
- Even load distribution
- Longer service life

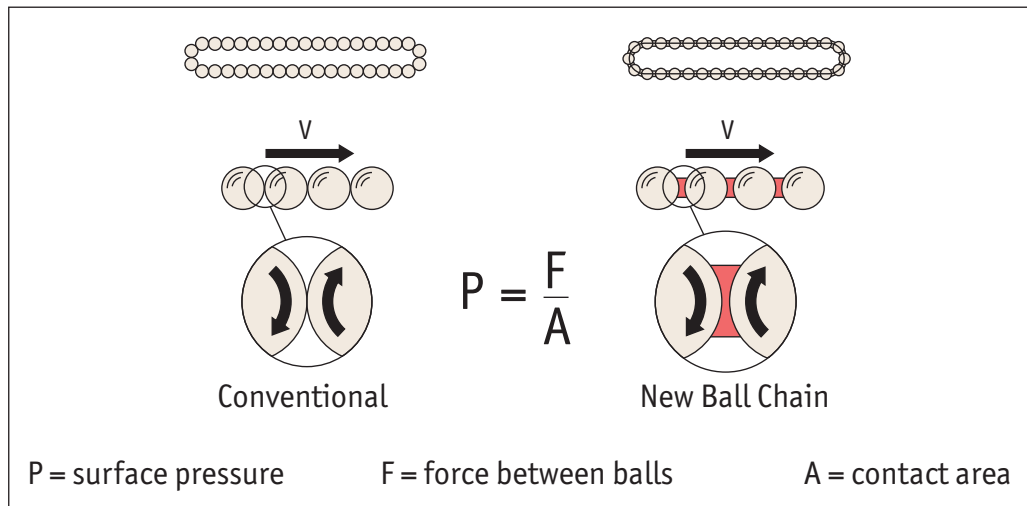

The rotating balls in conventional profile rail guides have point contact between each other. The rotation speed at the contact point is double the speed of the balls. The contact area (A) is so small that the surface pressure (P) tends towards infinity. This leads to heating and wear of the balls and the linear guide system.

The chain system in our new linear guides have a relatively large contact area (A), this significantly reduces the surface area pressure (P). The rotation speeds at the contact surfaces of ball and chain are the same. The ball chain is used to transport the lubricant and to create a lubrication film on the balls. The design of the carriage allows effective supply of lubricant from the lubricant connection to the circulation areas of the ball chains.

This design of the of the ball chain ends in connection with the spacer ball closes the circulation and makes the movement of the carriage smooth and quiet.

