

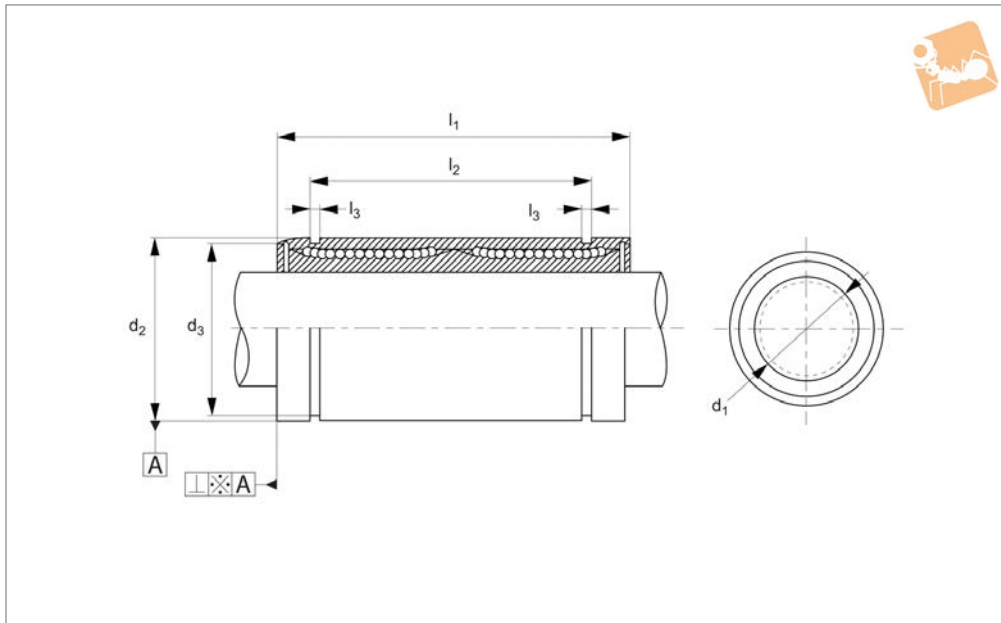

Stainless Ball Bushings

Long version

Linear Bearings



L1713

LINEAR BEARINGS

Material

Stainless steel body (440C) with either a resin (POM) or stainless steel (316) retainer.
Stainless steel balls (440C).

Supplied with nitrile rubber (NBR) end seals.

Technical Notes

For use with corrosion resistant hardened

shafts (see part no. L1772) - tolerance h6.
Perpendicularity A is better than 15μ.
Temperature range: For resin ball cage -20°C to +80°C.
For stainless ball cage -20°C to +120°C.

Order No.	Ball cage	d ₁ tol. h6	d ₂ tol. h6	l ₁	l ₂	l ₃	d ₃	Dyn. load C N max.	No. of ball circuits	Static load C ₀ N max.	Weight g
L1713.008-RS	Resin	8	16	45	33.0	1.10	15.2	430	4	780	31
L1713.012-RS	Resin	12	22	57	45.8	1.30	21.0	650	4	1200	80
L1713.016-RS	Resin	16	26	70	49.8	1.30	24.9	1230	5	2350	145
L1713.020-RS	Resin	20	32	80	61.0	1.60	30.3	1400	5	2750	180
L1713.025-RS	Resin	25	40	112	82.0	1.85	38.0	1560	6	3140	440
L1713.008-SS	Stainless	8	16	45	33.0	1.10	15.2	430	4	780	31
L1713.012-SS	Stainless	12	22	57	45.8	1.30	21.0	650	4	1200	80
L1713.016-SS	Stainless	16	26	70	49.8	1.30	24.9	1230	5	2350	145
L1713.020-SS	Stainless	20	32	80	61.0	1.60	30.3	1400	5	2750	180
L1713.025-SS	Stainless	25	40	112	82.0	1.85	38.0	1560	6	3140	440



Linear ball bushings

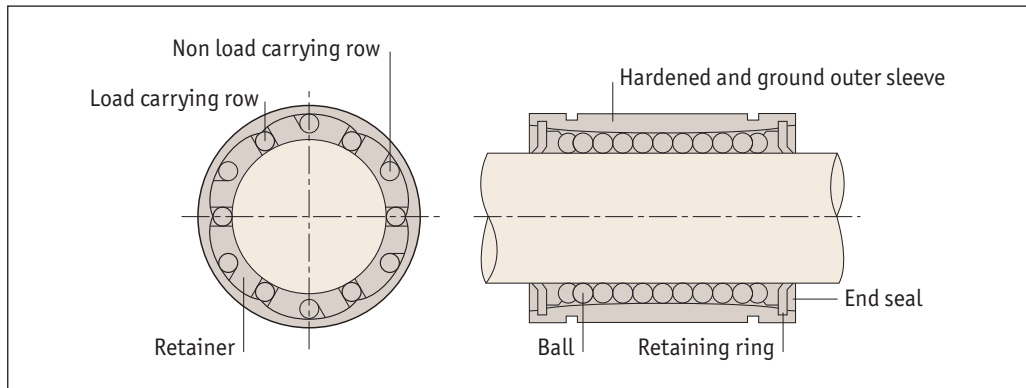

Applications

- Computers and peripheral equipment.
- Recording equipment.
- Linear motion systems.
- Multi-axis drilling machine.
- Printing machines.
- Food packaging machines.
- Punching presses.
- Tool grinders.
- Assembly systems.
- Card selectors.

Interchangeability

Our linear bushing systems are designed to have full interchangeability, with other manufacturers' parts. **For shafting see part numbers L1770 to L1785.**

High precision retainer

The single body retainer guides 4-6 ball circuits. It precisely guides the balls with a smooth motion.

Tolerance of housing bore

Normal fit is standard, pressed fit is for without clearance.

Type	Case	
	Normal fit	Pressed fit
Part no.		
L1706 to L1733	H7	K6, J6
L1706... ⁻¹ to L1733... ⁻¹	H7	J7

Rigid outer sleeve

The hardened and precisely ground outer sleeve is made of bearing steel.

L1750 bushing carriages

Consists of light aluminium case and L1706 type linear bushing, so the installation can be finished simply by bolting. Longer life can be obtained by adjusting the orientation of the ball circuits in the linear carriage element against the direction of load.

Tolerance of shaft

Type	Shaft	
	Normal fit	Tight fit
Part no.		
L1706 to L1733	h6	k6
L1706... ⁻¹ to L1733... ⁻¹	f6, g6	h6



Technical Information

Load rating important information



Basic dynamic load rating C

The basic dynamic load rating is defined as the constant load both in direction and magnitude under which a group of identical linear bushings are individually operated. 90% of the units can travel 50KM without failing due to rolling contact fatigue.

Basic static load rating C₀

If a linear bushing is subject to an excessive load or impact, a permanent deformation occurs between the raceway and the rolling element. The basic static load rating is defined as the static load that gives a prescribed constant contact stress at the centre of the contact area between the rolling element and raceway receiving the maximum load.

Relationships between load ratings and the position of ball circuits

Load ratings of linear bushing are affected by the position of the ball circuits as shown below.

Load ratings and orientation of balls.

No of ball rows	Orientation of balls	
	Maximum load rating	Minimum load rating
4		
	$F = 1.41 \times C$	$F = C$
5		
	$F = 1.46 \times C$	$F = C$
6		
	$F = 1.26 \times C$	$F = C$



When designing a linear motion system it is necessary to consider how the application will affect performance. The following examples demonstrate how the position of the load and the centre of gravity can influence product selection. When evaluating your application, review each of the forces acting on your system and determine the product that best suits your needs.

Horizontal application

For uniform speed or when stopped.

$$F_{1z} = \frac{W}{4} + \left(\frac{W}{2} \cdot \frac{d_2}{d_0} \right) - \left(\frac{W}{2} \cdot \frac{d_3}{d_1} \right)$$

$$F_{2z} = \frac{W}{4} - \left(\frac{W}{2} \cdot \frac{d_2}{d_0} \right) - \left(\frac{W}{2} \cdot \frac{d_3}{d_1} \right)$$

$$F_{3z} = \frac{W}{4} - \left(\frac{W}{2} \cdot \frac{d_2}{d_0} \right) + \left(\frac{W}{2} \cdot \frac{d_3}{d_1} \right)$$

$$F_{4z} = \frac{W}{4} + \left(\frac{W}{2} \cdot \frac{d_2}{d_0} \right) + \left(\frac{W}{2} \cdot \frac{d_3}{d_1} \right)$$

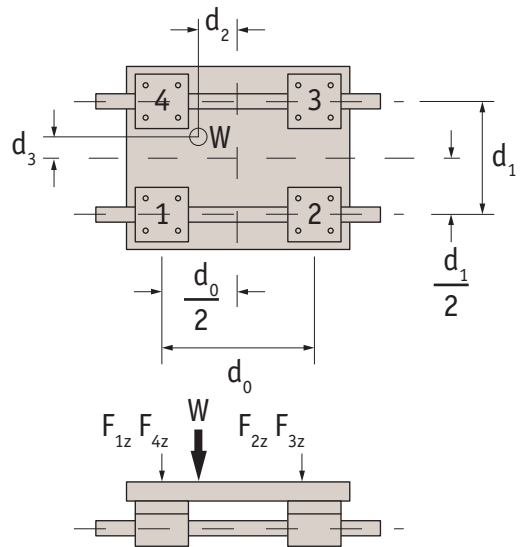

Horizontal application

For uniform speed or when stopped.

$$F_{1z} = \frac{W}{4} + \left(\frac{W}{2} \cdot \frac{d_2}{d_0} \right) - \left(\frac{W}{2} \cdot \frac{d_3}{d_1} \right)$$

$$F_{2z} = \frac{W}{4} - \left(\frac{W}{2} \cdot \frac{d_2}{d_0} \right) - \left(\frac{W}{2} \cdot \frac{d_3}{d_1} \right)$$

$$F_{3z} = \frac{W}{4} - \left(\frac{W}{2} \cdot \frac{d_2}{d_0} \right) + \left(\frac{W}{2} \cdot \frac{d_3}{d_1} \right)$$

$$F_{4z} = \frac{W}{4} + \left(\frac{W}{2} \cdot \frac{d_2}{d_0} \right) + \left(\frac{W}{2} \cdot \frac{d_3}{d_1} \right)$$

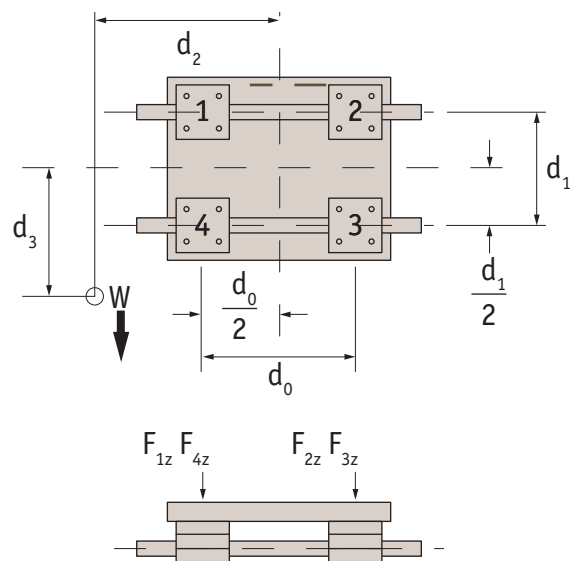



Side mounted application

For uniform speed or when stopped.

$$F_{1Y} \sim F_{4Y} = \left(\frac{W}{2} \cdot \frac{d_3}{d_0} \right)$$

$$F_{1Z} = F_{4Z} = \frac{W}{4} + \left(\frac{W}{2} \cdot \frac{d_2}{d_0} \right)$$

$$F_{2Z} = F_{3Z} = \frac{W}{4} + \left(\frac{W}{2} \cdot \frac{d_2}{d_0} \right)$$

Vertical application

For uniform speed or when stopped. On start up/stop the load varies due to inertia in the system.

$$F_{1X} \sim F_{4X} = \left(\frac{W}{2} \cdot \frac{d_2}{d_0} \right)$$

$$F_{1Y} \sim F_{4Y} = \left(\frac{W}{2} \cdot \frac{d_3}{d_0} \right)$$

$$F_{1X} + F_{4X} \sim F_{2X} + F_{3X}$$

$$F_{1Y} + F_{4Y} \sim F_{2Y} + F_{3Y}$$

ov-linear-ball-bushings-load-rating-c-rmh - Updated - 22-02-2023