

Socket Button Screws

Steel - zinc-plated

Standard Screws



P0210.ZP

STANDARD SCREWS

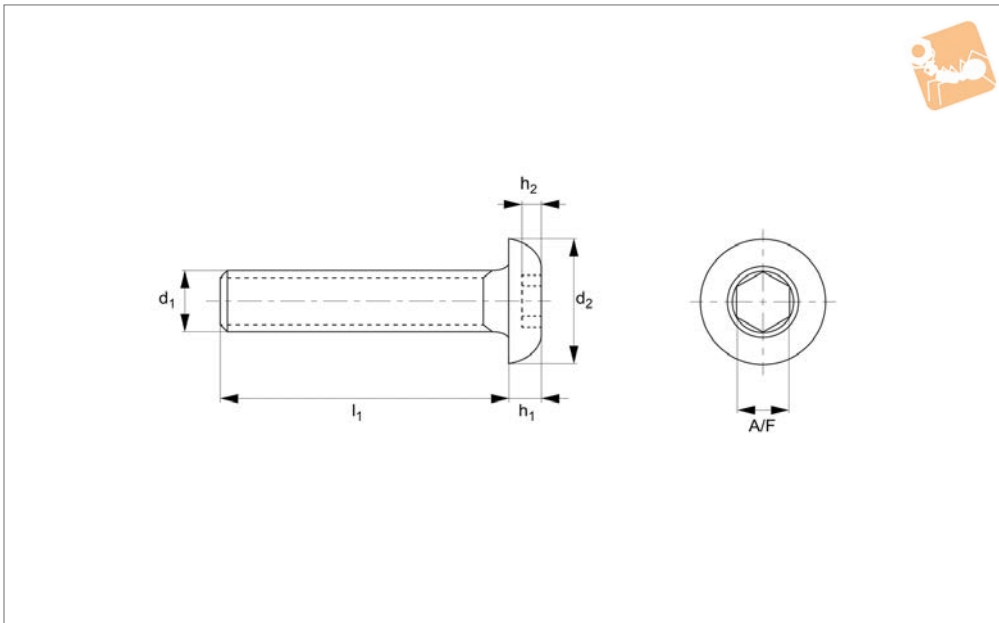

Material

Steel, zinc-plated (grade 10.9).

Technical Notes

To ISO 7380. Threaded within 2,5 x pitch of head.

Order No.	d ₁	l ₁	d ₂	h ₁	h ₂	A/F
P0210.030-004-ZP	M 3	4	5.7	1.65	1.04	2
P0210.030-005-ZP	M 3	5	5.7	1.65	1.04	2
P0210.030-006-ZP	M 3	6	5.7	1.65	1.04	2
P0210.030-008-ZP	M 3	8	5.7	1.65	1.04	2
P0210.030-010-ZP	M 3	10	5.7	1.65	1.04	2
P0210.030-012-ZP	M 3	12	5.7	1.65	1.04	2
P0210.030-016-ZP	M 3	16	5.7	1.65	1.04	2
P0210.030-020-ZP	M 3	20	5.7	1.65	1.04	2
P0210.030-025-ZP	M 3	25	5.7	1.65	1.04	2
P0210.030-030-ZP	M 3	30	5.7	1.65	1.04	2
P0210.030-035-ZP	M 3	35	5.7	1.65	1.04	2
P0210.030-040-ZP	M 3	40	5.7	1.65	1.04	2
P0210.040-005-ZP	M 4	5	7.6	2.2	1.3	2.5
P0210.040-006-ZP	M 4	6	7.6	2.2	1.3	2.5
P0210.040-008-ZP	M 4	8	7.6	2.2	1.3	2.5
P0210.040-010-ZP	M 4	10	7.6	2.2	1.3	2.5
P0210.040-012-ZP	M 4	12	7.6	2.2	1.3	2.5
P0210.040-014-ZP	M 4	14	7.6	2.2	1.3	2.5
P0210.040-016-ZP	M 4	16	7.6	2.2	1.3	2.5
P0210.040-020-ZP	M 4	20	7.6	2.2	1.3	2.5
P0210.040-025-ZP	M 4	25	7.6	2.2	1.3	2.5
P0210.040-030-ZP	M 4	30	7.6	2.2	1.3	2.5
P0210.040-035-ZP	M 4	35	7.6	2.2	1.3	2.5
P0210.040-040-ZP	M 4	40	7.6	2.2	1.3	2.5
P0210.040-045-ZP	M 4	45	7.6	2.2	1.3	2.5
P0210.040-050-ZP	M 4	40	7.6	2.2	1.3	2.5
P0210.050-006-ZP	M 5	6	9.5	2.75	1.56	3
P0210.050-008-ZP	M 5	8	9.5	2.75	1.56	3
P0210.050-010-ZP	M 5	10	9.5	2.75	1.56	3
P0210.050-012-ZP	M 5	12	9.5	2.75	1.56	3
P0210.050-014-ZP	M 5	14	9.5	2.75	1.56	3
P0210.050-016-ZP	M 5	16	9.5	2.75	1.56	3
P0210.050-020-ZP	M 5	20	9.5	2.75	1.56	3
P0210.050-025-ZP	M 5	25	9.5	2.75	1.56	3
P0210.050-030-ZP	M 5	30	9.5	2.75	1.56	3



STANDARD SCREWS

Order No.	d ₁	l ₁	d ₂	h ₁	h ₂	A/F
P0210.050-035-ZP	M 5	35	9.5	2.75	1.56	3
P0210.050-040-ZP	M 5	40	9.5	2.75	1.56	3
P0210.050-045-ZP	M 5	45	9.5	2.75	1.56	3
P0210.050-050-ZP	M 5	50	9.5	2.75	1.56	3
P0210.050-055-ZP	M 5	55	9.5	2.75	1.56	3
P0210.050-060-ZP	M 5	60	9.5	2.75	1.56	3
P0210.060-008-ZP	M 6	8	10.5	3.3	2.08	4
P0210.060-010-ZP	M 6	10	10.5	3.3	2.08	4
P0210.060-012-ZP	M 6	12	10.5	3.3	2.08	4
P0210.060-014-ZP	M 6	14	10.5	3.3	2.08	4
P0210.060-016-ZP	M 6	16	10.5	3.3	2.08	4
P0210.060-020-ZP	M 6	20	10.5	3.3	2.08	4
P0210.060-025-ZP	M 6	25	10.5	3.3	2.08	4
P0210.060-030-ZP	M 6	30	10.5	3.3	2.08	4
P0210.060-035-ZP	M 6	35	10.5	3.3	2.08	4
P0210.060-040-ZP	M 6	40	10.5	3.3	2.08	4
P0210.060-045-ZP	M 6	45	10.5	3.3	2.08	4
P0210.060-050-ZP	M 6	50	10.5	3.3	2.08	4
P0210.060-055-ZP	M 6	55	10.5	3.3	2.08	4
P0210.060-060-ZP	M 6	60	10.5	3.3	2.08	4
P0210.060-070-ZP	M 6	70	10.5	3.3	2.08	4
P0210.080-010-ZP	M 8	10	14	4.4	2.6	5
P0210.080-012-ZP	M 8	12	14	4.4	2.6	5
P0210.080-014-ZP	M 8	14	14	4.4	2.6	5
P0210.080-016-ZP	M 8	16	14	4.4	2.6	5
P0210.080-020-ZP	M 8	20	14	4.4	2.6	5
P0210.080-025-ZP	M 8	25	14	4.4	2.6	5
P0210.080-030-ZP	M 8	30	14	4.4	2.6	5
P0210.080-035-ZP	M 8	35	14	4.4	2.6	5
P0210.080-040-ZP	M 8	40	14	4.4	2.6	5
P0210.080-045-ZP	M 8	45	14	4.4	2.6	5
P0210.080-050-ZP	M 8	50	14	4.4	2.6	5
P0210.080-055-ZP	M 8	55	14	4.4	2.6	5
P0210.080-060-ZP	M 8	60	14	4.4	2.6	5
P0210.080-070-ZP	M 8	70	14	4.4	2.6	5
P0210.080-080-ZP	M 8	80	14	4.4	2.6	5
P0210.100-012-ZP	M10	12	17.5	5.5	3.12	6
P0210.100-016-ZP	M10	16	17.5	5.5	3.12	6
P0210.100-020-ZP	M10	20	17.5	5.5	3.12	6
P0210.100-025-ZP	M10	25	17.5	5.5	3.12	6
P0210.100-030-ZP	M10	30	17.5	5.5	3.12	6
P0210.100-035-ZP	M10	35	17.5	5.5	3.12	6
P0210.100-040-ZP	M10	40	17.5	5.5	3.12	6
P0210.100-045-ZP	M10	45	17.5	5.5	3.12	6
P0210.100-050-ZP	M10	50	17.5	5.5	3.12	6
P0210.100-055-ZP	M10	55	17.5	5.5	3.12	6
P0210.100-060-ZP	M10	60	17.5	5.5	3.12	6
P0210.100-070-ZP	M10	70	17.5	5.5	3.12	6
P0210.100-080-ZP	M10	80	17.5	5.5	3.12	6
P0210.120-020-ZP	M12	20	21	6.6	4.16	8
P0210.120-025-ZP	M12	25	21	6.6	4.16	8
P0210.120-030-ZP	M12	30	21	6.6	4.16	8
P0210.120-035-ZP	M12	35	21	6.6	4.16	8
P0210.120-040-ZP	M12	40	21	6.6	4.16	8
P0210.120-045-ZP	M12	45	21	6.6	4.16	8
P0210.120-050-ZP	M12	50	21	6.6	4.16	8
P0210.120-055-ZP	M12	55	21	6.6	4.16	8
P0210.120-060-ZP	M12	60	21	6.6	4.16	8
P0210.120-070-ZP	M12	70	21	6.6	4.16	8
P0210.120-080-ZP	M12	80	21	6.6	4.16	8