

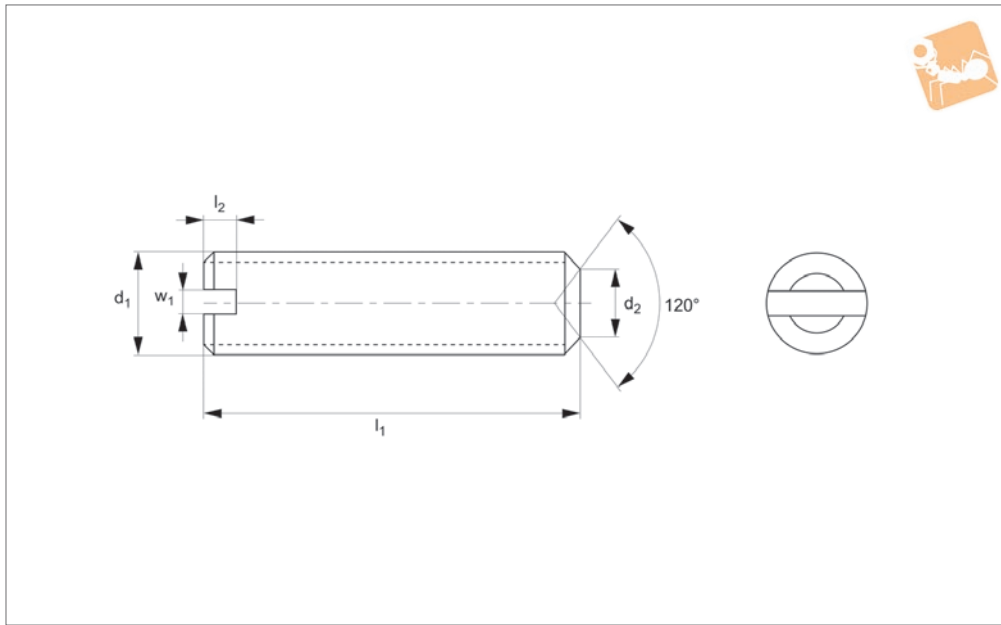

Slotted Set Screws Cup Point

Cup Point - steel, zinc-plated

Standard Screws



P0276.ZP

STANDARD SCREWS

Material

Steel, zinc-plated (class 14H).

Technical Notes

To DIN 438, cup point.

Order No.	d ₁	l ₁	d ₂	l ₂ min.	w ₁
P0276.020-003-ZP	M 2	3	0.75	0.8	0.25
P0276.020-004-ZP	M 2	4	0.75	0.8	0.25
P0276.020-005-ZP	M 2	5	0.75	0.8	0.25
P0276.020-006-ZP	M 2	6	0.75	0.8	0.25
P0276.020-008-ZP	M 2	8	0.75	0.8	0.25
P0276.020-010-ZP	M 2	10	0.75	0.8	0.25
P0276.020-012-ZP	M 2	12	0.75	0.8	0.25
P0276.020-016-ZP	M 2	16	0.75	0.8	0.25
P0276.025-003-ZP	M2,5	3	0.95	1.2	0.4
P0276.025-004-ZP	M2,5	4	0.95	1.2	0.4
P0276.025-005-ZP	M2,5	5	0.95	1.2	0.4
P0276.025-006-ZP	M2,5	6	0.95	1.2	0.4
P0276.025-008-ZP	M2,5	8	0.95	1.2	0.4
P0276.025-010-ZP	M2,5	10	0.95	1.2	0.4
P0276.025-012-ZP	M2,5	12	0.95	1.2	0.4
P0276.025-016-ZP	M2,5	16	0.95	1.2	0.4
P0276.030-003-ZP	M 3	3	1.15	1.2	0.4
P0276.030-004-ZP	M 3	4	1.15	1.2	0.4
P0276.030-005-ZP	M 3	5	1.15	1.2	0.4
P0276.030-006-ZP	M 3	6	1.15	1.2	0.4
P0276.030-008-ZP	M 3	8	1.15	1.2	0.4
P0276.030-010-ZP	M 3	10	1.15	1.2	0.4
P0276.030-012-ZP	M 3	12	1.15	1.2	0.4
P0276.030-014-ZP	M 3	14	1.15	1.2	0.4
P0276.030-016-ZP	M 3	16	1.15	1.2	0.4
P0276.030-020-ZP	M 3	20	1.15	1.2	0.4
P0276.030-025-ZP	M 3	25	1.15	1.2	0.4
P0276.030-030-ZP	M 3	30	1.15	1.2	0.4
P0276.040-003-ZP	M 4	3	1.75	1.5	0.6
P0276.040-004-ZP	M 4	4	1.75	1.5	0.6
P0276.040-005-ZP	M 4	5	1.75	1.5	0.6
P0276.040-006-ZP	M 4	6	1.75	1.5	0.6
P0276.040-008-ZP	M 4	8	1.75	1.5	0.6
P0276.040-010-ZP	M 4	10	1.75	1.5	0.6



Order No.	d ₁	l ₁	d ₂	l ₂ min.	w ₁
P0276.040-012-ZP	M 4	12	1.75	1.5	0.6
P0276.040-014-ZP	M 4	14	1.75	1.5	0.6
P0276.040-016-ZP	M 4	16	1.75	1.5	0.6
P0276.040-020-ZP	M 4	20	1.75	1.5	0.6
P0276.040-025-ZP	M 4	25	1.75	1.5	0.6
P0276.040-030-ZP	M 4	30	1.75	1.5	0.6
P0276.040-035-ZP	M 4	35	1.75	1.5	0.6
P0276.040-040-ZP	M 4	40	1.75	1.5	0.6
P0276.050-004-ZP	M 5	4	2.25	2.0	0.8
P0276.050-005-ZP	M 5	5	2.25	2.0	0.8
P0276.050-006-ZP	M 5	6	2.25	2.0	0.8
P0276.050-008-ZP	M 5	8	2.25	2.0	0.8
P0276.050-010-ZP	M 5	10	2.25	2.0	0.8
P0276.050-012-ZP	M 5	12	2.25	2.0	0.8
P0276.050-014-ZP	M 5	14	2.25	2.0	0.8
P0276.050-016-ZP	M 5	16	2.25	2.0	0.8
P0276.050-020-ZP	M 5	20	2.25	2.0	0.8
P0276.050-025-ZP	M 5	25	2.25	2.0	0.8
P0276.050-030-ZP	M 5	30	2.25	2.0	0.8
P0276.050-035-ZP	M 5	35	2.25	2.0	0.8
P0276.050-040-ZP	M 5	40	2.25	2.0	0.8
P0276.060-005-ZP	M 6	5	2.75	2.0	1.0
P0276.060-006-ZP	M 6	6	2.75	2.0	1.0
P0276.060-008-ZP	M 6	8	2.75	2.0	1.0
P0276.060-010-ZP	M 6	10	2.75	2.0	1.0
P0276.060-012-ZP	M 6	12	2.75	2.0	1.0
P0276.060-014-ZP	M 6	14	2.75	2.0	1.0
P0276.060-016-ZP	M 6	16	2.75	2.0	1.0
P0276.060-018-ZP	M 6	18	2.75	2.0	1.0
P0276.060-020-ZP	M 6	20	2.75	2.0	1.0
P0276.060-025-ZP	M 6	25	2.75	2.0	1.0
P0276.060-030-ZP	M 6	30	2.75	2.0	1.0
P0276.060-035-ZP	M 6	35	2.75	2.0	1.0
P0276.060-040-ZP	M 6	40	2.75	2.0	1.0
P0276.060-045-ZP	M 6	45	2.75	2.0	1.0
P0276.060-050-ZP	M 6	50	2.75	2.0	1.0
P0276.060-055-ZP	M 6	55	2.75	2.0	1.0
P0276.060-060-ZP	M 6	60	2.75	2.0	1.0
P0276.080-006-ZP	M 8	6	4.70	3.0	1.2
P0276.080-008-ZP	M 8	8	4.70	3.0	1.2
P0276.080-010-ZP	M 8	10	4.70	3.0	1.2
P0276.080-012-ZP	M 8	12	4.70	3.0	1.2
P0276.080-014-ZP	M 8	14	4.70	3.0	1.2
P0276.080-016-ZP	M 8	16	4.70	3.0	1.2
P0276.080-018-ZP	M 8	18	4.70	3.0	1.2
P0276.080-020-ZP	M 8	20	4.70	3.0	1.2
P0276.080-025-ZP	M 8	25	4.70	3.0	1.2
P0276.080-030-ZP	M 8	30	4.70	3.0	1.2
P0276.080-035-ZP	M 8	35	4.70	3.0	1.2
P0276.080-040-ZP	M 8	40	4.70	3.0	1.2
P0276.080-050-ZP	M 8	50	4.70	3.0	1.2
P0276.080-060-ZP	M 8	60	4.70	3.0	1.2
P0276.080-070-ZP	M 8	70	4.70	3.0	1.2
P0276.080-080-ZP	M 8	80	4.70	3.0	1.2
P0276.100-010-ZP	M10	10	5.70	4.0	1.6
P0276.100-012-ZP	M10	12	5.70	4.0	1.6
P0276.100-016-ZP	M10	16	5.70	4.0	1.6
P0276.100-020-ZP	M10	20	5.70	4.0	1.6
P0276.100-025-ZP	M10	25	5.70	4.0	1.6
P0276.100-030-ZP	M10	30	5.70	4.0	1.6
P0276.100-035-ZP	M10	35	5.70	4.0	1.6
P0276.100-040-ZP	M10	40	5.70	4.0	1.6
P0276.100-045-ZP	M10	45	5.70	4.0	1.6
P0276.100-050-ZP	M10	50	5.70	4.0	1.6
P0276.100-055-ZP	M10	55	5.70	4.0	1.6
P0276.100-060-ZP	M10	60	5.70	4.0	1.6
P0276.100-070-ZP	M10	70	5.70	4.0	1.6
P0276.100-080-ZP	M10	80	5.70	4.0	1.6



Slotted Set Screws Cup Point

Cup Point - steel, zinc-plated

Standard Screws



Order No.	d ₁	l ₁	d ₂	l ₂ min.	w ₁
P0276.120-010-ZP	M12	12	7.64	4.8	2.0
P0276.120-012-ZP	M12	12	7.64	4.8	2.0
P0276.120-016-ZP	M12	16	7.64	4.8	2.0
P0276.120-020-ZP	M12	20	7.64	4.8	2.0
P0276.120-025-ZP	M12	25	7.64	4.8	2.0
P0276.120-030-ZP	M12	30	7.64	4.8	2.0
P0276.120-035-ZP	M12	35	7.64	4.8	2.0
P0276.120-040-ZP	M12	40	7.64	4.8	2.0
P0276.120-045-ZP	M12	45	7.64	4.8	2.0
P0276.120-050-ZP	M12	50	7.64	4.8	2.0
P0276.120-055-ZP	M12	55	7.64	4.8	2.0
P0276.120-060-ZP	M12	60	7.64	4.8	2.0
P0276.120-070-ZP	M12	70	7.64	4.8	2.0
P0276.120-080-ZP	M12	80	7.64	4.8	2.0
P0276.120-090-ZP	M12	90	7.64	4.8	2.0
P0276.120-100-ZP	M12	100	7.64	4.8	2.0
P0276.160-016-ZP	M16	16	9.64	6.4	2.2
P0276.160-020-ZP	M16	20	9.64	6.4	2.2
P0276.160-025-ZP	M16	25	9.64	6.4	2.2
P0276.160-030-ZP	M16	30	9.64	6.4	2.2
P0276.160-035-ZP	M16	35	9.64	6.4	2.2
P0276.160-040-ZP	M16	40	9.64	6.4	2.2
P0276.160-045-ZP	M16	45	9.64	6.4	2.2
P0276.160-050-ZP	M16	50	9.64	6.4	2.2
P0276.160-055-ZP	M16	55	9.64	6.4	2.2
P0276.160-060-ZP	M16	60	9.64	6.4	2.2
P0276.160-070-ZP	M16	70	9.64	6.4	2.2
P0276.160-080-ZP	M16	80	9.64	6.4	2.2
P0276.160-090-ZP	M16	90	9.64	6.4	2.2
P0276.160-100-ZP	M16	100	9.64	6.4	2.2
P0276.200-020-ZP	M20	20	13.57	8.0	2.6
P0276.200-025-ZP	M20	25	13.57	8.0	2.6
P0276.200-030-ZP	M20	30	13.57	8.0	2.6
P0276.200-035-ZP	M20	35	13.57	8.0	2.6
P0276.200-040-ZP	M20	40	13.57	8.0	2.6
P0276.200-045-ZP	M20	45	13.57	8.0	2.6
P0276.200-050-ZP	M20	50	13.57	8.0	2.6
P0276.200-055-ZP	M20	55	13.57	8.0	2.6
P0276.200-060-ZP	M20	60	13.57	8.0	2.6
P0276.200-070-ZP	M20	70	13.57	8.0	2.6
P0276.200-080-ZP	M20	80	13.57	8.0	2.6
P0276.200-090-ZP	M20	90	13.57	8.0	2.6
P0276.200-100-ZP	M20	100	13.57	8.0	2.6

STANDARD SCREWS