

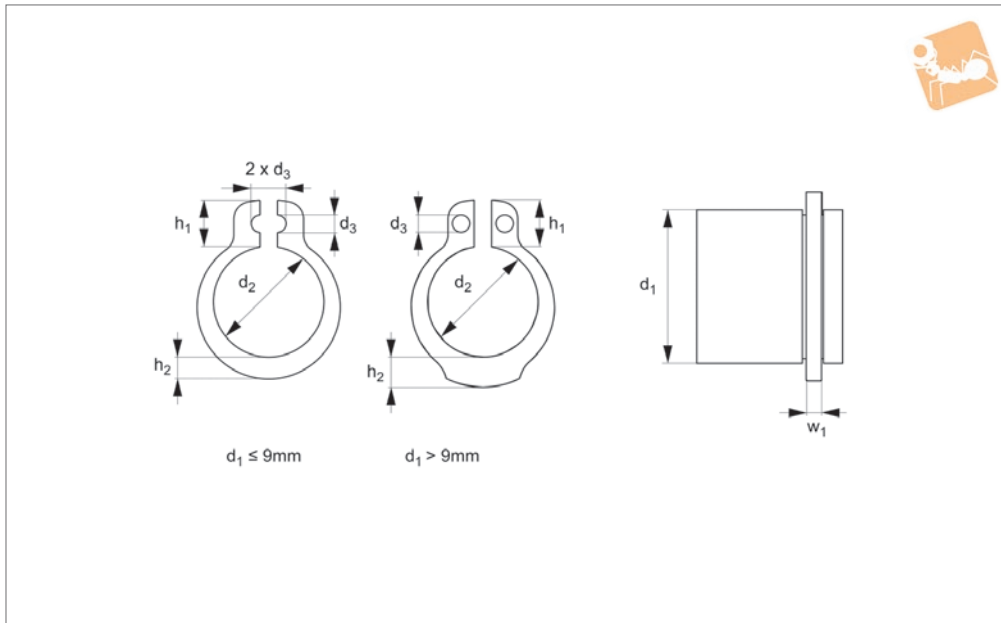

External A2 Circlips

A2 stainless

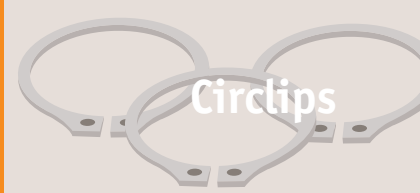

P0380.A2

CIRCLIPS

Material

Stainless steel (A2, AISI 303).

Technical Notes

To DIN 471.

Order No.	d ₁	d ₂	d ₃ min.	h ₁ max.	h ₂	w ₁	Material
P0380.003-A2	3	2.7	1.0	1.9	0.8	0.40	A2 s/s
P0380.004-A2	4	3.7	1.0	2.2	0.9	0.40	A2 s/s
P0380.005-A2	5	3.7	1.0	2.5	1.1	0.60	A2 s/s
P0380.006-A2	6	5.6	1.2	2.7	1.3	0.70	A2 s/s
P0380.007-A2	7	6.5	1.2	3.1	1.4	0.80	A2 s/s
P0380.008-A2	8	7.4	1.2	3.2	1.5	0.80	A2 s/s
P0380.009-A2	9	8.4	1.2	3.3	1.7	1.00	A2 s/s
P0380.010-A2	10	9.3	1.5	3.3	1.8	1.00	A2 s/s
P0380.011-A2	11	10.2	1.5	3.3	1.8	1.00	A2 s/s
P0380.012-A2	12	11.0	1.7	3.3	1.8	1.00	A2 s/s
P0380.013-A2	13	11.9	1.7	3.4	2.0	1.00	A2 s/s
P0380.014-A2	14	12.9	1.7	3.5	2.1	1.00	A2 s/s
P0380.015-A2	15	13.8	1.7	3.6	0.8	1.00	A2 s/s
P0380.016-A2	16	14.7	1.7	3.7	2.2	1.00	A2 s/s
P0380.017-A2	17	15.7	1.7	3.8	2.3	1.00	A2 s/s
P0380.018-A2	18	16.5	2.0	3.9	2.4	1.20	A2 s/s
P0380.019-A2	19	17.5	2.0	3.9	2.5	1.20	A2 s/s
P0380.020-A2	20	18.5	2.0	4.0	2.6	1.20	A2 s/s
P0380.022-A2	22	20.5	2.0	4.2	2.8	1.20	A2 s/s
P0380.023-A2	23	21.4	2.0	4.3	2.9	1.20	A2 s/s
P0380.024-A2	24	22.2	2.0	4.4	3.0	1.20	A2 s/s
P0380.025-A2	25	23.2	2.0	4.4	3.0	1.20	A2 s/s
P0380.026-A2	26	24.2	2.0	4.5	3.1	1.20	A2 s/s
P0380.027-A2	27	25.1	2.0	4.6	3.1	1.20	A2 s/s
P0380.028-A2	28	25.9	2.0	4.7	3.2	1.50	A2 s/s
P0380.029-A2	29	26.9	2.0	4.8	3.4	1.50	A2 s/s
P0380.030-A2	30	27.9	2.0	5.0	3.5	1.50	A2 s/s
P0380.032-A2	32	29.6	2.5	5.2	3.6	1.50	A2 s/s
P0380.034-A2	34	31.5	2.5	5.4	3.8	1.50	A2 s/s
P0380.035-A2	35	32.2	2.5	5.6	3.9	1.50	A2 s/s
P0380.036-A2	36	33.2	2.5	5.6	4.0	1.75	A2 s/s
P0380.038-A2	38	35.2	2.5	5.8	4.2	1.75	A2 s/s
P0380.039-A2	39	36.0	2.5	5.9	4.3	1.75	A2 s/s
P0380.040-A2	40	36.0	2.5	6.0	4.4	1.75	A2 s/s

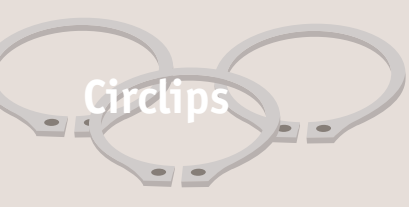

Circlips

External A2 Circlips A2 stainless



CIRCLIPS

Order No.	d ₁	d ₂	d ₃ min.	h ₁ max.	h ₂	w ₁	Material
P0380.042-A2	42	36.5	2.5	6.5	4.5	1.75	A2 s/s
P0380.045-A2	45	41.5	2.5	6.7	4.7	1.75	A2 s/s
P0380.048-A2	48	44.5	2.5	6.9	5.0	1.75	A2 s/s
P0380.050-A2	50	45.8	2.5	6.9	5.1	2.00	A2 s/s
P0380.052-A2	52	47.8	2.5	7.0	5.2	2.00	A2 s/s
P0380.055-A2	55	50.8	2.5	7.2	5.4	2.00	A2 s/s
P0380.060-A2	60	55.8	2.5	7.4	5.8	2.00	A2 s/s
P0380.065-A2	65	60.8	3.0	7.8	6.3	2.50	A2 s/s
P0380.070-A2	70	65.5	3.0	8.1	6.6	2.50	A2 s/s
P0380.075-A2	75	70.5	3.0	8.4	7.0	2.50	A2 s/s
P0380.080-A2	80	74.5	3.0	8.6	7.4	2.50	A2 s/s
P0380.085-A2	85	79.5	3.5	8.7	7.8	3.00	A2 s/s
P0380.090-A2	90	84.5	3.5	8.8	8.2	3.00	A2 s/s
P0380.095-A2	95	89.5	3.5	9.4	8.6	3.00	A2 s/s
P0380.100-A2	100	94.5	3.5	9.6	9.0	3.00	A2 s/s
P0380.105-A2	105	98.0	3.5	9.9	9.3	4.00	A2 s/s
P0380.110-A2	110	103.0	3.5	10.1	9.6	4.00	A2 s/s
P0380.120-A2	120	113.0	3.5	11.0	10.2	4.00	A2 s/s
P0380.130-A2	130	123.0	4.0	11.6	10.7	4.00	A2 s/s
P0380.140-A2	140	133.0	4.0	12.0	11.2	4.00	A2 s/s